



Monroe Municipal Utilities Authority  
**RATES, RULES AND REGULATIONS**

Applicable to sewerage and water service  
in the  
Township of Monroe, County of Gloucester  
State of New Jersey

Revised May 15, 2024

**MONROE MUNICIPAL UTILITIES AUTHORITY  
RATES, RULES AND REGULATIONS**

**TABLE OF CONTENTS**

SECTION 1	DEFINITIONS	PAGE 1
SECTION 2	DOMESTIC SERVICE	PAGE 7
2.1	Service to New Customers Through Existing Connections	
2.2	Landlord – Tenant Responsibility	
2.3	Discontinuation of Customer Service	
2.4	Tampering with the Meter	
SECTION 3	PUBLIC FIRE SERVICE	PAGE 9
3.1	Hydrant Locations	
3.2	Maintenance	
3.3	Allowable Uses	
3.4	Change of Location	
3.5	Inspection	
3.6	Notification	
3.7	Additional Valves	
SECTION 4	PRIVATE FIRE SERVICE	PAGE 11
4.1	Automatic Devices and Hydrants	
4.2	Ownership and Location	
4.3	Private Un-metered Fire Service	
4.4	Bills Rendered and Due	
SECTION 5	USE OF WATER FOR BUILDING PURPOSES	PAGE 12
	Special Application	
SECTION 6	WATER AND/OR SEWER APPLICATION – GENERAL	PAGE 13
6.1	General Provisions	
6.2	Applications – General	
6.3	Feasibility – Form A	
6.4	Preliminary Approval – Form B	
6.5	Construction Approval – Form C	
6.6	Acceptance of Project – Form D	
6.7	Connection into Existing Authority System – Form E-A	
6.8	Availability	
6.9	Change in Use	
SECTION 7	WATER AND/OR SEWER APPLICATION – COMMERCIAL & INDUSTRIAL	PAGE 29
7.1	Agreement Required	
7.2	Application for Construction Approval for Commercial or Industrial Applicants – Form B & E-A	
7.3	Prohibited Wastes	

<b>SECTION 7</b>	<b>WATER AND/OR SEWER APPLICATION – COMMERCIAL &amp; INDUSTRIAL</b>
7.4	Grease, Oil and Sand Separators
7.5	Pre-treatment
7.6	Control Manhole
7.7	Penalty for Violations and Discontinuance
7.8	Industrial Waste Flow Meter and Sampler
7.9	Industrial Connection Charge
7.10	Industrial Service Revisions

<b>SECTION 8</b>	<b>CONNECTIONS AND SERVICE LINES - WATER</b>	<b>PAGE 40</b>
8.1	Authority Service Line	
8.2	Size and Kind of Service Line	
8.3	Separate Trench	
8.4	Maintenance by Customer	
8.5	Authority Not Responsible	
8.6	Renewal of Service Lines	
8.7	Property Supplied by Single Service Line	
8.8	Single Service Line with Two or More Customers	
8.9	Sprinkling Systems	
8.10	Discontinuation of Water Service	
8.11	Connection Permit and Water Service Charges	
8.12	Access to Customer Facilities	

<b>SECTION 9</b>	<b>CONNECTIONS AND SERVICE LINES - SEWER</b>	<b>PAGE 44</b>
9.1	Authority Service Line	
9.2	Size and Kind of Lateral	
9.3	Service Lateral Replacement	
9.4	Elevation of Sanitary Fixtures	
9.5	Maintenance by Customer	
9.6	Responsibility of Authority	
9.7	Renewal of Service Lateral	
9.8	Prohibited Connections	
9.9	Special Connections	
9.10	Special Precautions in Wet Ground	
9.11	Property Serviced by a Single Service Lateral	
9.12	Single Service Lateral with Two or More Customers	
9.13	Policy on Blockages	
9.14	Policy on Missing or Damaged Curb Cleanout Caps	
9.15	Unauthorized Connection	
9.16	Construction Safeguards	
9.17	Discontinuation of Sewer Service	
9.18	Policy on New Authority Pump Stations	

<b>SECTION 10</b>	<b>WATER METERS</b>	<b>PAGE 49</b>
10.1	All Water Services Shall be Metered	
10.2	Service Fee	
10.3	Location	
10.4	Metering Box	
10.5	Valves Required	
10.6	Responsibility for Damage	
10.7	Cost of Reinstallation	
10.8	Minimum Charge	

SECTION 10	WATER METERS	
10.9	Authority to be Notified when Meter Not Working	
10.10	Registration Conclusive	
10.11	Disputed Account	
10.12	Request Test	
10.13	Turn Off Without Authority	
10.14	Tampering with Water Meter	
SECTION 11	DAMAGE TO SYSTEM	PAGE 52
11.1	Penalty	
SECTION 12	MINIMUM TECHNICAL DESIGN STANDARDS - SEWERAGE	PAGE 53
12.1	Separate Sewers Required	
12.2	Summary of Information Required	
12.3	Preparation of Sewer Maps and Plans	
12.4	Profiles	
12.5	Standard Details of Construction	
12.6	Specifications	
12.7	The Engineer's Report	
12.8	Capacity and Design Period	
12.9	Materials, Minimum Grades and Velocity of Flow	
12.10	Joints	
12.11	Manholes	
12.12	Pumping Stations	
12.13	Easements	
12.14	Electrical Service General	
SECTION 13	MINIMUM TECHNICAL DESIGN STANDARDS - WATER	PAGE 79
13.1	Preliminary Plans	
13.2	Applications for Approval	
13.3	Engineering Data to be submitted to the Department of Environmental Protection	
13.4	Engineer's Report	
13.5	Maps	
13.6	Plans	
13.7	Specifications	
13.8	Ground Water Supplies	
13.9	Distribution Systems	
13.10	Distribution Storage	
SECTION 14	RELATED TECHNICAL STANDARDS – SEWER	PAGE 90
14.1	Materials	
14.2	Ductile Iron Pipe	
14.3	Polyvinyl Chloride Pipe	
14.4	Manholes	
SECTION 15	RELATED TECHNICAL STANDARDS – WATER	PAGE 94
15.1	Water Mains	
15.2	Ductile Iron Pipe and Fittings	

SECTION 15	RELATED TECHNICAL STANDARDS - WATER	
15.3	Gate Valves	
15.4	Valve Boxes	
15.5	House Connections	
15.6	Fire Hydrants	
SECTION 16	RELATED TECHNICAL STANDARDS - GENERAL	PAGE 97
16.1	Cement	
16.2	Aggregates	
16.3	Water	
16.4	Concrete	
16.5	Reinforcement Steel	
16.6	Wire Mesh of Fabric	
16.7	Concrete Block	
16.8	Brick	
16.9	Mortar	
16.10	Iron Castings	
16.11	Ladder Rungs	
16.12	Excavation and Earthwork	
16.13	Pipe Laying and Installation	
SECTION 17	INSPECTION AND TESTING OF INSTALLED FACILITIES	PAGE 103
17.1	Inspection of Sewage and/or Water Distribution System During Course of Construction	
17.2	Testing of Completed System	
17.3	Bacteria Test	
SECTION 18	BILLING, PAYMENTS, DELINQUENCIES, ETC.	PAGE 106
18.1	Rendering of Bills for Water and Sewer Service	
18.2	Payment Schedule	
18.3	Delinquent Accounts	
18.4	Discontinuation of Service	
18.5	Renewal Service	
18.6	Abatement	
18.7	Continuing Obligation to Pay Service Charge	
SECTION 19	RESERVE SUPPLY	PAGE 109
	Reserve Water Storage	
SECTION 20	RESPONSIBILITY FOR SERVICE	PAGE 110
20.1	Complaints	
20.2	Reasonable Access	
20.3	No Oral Agreements	
20.4	Single Service – Water Only	
20.5	Single Service – Sewerage Only	
20.6	Emergency	
20.7	Discharges	
20.8	Mandatory Water and Sewer Connection	
20.9	Emergency Water Use Restrictions	

SECTION 21	SCHEDULE OF RATES	PAGE 117
21.1	Sewer Service Charges – Schedule 1	
21.2	Water Service Charges – Schedule 2	
21.3	Definition of Classes of Water/Sewer Service	
21.4	Connection Fees Water and/or Sewer – Schedule 3	
21.5	Miscellaneous Charges – Schedule 4	
21.6	Fire Service – Schedule 5	
21.7	Monroe MUA Wet Tap Price List	
21.8	Violations/Fines/Penalties	

SECTION 22	STANDARD DETAILS	PAGE 129
------------	------------------	----------

APPENDIX A	INSPECTION AND TESTING PROCEDURES MANUAL	PAGE 180
------------	--	----------

APPENDIX B	SAMPLE FORMS	PAGE 193
------------	--------------	----------

- Form A Application
- Sample Escrow Agreement
- Form B Application
- Form C Application
- Purchase Water and/or Sewer Permits
- Sample Performance Bond/Letter of Credit (Performance)
- Form C-2 Application
- Form D Application
- Sample Maintenance Bond/Letter of Credit (Maintenance)
- Form E-A Application
- Form E-D Application
- Form E-D Exempt Application

## SECTION 1 – INTRODUCTION AND DEFINITIONS & REFERENCED STANDARDS

### **1.A. Purpose**

The purpose of the Authority is to implement the Municipal Utilities Authority Law, N.J. Laws of L. 1957, c. 183, s. 1, c. 40:14B-2 et seq. 1, in the public interest for the Township of Monroe in the County of Gloucester and in the State of New Jersey, in order to foster and promote relief of waters from pollution and abate the menace to public health. These Rates, Rules and Regulations are established for the conduct of the Authority's business, to cover the use of sanitary sewers, pump stations and sewage treatment plants, water distribution systems; wells, reservoirs, standpipes, elevated tanks and all items related to public sewer systems and water works, to provide a schedule of fees and rates, and to outline allowable procedures and whatever else is deemed proper within the sphere of the Authority's activity.

### **1.B. Office of Authority and Hours of Business**

The principal office of the Authority, place of business and mailing address is 372 South Main Street, Williamstown, Gloucester County, New Jersey 08094.

The office of the Authority will be open for the purpose of the transaction of regular business between the hours of 7:30 A.M. and 3:30 P.M., prevailing time, each weekday, Monday through Friday, except holidays.

## 1.C. DEFINITIONS

Unless the context specifically indicates otherwise, the meaning of the terms used in these Rates, Rules and Regulations shall be as follows:

- 1.C.1. **Authority** shall mean the Monroe Municipal Utilities Authority and/or MMUA.
- 1.C.2. **Apartment** shall mean one of a series of attached one family dwelling units each having a common or party wall or walls between it and neighboring units, and which shares with its attached neighboring dwelling units such facilities as pedestrian walks gardens, lawns, utilities, sanitary systems, and recreation areas. Separate meters will be at the discretion of the Superintendent.
- 1.C.3. **Biochemical Oxygen Demand (BOD)** shall mean the quantity of oxygen utilized in the biochemical oxidation of organic matter under standard laboratory procedure in five (5) days at 20 degrees C, expressed in milligrams per liter.
- 1.C.4. **Building drain** shall mean that part of the lowest horizontal piping of a drainage system which receives the discharge from soil, waste, and other wastewater drainage pipes inside the walls of the building and conveys it to the building sewer, beginning five (5) feet (1.5 meters) outside the inner face of the building wall.
- 1.C.5. **Building sewer** shall mean the extension from the building drain to the public sewer or other place of disposal, also called house connection or lateral.
- 1.C.6. **Check valve** shall mean a valve which allows flow in a pipe one way only.
- 1.C.7. **Condominium** shall mean one of a series of attached one (1) family dwelling units each having common or party wall or walls between it and neighboring dwelling units. Each condominium unit shall have separate and individual utility systems.
- 1.C.8. **Customer** shall mean the applicant for water and/or sewer service at one household or business, whether owner or tenant, and who enters into an agreement therefore, which will be owner of record.
- 1.C.9. **Domestic Customer Unit** shall mean a single dwelling or structure normally occupied by a single family.
- 1.C.10. **Domestic Sewage** shall mean the normal waterborne fluid waste from residences, commercial establishments, institutions and industrial establishments, limited to the wastes from kitchens, bathrooms, water closets, lavatories, and laundries.
- 1.C.11. **Easement** shall mean an acquired legal right for the specific use of land owned by others.

- 1.C.12. **Floatable oil** is oil, fat or grease in a physical state such that it will separate by gravity from wastewater by treatment in an approved pretreatment facility. The wastewater shall be considered free of floatable fat if it is properly pre-treated, and the wastewater does not interfere with the collection system.
- 1.C.13. **Garbage** shall mean the animal and vegetable waste resulting from the handling, preparation, cooking, and serving of foods.
- 1.C.14. **Grease trap** shall mean a device designed with the primary purpose to assure free-flowing drainage through pipelines at all times by intercepting, separating, accumulating, and recovering grease from sanitary lines (see detail).
- 1.C.15. **Industrial wastes** shall mean the wastewater from industrial processes, trade, or business as distinct from domestic or sanitary wastes or sewage.
- 1.C.16. **Lateral** shall mean the service line owned by the customer and extending from the dwelling or establishment to the curb (as per MMUA detail and specifications).
- 1.C.17. **Main** shall mean the Authority owned or leased piping and appurtenances, in or along public highways and streets, or along privately-owned right-of-way, used for the transmission or distribution of water to or for the collection of domestic sewage or industrial wastes from its customer.
- 1.C.18. **May** is permissive (see Shall 1.28).
- 1.C.19. **Meter pit** shall mean a device which provides an area for placement of a water meter, and which is a self-contained isolated unit with applicable fittings to accept such meter (see detail).
- 1.C.20. **Person** shall mean any individual firm, company, association, society, corporation, or group.
- 1.C.21. **pH** shall mean the logarithm of the reciprocal of the hydrogen ion concentration. The concentration is the weight of hydrogen ions, in grams, per liter of solution. Neutral water, for example, has a pH value of 7.
- 1.C.22. **Properly shredded garbage** shall mean the wastes from the preparation, cooking, and dispensing of food that have been shredded to such a degree that all particles will be carried freely under the flow conditions normally prevailing in public sewers, with no particle greater than ½ inch (1.27 centimeters) in any dimension.
- 1.C.23. **Public sewer** shall mean a common sewer controlled by a governmental agency or public utility.

- 1.C.24. **Sanitary sewer** shall mean a sewer that carries liquid and water-carried wastes from residences, commercial buildings, industrial plants, and institutions together with minor quantities of ground, storm and surface water that are not admitted intentionally.
- 1.C.25. **Service Unit** shall mean equivalent service unit and shall be equal to a dwelling unit using the annually recomputed GPD ( gallons per day) according to N.J.S.A. 40:14-21 and 40:14B-22.
- 1.C.26. **Sewage** is the spent water of a community. The preferred term is “wastewater”.
- 1.C.27. **Sewer** shall mean a pipe or conduit that carries wastewater or drainage water.
- 1.C.28. **Shall** is mandatory (see May, 1.18).
- 1.C.29. **Single Family Dwelling** shall mean a building on a lot designed and occupied exclusively as a residence for one family.
- 1.C.30. **Slug** shall mean any discharge of water or wastewater which, in concentration of any given constituent or in quantity of flow, exceeds for any period of duration longer than fifteen (15) minutes more than five (5) times average twenty-four (24) hour concentration flows during normal operation and shall adversely affect the collection system and/or performance of the wastewater treatment works.
- 1.C.31. **Storm drain** (sometimes termed “storm sewer”) shall mean a drain or sewer for conveying water, groundwater, subsurface water, or unpolluted water from any source.
- 1.C.32. **Superintendent** shall mean the superintendent or general manager of wastewater facilities; and/or wastewater treatment works, and/or of water pollution control of the Township of Monroe, or his authorized deputy, agent, or representative.
- 1.C.33. **Suspended solids**, referred to as non-filterable residue, shall mean total suspended matter that either floats on the surface of, or is in suspension in, water, wastewater, or other liquids, and that is removable by laboratory filtering as prescribed in “Standard Methods for the Examination of Water and Wastewater,” 24<sup>th</sup> edition published December 1, 2022 jointly by the American Public Health Association, America Water Works Association, and Water Environment Federation.
- 1.C.34. **Townhouse** shall mean one of a series of attached one family dwelling units each having common or party wall or walls between it and neighboring dwelling units and having an individual rear yard contiguous to the dwelling unit designed as an integral part of each one family dwelling unit and from which the occupants of the dwelling unit shall have the

right to exclude the public. Each townhouse shall have separate and individual utility systems.

**1.C.35. Township** shall mean the Township of Monroe, Gloucester Co., New Jersey.

**1.C.36. Unpolluted water** is water of quality equal to or better than the effluent criteria in effect for the receiving water, or water that would not cause violation of receiving water quality standards.

**1.C.37. Wastewater** shall mean the spent water of a community. From the standpoint of source, it may be a combination of the liquid and water-carried wastes from residences, commercial buildings, industrial plants, and institutions, together with any groundwater, surface water, and stormwater that may be present.

**1.C.38. Wastewater facility** shall mean the structures, equipment, and processes required to collect, carry away, and treat domestic and industrial wastes and dispose of the effluent.

**1.C.39. Wastewater treatment works** shall mean an arrangement of devices and structures for treating wastewater, industrial wastes, and sludge. Sometimes used as synonymous with “waste treatment plant” or “wastewater treatment plant” or “water pollution control plant.”

**1.D. REFERENCED STANDARDS & AGENCIES**

Certain agencies and their standards are referenced within these Rules and Regulations and may be referred to when business is conducted with the Monroe Municipal Utilities Authority. When standards are referred to by specific numbers and/or dates, those standards have been deemed to be current at the time of adoption and/or amendment of the Rules and Regulations. In the event that any such standards have been revised or updated subsequent to the adoption or amendment of the Rules and Regulations, the more current edition of those standards shall be adhered to. The agencies and standards referenced may include, but not be limited to those listed below.

1.D.1. **AASHTO:** The American Association of State Highway and Transportation Officials.

1.D.2. **ADA:** The Americans with Disabilities Act.

1.D.3. **ANSI:** The American National Standards Institute.

1.D.4. **APHA:** The American Public Health Association.

1.D.5. **ASTM:** The American Society for Testing Materials.

- 1.D.6. **AWWA:** The American Water Works Association.
- 1.D.7. **DRBC:** The Delaware River Basin Commission.
- 1.D.8. **DVRPC:** The Delaware Valley Regional Planning Commission.
- 1.D.9. **GCUA:** The Gloucester County Utilities Authority.
- 1.D.10. **ISO:** The Insurance Services Office.
- 1.D.11. **N.J.A.C.:** The New Jersey Administrative Code.
- 1.D.12. **NJBPU:** The New Jersey Bureau of Public Utilities.
- 1.D.13. **NJDEP:** The New Jersey Department of Environmental Protection.
- 1.D.14. **NJDOT:** The New Jersey Department of Transportation.
- 1.D.15. **N.J.S.A.:** The New Jersey Statutes Annotated.
- 1.D.16. **OSHA:** The Occupational Safety and Health Administration; a branch of the United States Department of Labor.
- 1.D.17.: **PEOSH:** The Office of Public Employees Occupational Safety and Health; a branch of the New Jersey Department of Health.
- 1.D.18. **RSIS:** The New Jersey Residential Site Improvement Standards (N.J.A.C. 5:21)
- 1.D.19. **WEF:** The Water Environment Federation.

End of Section

## SECTION 2 - DOMESTIC SERVICE

### 2.1 Service to New Customer Through Existing Connections

- 2.1.1 No new service will be extended by the Authority until the Applicant has paid all charges due by the Applicant at any premises now or heretofore occupied by him. All water and sewer charges are municipal liens. All charges will be submitted by the Authority prior to the date of settlement and verified in written form to the title company or whatever authorized agent is processing the transfer of property. The title company shall be obligated to clear all water and/or sewer charges outstanding on the property. In the event that charges are not paid at settlement, those charges shall remain on the account as a lien against the property.
- 2.1.2 The Authority shall charge a search fee (See Schedule 21) for water and sewer on each inquiry. Such fees are due upon presentation. Failure on the part of the title company or the proper authorized agent to pay the search fees within 20 days of presentation will result in the discontinuance of Authority lien information.
- 2.1.3 No Authority approval will be given to the Building Inspector for issuance of a Certificate of Occupancy until the Authority has certified that the meter, meter wiring for remote readout and water and sewer lateral system have been installed in accordance with the Authority Rates, Rules, and Regulations.
- 2.1.4 Under no circumstances shall any new fixture be installed in a building or dwelling at an elevation lower than the front curb elevation or the street centerline elevation, whichever is higher, unless special precautions are incorporated into the new fixture installation to prevent surcharging of the new fixture installation from the sanitary sewer main because of high flow or blockage. Prior to installation of any fixture which may be lower than the elevation heretofore specified, the Owner shall obtain the approval of the Township Plumbing Inspector on the type of precautions that will be taken to eliminate the potential flooding of premises with sewage. Owners of houses where the Authority has deemed it necessary that such precautions had to be installed, will be notified by certified mail of the requirement for the installation of that check valve system and they will be advised that they own the system and its maintenance is their responsibility and that the Authority cannot be held responsible for any damage as a result of its malfunctioning.
- 2.1.5 Assessment of water charges will begin after issuance of connection permit. Assessment of sewer charges will begin on the date of the Certificate of Occupancy is issued.
- 2.1.6 The Applicant shall be responsible to install electrical wiring from the water meter

to the remote readout location as determined by the Authority Superintendent.  
(if applicable)

**2.2 Landlord-Tenant Responsibility** All charges for sewer and water are a lien against the property and therefore the responsibility of the property owner.

**2.3 Discontinuation of Customer Service** In the event that a sewer lateral service will be permanently discontinued, the Authority shall be notified in writing that the service billing shall be terminated. The sewer lateral shall be permanently sealed watertight in a manner subject to the approval of the Engineer or Superintendent.

**2.3.1. Permanently Discontinued Service** Permanently discontinued sewer service laterals will not be recognized by the Authority as an M.U.A. connection. A new application for service along with the current connection fee for sewer and water county expansion permit, will be required if the property owner requests a renewal of service. Authority administration staff will advise, in writing to the property owner at the time of discontinuance of customer service, the aforementioned rule.

**2.4 Tampering with the Meter** Where the meter has been inspected and found to have been removed, damaged or tampered with, the service to the customer shall be discontinued immediately. Restoration of service will require a restoration fee and a service charge to repair the meter and appurtenances.

End of Section

## SECTION 3 - PUBLIC FIRE SERVICE

### 3.1 Hydrant Locations

Hydrants in new projects to be constructed shall be within 400 feet radius of each other and the distance between hydrants, as measured by the curb length, shall be no more than 800 feet.

Unless approved otherwise by the Authority, fire hydrants should be placed at street intersections so as to maximize the number of homes within the proximity of each hydrant as well as to make them easier for the Fire Department to locate when they are needed for fire suppression. In addition, whenever practicable fire hydrants should be placed on the side of the street nearest the water main. Such placement would reduce the amount of pipe needed for each hydrant and minimize the number of crossings of other utilities with the fire hydrant service main. Where longer streets require the placement of additional fire hydrants between street intersections, the hydrants shall be placed at property corners wherever practicable.

Subdivision plans, as approved by the Authority, shall be submitted to the Fire Marshal for his approval of hydrant locations. The written and dated signature of the Fire Marshal or his duly authorized representative from the municipality, on each set of plans submitted by the Authority, shall constitute authorization from the municipality.

### 3.2 Maintenance

The Authority will maintain all fire hydrants except those approved by the Authority for private ownership and maintenance. Privately-owned and operated fire hydrants shall be subject to all other applicable rules and regulations of the Monroe Municipal Utilities Authority.

### 3.3 Allowable Uses

Only persons authorized by the Authority shall take water from any public fire hydrant, except for fire purposes, or for the use of the Fire Department, in case of fire. No public fire hydrant shall be used for sprinkling streets, flushing sewers or gutters, or for any use other than fire purposes, except with the written approval and consent of the Authority.

### 3.4 Change of Location

Whenever the municipal governing body desires a change in the location of any fire hydrant, the Authority, upon written notice to do so, will make such change at the expense of the municipality, providing the new hydrant location remains in compliance with the Authorities current Rules and Regulations.

### 3.5 Inspection

Routine inspections of each hydrant shall be made semi-annually according to the time schedule set by the Superintendent. Upon written request from a duly authorized representative of the municipality, the Authority, when it determines that the request is reasonable, will authorize that such inspection be made by an authorized representative of the Authority, accompanied by an authorized representative of the municipality.

### 3.6 Notification

The Police Dispatcher and Fire Department shall notify the Authority when the Fire Companies will be using a hydrant.

### 3.7 Additional Valves

Valves are required along each node of all water main intersections, unless approved otherwise by the Authority. In addition, in residential developments valves shall be located on distribution mains so that not more than one fire hydrant would be placed out of service due to a water main break or valve closure.

For long runs of pipe constructed offsite from residential development, valves shall be placed at intervals not exceeding 1600 feet.

Whenever practicable valves should be placed in close proximity to fire hydrants to facilitate ease of location by operations personnel.

End of Section

## SECTION 4 - PRIVATE FIRE SERVICE

**4.1 Automatic Devices and Hydrants** For automatic sprinklers or other automatic fire service devices located inside a building or buildings, a separate service line may be required, to be used exclusively for fire service. In determining the size of service line, a flow test may be required. The figures obtained during the flow test show conditions of the water system during the time of the test taken. We do not guarantee that these pressures and quantities will not vary due to change in system load. At the option of the customer, fire hydrants located outside of the building may be connected to the fire service line. Each such separate service line shall be subject to the charges shown in the rate schedule.

**4.2 Ownership and Location** All meters for private fire service shall first be approved by the Authority but shall be furnished and installed by the customer. Meters will be set in an approved type of brick or concrete masonry vault, adequately drained, located on the premises of the customer or in an approved above ground building/structure when the Authority deems necessary. The meter vaults/buildings are to be constructed and maintained at the expense of the customer.

**4.3 Private Un-metered Fire Service** When, in the judgement of the Authority, it is practical, private un-metered fire service lines may be permitted to be installed at the expense of the owner and shall be subject to the charges shown in the rate schedule.

**4.4 Bills Rendered and Due** Bills will be rendered quarterly on the date shown on the Authority Voucher. All bills are due and payable on presentation.

End of Section

## SECTION 5 - USE OF WATER FOR BUILDING PURPOSES

### Special Application

A supply of water for building or other special purposes, except on a lot or premises already supplied with a metered water connection, must be specially applied for and fees paid as specified in Section 21 - Schedule 2. All applications for water for building purposes must be signed by the owner or his duly authorized agent and shall be interpreted to mean that the water is to be used from a builder's hydrant.

End of Section

## SECTION 6 – WATER AND/OR SEWER APPLICATION – GENERAL

### 6.1 General Provisions

Persons proposing subdivisions or site plans requiring a main extension, but not necessarily requiring NJDEP permits, for sewer or water service shall prepare applications described in this section with the necessary supporting documents. The policy of the Authority is to permit extensions only when paid for and installed by the applicant. It is also the Authority's policy to permit extensions only when all such extensions and appurtenances would lie completely within the municipal boundaries of the Township of Monroe. No facilities for collection, treatment, or disposal of sewage or for the distribution of water within the "district" of the Authority (which corresponds with the boundaries of the Township) shall be constructed unless the Authority shall give its consent and the Authority Engineer shall approve Contract plans and specifications therefore.

It is the policy of the Authority to charge connection fees for connection to its water and sewer system following the rates of Section 21.

Connection fees at prevailing rates shall be payable within 30 days of approval of application for construction approval Form C by the Authority unless specific arrangements are agreed upon. If payment is not received within this 30-day period, the connection fee shall be at the prevailing rate at the time of receipt of the check.

#### 6.1.1 Auxiliary Electrical Power

##### 6.1.1.1. General Requirements

Auxiliary electrical power is required for all motors used for wells, lift station and other motor driven equipment as determined by the Authority. This shall apply to all major projects, which major project is defined as including but not limited to major subdivisions, general commercial projects and multiple occupancies in the excess of three domestic customer units. The Authority reserves the right to make exceptions to the above requirement when it appears the imposition thereof will be patently inequitable.

##### 6.1.1.2. Permanent Auxiliary Electrical Power

Permanent auxiliary power generators shall be made part of any motor driven equipment as deemed necessary by the Authority's Engineer and shall be included as a cost of that equipment. The power generator shall be in proper housing of a type and/or design to be approved by the Authority Engineer. (See Section 12.13.1C).

The developer shall be fully responsible for ensuring the generator has been designed to meet all operational requirements of the Authority. The design must account for all electrical loading at the facility requiring permanent auxiliary power. Neither the Authority nor the Authority Engineer shall assume any responsibility for the design or performance of the auxiliary generator. The auxiliary generator shall be subjected to testing in accordance with the Authority policies and procedures and the test results must be deemed satisfactory by the Authority and Authority Engineer as a prerequisite to acceptance under the Authority Form D application. In no event shall the generator experience a fifteen percent (15%) drop in voltage during operation.

The developer shall be responsible for obtaining an Air Quality Permit from the New Jersey Department of Environmental Protection (NJDEP) when required by the Rules of the NJDEP Bureau of Air Pollution Control (N.J.A.C. 7:27-1 et seq.). Pursuant to N.J.A.C. 7:27-8.2(c), a permit shall be required when the emergency generator has a maximum rated heat input of 1,000,000 BTU per hour or greater.

#### **6.1.2 Connections**

Residential subdivisions containing four (4) or more contiguous building sites or lots or any residential structure to be used by three or more families, regardless of volume of flow, and all nonresidential developments such as schools, commercial buildings, industrial buildings and all other structures, may be required to install a sanitary sewer system and water distribution system to be connected with the nearest existing sanitary sewer and existing water main in the Township.

Residential subdivisions containing three or less building sites or lots or if the lands are deemed by the Authority to be too remote from any existing facilities, then consideration will be given to an individual sewage system, with a dry sanitary sewer system for future use, in lieu of connecting to existing facilities. Individual sewage disposal systems will be permitted only upon specific written permission of the Authority.

If the lands are deemed by the Authority to be too remote from an existing water main or if the volume of potable water required is greater than capabilities of the existing facilities, then consideration will be given to a new water supply and/or storage facilities or the installation of dry water mains for future use. Such individual system, plant or expansion of the location thereof shall be subject to approval by the Authority in accordance with the standards and requirements as hereinafter set forth.

Any main and related facilities installed under the provisions of this section shall be transferred to the Authority hereinafter described.

During construction, but before final acceptance, the Authority shall have the right to use any completed portion of the system without waiving its right to further inspection or testing or to order correction of any defects.

Use of the sanitary sewer system for the discharge of sump pumps, or drainage from cellar drains, leaders, downspouts, drainage tile, swimming pools, cooling system drainings and other similar discharge shall not be permitted.

Unpolluted industrial cooling waters and unpolluted drainage shall be discharged into a storm sewer or natural outlet.

These General Provisions are and shall be subject to the existing contractual obligations outstanding.

## **6.2 Applications – General**

A sequence of applications for sewer and water extensions are required for the Authority's determination of needs, availability of service, effect of proposed extension, and inspection of installed extension. Application forms are available from the Authority. Section 6 outlines the contents and sequence of applications, forms, supporting data, fees and Authority action that results in acceptable main extensions for water and sewer. No application will be considered unless a Professional Engineer, registered in the State of New Jersey is in charge of the planning and design of the proposed sewerage and water distribution facilities and has affixed his seal and signature thereto. Each application shall be submitted in duplicate with the designated fee to the Authority not less than thirty (30) days before the Authority meeting at which action on the application is desired.

Applications shall be signed by the Owner or Owners, or by a proper official of the company, or, if signed by an authorized agent, a certified copy of the authorization of the company shall be attached to the application.

All fees accompanying applications shall be cash, certified check or acceptable other draft at the option of the Authority. Escrow fees are due with application submission. Outstanding balances will be refunded after all obligations have been met by the Authority at the time of total project completion, and legal acceptance by resolution or at the time of rejection. Before proceeding to the next level of application, it may be necessary to satisfy any outstanding deficit at the preceding application level.

### **6.2.1 Duration and Expiration of Approvals**

Approvals of Form A and Form B applications shall remain valid for the time periods specified in the respective subsections for those applications below.

### **6.3 Application of Feasibility – Form A**

#### **6.3.1 Purpose of Application**

An application describing the proposed subdivision of development (residential, commercial, industrial or other) shall be submitted to the Authority with supporting data to determine the economic and technical feasibility of extending sewer and/or water service. The Authority may defer or waive certain parts of this supporting data at its discretion where the cost of data preparation is not commensurate with the development or project planning approvals.

#### **6.3.2 Forms and Supporting Data**

FORM A: APPLICATION FOR REPORT ON FEASIBILITY OF PUBLIC SEWER AND/OR WATER, RECOMMENDATIONS AND CONDITIONS. In addition to preparation and submission of the application, the applicant shall furnish a general location plan showing streams, streets, blocks, lots, and tax map numbers, copy of application submitted to the Planning Board if required, location of any existing water distribution and/or sanitary systems in the area, proposed system outline and route of construction, and estimated volume of flow.

#### **6.3.3 Fee**

Refer to Application

#### **6.3.4 Action by Authority**

The Authority shall analyze the submitted application and supporting data and report to the applicant the Authority's recommendation and/or finding. This report shall be within 30 days of the receipt of the application.

#### **6.3.5. Subdivision and Site Plans**

On all Subdivision and Site Plans the Authority shall issue a Form A "Report on Feasibility" to the applicant for his submittal to the Planning Board for their classification of sketch plan or conceptual plans for this project.

If the Authority determines that the proposed subdivision or development is too remote for extending sewer and/or water service, or contains three or less building sites or there are other circumstances peculiar to this application, the Authority may do the following:

- (a) Waive the application and fee.

(b) Send Water/Sewer Waiver form to Install Onsite Disposal Systems and/or Potable Water System as Approved by the Board of Health to the applicant, construction official, and the County Board of Health.

(c) Approve the application and waive all subsequent applications.

#### **6.3.6 Commercial or Industrial**

All commercial water meters two inches or larger shall be tested and inspected by a qualified meter testing company every two years to ensure the accuracy of the meter. The test results shall be submitted to the Monroe Municipal Utilities Authority within fifteen (15) days of testing, along with: documentation of the testing company's qualifications; meter location; make, model and serial number of meter; and confirmation there is an operable valve on both sides of and within 24 inches of the meter. Any meter found to be inaccurate by  $\pm 3\%$  shall be removed and replaced with a new or re-conditioned meter within fifteen (15) days from the date the test results were documented. The replacement meter shall be tested and all information described above shall be submitted to the Authority with the test results. All costs relating to compliance of the metering requirements shall be the responsibility of the property owner. Failure to comply with these requirements would be cause for termination of service.

#### **6.3.7. Approval and Expiration**

Form A approval shall remain in effect for a 2-year period from the date of approval. If no Form B application has been submitted within the 2-year period, the Form A approval will expire and any funds remaining in the escrow account will be returned to the applicant. The applicant may request and the Authority may grant extensions on the approval for additional periods of one year but not to exceed a total extension of two years.

### **6.4 Application for Preliminary Approval – Form B**

#### **6.4.1. Purpose of Application**

An application and supporting data specifying the engineering details of the proposed project will be analyzed for compliance with Authority engineering standards including provisions for orderly growth.

This form is filed as an initial request after approval of Form A on all subdivisions.

#### 6.4.2. Forms and Supporting Data

FORM B – APPLICATION FOR PRELIMINARY REVIEW OF PLANS FOR PUBLIC SEWER AND/OR WATER. The application shall be accompanied by two (2) copies and 1 PDF copy of the Engineer’s Report as described in Section 12.6 and 13.4.

In addition, applicant shall submit all data required by the current Rules and Regulations of the Gloucester County Utilities Authority and the New Jersey Department of Environmental Protection. The applicant shall submit the Sewer and/or Water Permit Application and the applicant shall pay all fees of the Gloucester County Utilities Authority and the New Jersey Department of Environmental Protection. Permits to construct sewers, water mains and/or other structures within flood plains, wetlands and the right-of-way limits of state, county, municipal roads and all railroads, and all other permits must be secured by and paid for by the applicant.

The applicant must inform and secure any necessary clearance and/or approval from any public utility involved. Proof of such notice and/or approvals shall be filed with the Authority.

The applicant shall file the following fully executed papers with the Authority for the submission to the New Jersey Department of Environmental Protection (NJDEP) for State sewer and/or water permits:

##### For Sewer Permit Submittal

- Two (2) copies and 1 PDF copy of completed NJDEP standard forms (Form TWA-1; Form WQM-003; Form WQM-006)
- Two (2) copies and 1 PDF copy of completed Dry Sewer Affidavit (if required by the Gloucester County Utilities Authority)
- Two (2) copies and 1 PDF copy of Engineer’s Report on Sanitary Sewer System
- Two (2) copies and 1 PDF copy of Site Plan and/or Subdivision Plans
- Two (2) copies and 1 PDF copy of Municipal Utilities Authority approved sanitary sewer plans and profiles
- Two (2) copies and 1 PDF copy of Sanitary Sewer Specifications

- Two (2) copies and 1 PDF copy of the Letter of Concurrence from the County Utilities Authority

#### For Water Permit Submittal

- Two (2) copies and 1 PDF copy of Engineer's Report for Potable Water System
- Two (2) copies and 1 PDF copy of Municipal Utilities Authority approved Potable Water Plans
- Two (2) copies and 1 PDF copy of Site Plans and/or Subdivision Plans
- Two (2) copies and 1 PDF copy of Potable Water Specifications

The applicant must execute a developer's agreement to be prepared by the Authority Solicitor as a prerequisite to Form B approval.

#### **6.4.3 Fee**

Refer to Application.

#### **6.4.4. Action by Authority**

The application and supporting data will be reviewed by the Authority to determine compliance with the Authority's comprehensive water and sewer plans, these Rates, Rules and Regulations and Supplements thereto, applicable statutes, and projected growth patterns. A report from the Engineer shall be done within 30 days of receipt of the application. A final condition of approval of this application shall be a mutual agreement between the applicant and the Authority regarding the terms and conditions for providing sewer and water service.

Any agreement at this stage would be conditioned upon the necessary endorsement from the GCUA and receipt of the approved permit from the NJDEP, if required. A major element of this agreement shall include the legal description for all easements to be dedicated to the Authority as well as proof of executed easement agreements for water and sewer facilities that traverse land not owned by the applicant. Both easement legal descriptions and easements agreements shall include any restrictions prohibiting installation of fencing, shrubbery and other landscaping on any easements to be turned over to the MMUA.

Prior to Authority approval, when the Authority has approved the plans, the applicant must execute the developer's agreement and then the Authority will adopt a resolution authorizing submittal of plans to NJDEP for state sewer permit.

Upon notification by the Authority that approval from the NJDEP has been given to the proposed project and necessary sewer permits have been received from NJDEP, the applicant may file an application or series of applications for Construction Approval (see paragraph 6.5) within a period not to exceed two (2) years from the date of approval by the Authority, or from the date of receipt of NJDEP permits that may be required, whichever is the later date, unless otherwise waived by the Authority if such waiver is within the jurisdiction of the Authority.

#### **6.4.5. Approval and Expiration**

Form B approval shall remain valid for a period of 2 years from the date of approval unless a Treatment Works Approval Permit (TWA Permit) is issued by the NJDEP. If a TWA Permit is issued, the Form B approval will remain valid as long as the TWA Permit remains in effect. Upon issuance of a TWA Permit, the Form B approval shall remain valid and expire concurrently with the TWA Permit.

If a TWA Permit is not obtained within 2 years from the date of Form B approval, the approval shall expire unless an extension is granted. The applicant may request and the Authority may grant extensions on the Form B approval for additional periods of one year but not to exceed a total extension of two years.

### **6.5 Application for Construction Approval – Form C**

#### **6.5.1 Purpose of Application**

Following approval of the application for approval for a period not to exceed two years, the applicant may apply for construction approval. This application may be submitted as a sequence of applications as each segment of the total approved project is scheduled for construction. This application provides a control on the extent and schedule of planned sewer and water facilities installation and establishes a schedule for Authority inspection of completed installations.

#### **6.5.2. Forms and Supporting Data**

FORM C – APPLICATION FOR CONSTRUCTION OF PUBLIC SEWER AND WATER SYSTEM. Where the plans of final sections which are being submitted for authorization to construct are identical to those approved by the Authority and the NJDEP. However, the project Professional Engineer shall sign, seal, and certify a letter attesting to the accuracy of plans.

The application shall be accompanied by two (2) sets of final data as approved of the Form B approval, as per paragraph 6.4.2. This data will be the basis of construction approval, inspection and testing. Requested major revisions will be

treated as resubmissions of Approval requiring review and approval. Such revisions are subject to the requirements of paragraph 6.4 in its entirety.

If any portions of the water or sanitary sewer systems are to be constructed within easements, the Form C application shall be accompanied by legal descriptions and easement plans. A separate legal description and plan of easement shall be prepared for each lot affected by said easements.

This application shall also include fire hydrant plans as approved by the Fire Marshal.

### **6.5.3. Performance Bond or Surety Documents**

A Performance Bond or Surety Documents, satisfactory in form to the Authority, shall be submitted to the Authority prior to Authority approval of the application. The Bond of cash or certified check shall be in the amount of 120% of the total estimated construction cost, as verified by the Authority, for the Final Section or Sections covered by the application. Said estimated construction cost shall be determined by the Authority Engineer. This Bond or cash or certified check shall guarantee complete construction within the time period specified by the Authority and shall further guarantee that said construction shall be in accordance with the final plans and specifications approved by the Authority and NJDEP.

The Bond or Surety Documents shall remain in effect until the sanitary sewer collection system and related appurtenances and/or the water distribution system and related appurtenances are installed, tested and protected by an adequate layer of flexible bituminous paving or approved equal. Subject to the recommendation and approval of the Authority Engineer, the Bond or Surety Documents will be released upon receipt of two-year Maintenance Bond equal to fifteen percent (15%) of the construction cost.

The developer shall continue to be completely responsible for this section of the system until it is legally accepted by Authority Resolution. A section is typically legally accepted after the completion of the final road surfacing when the sewer and water systems receive final inspection and approval from the Authority Engineer.

For projects with wastewater pump stations to be dedicated to the Authority, the pump station and force main shall be bonded separately from the rest of the development. The pump station and force main shall not be considered part of any individual section or phase within the development.

#### **6.5.4. Fee**

Refer to Application.

#### **6.5.5. Action by Authority**

Within 30 days of receipt of the application, a review report from the Engineer will be provided. Upon approval of the application, the Authority shall grant approval for construction of the project to the extent requested and subject to the receipt of the necessary permits from the State and all other agencies.

For projects with wastewater pump stations, the new pump station must be complete and build in accordance with the approved plans and specifications before the first meter is installed to service the development. Prior to a pump station being placed into service, the wastewater pumps and auxiliary generator shall be subjected to testing in accordance with the Authority policy and procedures, and those test results must be deemed satisfactory by the Authority Superintendent and Engineer. In addition, the applicant shall provide the Authority with all pertinent data pertaining to the pump station equipment, including: pump make and model, impeller model, motor horsepower, total dynamic head, and make, model and size of generator.

Upon satisfactory completion of testing, the pump station may be placed into service and the first meter may be installed. It is the sole discretion of the Authority to determine if the pump station will remain privately owned or if the Authority will assume responsibility for operation and routine maintenance of the pump station. In the event the Authority consents to transfer and accept ownership of the pump station and upon issuance of the first connection permit and issuance of the meter, the Authority shall assume responsibility for operation and routine maintenance of the pump station, so as to ensure compliance with Authority standard operating procedures.

The developer shall retain responsibility for completion of all site work on the pump station lot as well as completion and repair (if and when necessary) of all equipment to be constructed in accordance with the approved plans. The Authority shall retain said operation and routine maintenance responsibility until a maximum of 50 meters have been installed or a 2 year time period has elapsed, whichever comes first. Prior to issuance of a 51<sup>st</sup> meter or at the end of a 2 year period of operation after the pump station was placed into service, the developer shall submit a Form D application for title transfer of the pump station in accordance with the policies described below. The performance surety shall remain in place until approval of the Form D application and acceptance of a maintenance bond in its place.

## 6.6 Application for Acceptance – Form D

### 6.6.1 Purpose of Application

The purpose of the Form D application is to verify and document completion of the water and/or sanitary sewer facilities in accordance with the approved plans and with Monroe MUA and NJDEP rules and regulations, whether they are to be privately owned or if ownership is to be transferred to the Monroe MUA.

Upon satisfactory completion of construction, inspection, and testing, the applicant shall request the Authority to accept the installed system and release developer's escrow. Sufficient funds shall be retained in the escrow account to cover the costs of inspection fees at the end of the 2 year term of the maintenance bond. The amount to be retained shall be determined by the Authority Engineer.

Ownership, maintenance and operation of the system shall be the responsibility of the Authority only after a specific written acceptance by the Authority for the system, whether it is in whole or part as issued by the Authority. If and until the Authority issues this written acceptance, the ownership, maintenance, and operation shall remain the responsibility of the applicant.

### 6.6.2. Forms and Supporting Data

FORM D – APPLICATION FOR TITLE TRANSFER, PUBLIC SEWER AND WATER SYSTEMS. When the Authority Engineer has determined that the project is completed and ready for legal acceptance by the Authority, he will submit a letter of certification that it has been built in accordance with the plans and specifications as approved by the Authority. The applicant will then be notified to submit the following data:

- (a) All necessary documents approved by the Authority that will permit the dedication of all necessary property and easements that are inherent and necessary part of the completed project.
- (b) Proof of payment of all fees and charges required by the Rules and Regulations up to and including this application.
- (c) Proof of release of liens from all contractors, subcontractors, and material suppliers.
- (d) Proof that all construction "as-builts" have been submitted by the contractor to the Authority Engineer.

- (e) Submit a Maintenance Bond in the amount of 15% of the bonding costs for a two (2) year time period.
- (f) Applicant must televise the sanitary sewer mains as a condition of approval.
- (g) As-built plans, prepared by the applicant's engineer, providing the information pertaining to the completed water/sewer system described below.

### 6.6.3 As-built Plans

The Developer's Engineer shall be responsible to perform an as-built survey of the project and submit two (2) paper copies and sealed by a New Jersey Licensed Professional Land Surveyor along with an electronic copy in AutoCad format (Version 2000, Release 2 or newer) of the final development showing the water and sewer main infrastructure, and the on-site and off-site utilities serving the project. The "as-built" plans shall contain all pertinent information such as, but not limited to, manhole-to-manhole distances, inverts and rim elevations required, street addresses, sizes and types of pipe material, location of all tees, valves, fire hydrants, blow-offs, and also certifications as detailed herein.

For projects including pump stations to be dedicated to the Authority, the as-built plans shall include a complete property and topographic survey of the completed pump station. In addition, the as-built plans shall include pipe elevations at 100-foot stations as well as at all high and low points along the route of the force main. Any and all structures such as air release manholes, shall also be located with rim and invert elevations.

The Developer's Engineer shall also be required to submit as-built data information in the following format for inclusion into the Authority's GIS System:

- All mapping shall be performed in Arc View Format, Release 3.2 or newer.
- All Arc View shape files and attributes shall meet Authority's standard format.
- All mapping shall be formatted on NJ State Plane Coordinates NAD 83, and NAVD 88 Vertical Datum.
- All mapping and attribute information must be in strict accordance to accuracy standards required by the NJ Department of Environmental Protection Geographic Information System for "Mapping and Digital Data Standards".

Should the developer request the Authority to perform these as-builts, the developer must submit a letter requesting the Authority Engineer to perform the services and the developer's escrow account will be charged according to the developer's escrow agreement.

### Checklist Items for As-Built Plans – MMUA

#### All Plans:

- Property Block and Lot numbers
- Property street address numbers

#### Water Distribution System

##### Water Mains:

- Show physical location of water mains
- Label water main pipe size
- Label water main pipe material

##### Water Valves:

- Show location of water valves
- Label size of valve

##### Fire Hydrants:

- Show fire hydrant locations
- Label as fire hydrant

##### Fittings:

- Show locations of fittings (tees, bends, crosses, reducers, etc.)

##### Appurtenances:

- Show locations of water meter pits and water service valves (curb stops)

#### Wastewater Collection/Conveyance System

##### Manholes:

- Show manhole locations
- Label as manhole or drop manhole, as appropriate
- Label rim elevations (proposed and as-built)
- Label invert elevation(s) (proposed and as-built)
- Label manhole number as shown on design plans

##### Gravity Sewer Mains:

- Show physical location of sewer mains
- Label size of sewer main pipe
- Label sewer main pipe material

- Label length of pipe between manholes (proposed and as-built)
- Label slope of pipe between manholes (proposed and as-built)

Force Mains:

- Show location of force main
- Label force main size
- Label force main pipe material
- Label length of pipe between manholes (proposed and as-built)
- Label slope of pipe between manholes (proposed and as-built)

#### **6.6.4. Form D Applications for Pump Stations and Force Mains**

If ownership of the pump station is to be transferred to the Authority, upon completion of the project, at the end of a 2-year period of operation of the pump station, or prior to issuance of the 51<sup>st</sup> meter, whichever comes first, the developer shall submit a Form D application for title transfer of the pump station. A complete pump station site inspection shall then be conducted, and the wastewater pumps and auxiliary generator subjected to re-testing in accordance with Authority policies and procedures. Upon completion of successful testing and acceptable inspection of the pump station site, the Authority shall grant Form D approval. This approval must be granted by formal resolution prior to acceptance of ownership of the pump station and issuance of the 51<sup>st</sup> meter. The developer may, at their discretion, submit the Form D application in advance of the 50<sup>th</sup> meter to initiate inspection of the facilities. However, the Authority shall not grant Form D approval until after installation of the 50<sup>th</sup> meter.

#### **6.6.5 Action by the Authority**

Within 30 days of receipt of the application, a review report from the Engineer will be provided. Upon receipt of all required data from the applicant, the Authority will:

- (a) Instruct the Authority Engineer to prepare the final 24" x 36" as-built plans for the Authority record as per the Rules and Regulations.
- (b) Adopt a Resolution legally accepting the facilities.
- (c) Release the Performance Bond and accept the Maintenance Bond.
- (d) Maintain and operate the system thereafter unless it is to be privately-owned.

**6.6.6. Sewer and Water Connection**

Approved sewer and/or water connections shall be made to a street main only under the supervision and inspection of the Authority or the Authority Engineer. Connections to the sewer shall be made through an approved wye, saddle or manhole. Connection shall be made in accordance with the direction of the Authority and/or its Engineer, or any other Authority designee.

**6.7 Application for Connection of Public Sewer and/or Water Systems into Existing Authority System – Form E-A**

**6.7.1. Purpose of Application**

To determine the technical and economic feasibility of extending sewer and/or water to the Authority system and to verify that the systems will be constructed in compliance with the MMUA Rules and Regulations.

**6.7.2. Fee**

Refer to Application.

**6.7.3. Forms and Supporting Data**

Individual Residential Unit

FORM E-A – APPLICATION FOR CONSTRUCTION OF PUBLIC SEWER AND/OR WATER SYSTEM FOR AN INDIVIDUAL DWELLING UNIT INTO AN EXISTING AUTHORITY SYSTEM.

**6.8 Availability**

FORM E-D- APPLICATION PERTAINING TO AVAILBILITY OF WATER AND/OR SEWER.

Residential Unit:

To determine if service is available with regard to connecting into our existing sewer and/or water system.

Industrial or Commercial Unit:

To determine if service is available with regard to our existing water and/or sewer system.

## 6.9 Form C-2 – Change in Use Application

### 6.9.1. Purpose of Application

To determine if further engineering is needed and if any additional connection fees shall be assessed.

### 6.9.2. Fee

Refer to Application.

End of Section

## SECTION 7 - WATER AND/OR SEWER APPLICATION - COMMERCIAL - INDUSTRIAL

Industrial and commercial establishments, making application for water or sanitary sewer service in addition to making written application for such services, shall furnish a detailed description of the type and size of buildings, and nature to be served, the type, volume and chemical characteristics of the waste to be discharged. Such applicants shall also furnish the Authority four (4) copies of 24" x 36", or 36" x 42" plans showing at a scale no less than 1" = 100', the following:

- a) The boundaries of the property.
- b) The location within the property of the structures to be served.
- c) The location and profiles, with respect to finished grade of the services.
- d) Details of the proposed connections to the sewerage system, and arrangement and details of meter and sampler installation, should they be required.

### 7.1 Agreement Required

The Authority will accept industrial wastes into the sanitary sewage system, upon execution of a formal, written agreement, and under and subject to the provisions appearing in said agreement, and the rules stated hereinafter. The agreement will set out in detail the characteristics of the wastes, the flow conditions that shall govern the conditions and costs with respect to the physical connection or connections, and the annual service charges. It will be the policy of the Authority to consider each application on its merits, and to establish specific conditions applicable to the particular situation, for each agreement. No connection shall be made prior to execution of the agreement.

### 7.2 Applications for Construction Approval for Commercial or Industrial Applicants Forms A, B, & E-A . (For Forms C see section 6.5, Form D see Section 6.6)

A sequence of applications for sewer and water services is required for the Authority's determination of needs, availability of service, effect of proposed extension, and inspection of installed extension. Form A and B Applications are for all projects which require main extensions and/or are determined to need Authority Engineer review by the Authority Superintendent. The Form E-A Application is for projects which require lateral connects only to the Authority's existing system and are determined by the Authority Superintendent not to require review by the Authority Engineer. Application forms are available from the Authority. Section 6 outlines the contents and sequence of applications, forms, supporting data, fees, and Authority action that results in acceptable main extensions or lateral connections for water and sewer. No application will be considered unless a Professional Engineer, registered in the State of New Jersey is in charge of the planning and design of the proposed sewerage and water distribution

facilities and has affixed his seal and signature thereto. Each application shall be submitted in duplicate with the designated fee to the Authority not less than thirty (30) days before the Authority meeting at which action on the application is desired.

Applications shall be signed by the Owner or Owners, or by a proper officials of the company, or, if signed by an authorized agent, a certified copy of the authorization of the company shall be attached to the application.

All fees accompanying applications shall be made payable to the Monroe Municipal Utilities Authority. Escrow fees are for of application submission. Outstanding balances will be refunded after all obligations have been met by the Authority at the time of total project completion, and legal acceptance by resolution or at the time of rejection.

### **7.2.1 FORM A - APPLICATION FOR REPORT ON FEASIBILITY OF PUBLIC SEWER AND/OR WATER, RECOMMENDATIONS AND CONDITIONS**

This application determines the economic and technical feasibility of extending public sewer and/or water service to the municipal system. The approval of this application is the first step in obtaining MMUA Endorsement. In addition to preparation and submission of the application, the applicant shall furnish a general location plan showing streams, streets, blocks, lots, and tax maps numbers, copy of application submitted to the Planning Board if required, location of any existing water distribution and/or sanitary systems in the area, proposed system outline and route of construction, and estimated volume of flow.

Before reviewing an application for a connection involving the acceptance of industrial wastes, the applicant shall submit complete data with respect to the following:

- a) Average, maximum, and minimum rates of flow to be expected daily and seasonally.
- b) Flow diagram, showing points of application of chemicals, type, and quantity of each chemical used per day and per shift, a schedule of operations, expected chemical characteristics of the untreated wastes, and the point or points of connection to the sewerage system. The normal situation will require the separation of, and separate points of connection for domestic sewage and industrial wastes for each industrial establishment.

#### **7.2.1.1 Fees**

Refer to application

#### **7.2.1.2 Action by the Authority**

The Authority shall analyze the submitted application and supporting data and report to the applicant the Authority's recommendation and/or findings. This report shall be within 30 days of the receipt of the application.

#### **7.2.2 FORM B - APPLICATION FOR PRELIMINARY REVIEW OF PLANS FOR PUBLIC SEWER AND/OR WATER**

This application and supporting data specifying the engineering details of the proposed project will be analyzed for compliance with Authority engineering standards including provisions for orderly growth. The final condition of approval will be a mutual agreement between the applicant and the Authority regarding the terms and conditions for providing water and sewer service.

Supporting data shall consist of two (2) sets of drawings, reports, and other pertinent data as outlined in the Form B Application describing details of the sanitary sewer system and water distribution systems, including fire hydrants, private fire service and sprinkler systems as approved by the Fire Marshall. If additional data is required after the initial review, the applicant will be contacted to submit same to the Authority.

##### **7.2.2.1 Fees**

Refer to Application.

##### **7.2.2.2 Action by Authority**

The Authority shall analyze the submitted application and supporting data and report to the applicant the Authority's recommendation and/or findings. This report shall be within 30 days of the receipt of the application.

#### **7.2.3 Form E-A APPLICATION FOR CONSTRUCTION OF PUBLIC SEWER AND/OR WATER SYSTEMS FOR A RESIDENTIAL, COMMERCIAL OR INDUSTRIAL UNIT INTO EXISTING MMUA SYSTEM (No Main Extension)**

This application and supporting data specifying the engineering details of the proposed project will be analyzed for compliance with Authority engineering standards including provisions for orderly growth. The final condition of approval will be a mutual agreement between the applicant and the Authority regarding the terms and conditions for providing water and sewer service. If applicable, the Superintendent may direct the applicant to submit a Form A Application to the

Authority should the project warrant the Authority Engineer's review. The Engineer shall issue a report within 30 days of the receipt of the application.

#### **7.2.3.1 Fees**

Refer to Application

#### **7.2.3.2 Action by the Authority**

The Authority will review the application and supporting data. If it is determined that it is feasible to extend service and that the plans are in compliance with Authority Rates, Rules and Regulations, the applicant will be notified of the Authority approval and the connection fee. Upon receipt of the fee, the sewer and water permits will be issued to the applicant and to the Building Inspector. Form D must be submitted for release of escrow funds.

#### **7.2.4 Form C Application for construction of public sewer and/or water system See Section 6.5**

#### **7.2.5 Form D Application for any of the following see Section 6.6**

- A. Final Approval of System
- B. Title transfer of public sewer and/or water systems
- C. Acceptance of Change of Use: Residential, Commercial, Industrial
- D. When applicable sign off on Operating Permit
- E. Release Escrow

### **7.3 Prohibited Wastes**

No person or legal entity shall discharge or cause to be discharged or infiltrate to any public or private sewer connected to the Authority's system or Gloucester County Utilities Authority System, the following:

- a). Any liquid having a temperature higher than 150 degrees Fahrenheit (F) [65 degrees Centigrade (C)] or heat in such amounts which will inhibit biological activity in the POTW resulting in interference, but in no case heat in such quantities that the temperature at the POTW Treatment Plant exceeds 40 degrees Centigrade (104 degrees Fahrenheit) unless the State, upon request of the GCUA, approves an alternate limit.
- b). Any wastes from septic tanks cesspools, holding tanks, cesspools, holding tanks or other such sources of domestic wastewater directly into the Authority's system, except when discharged at permitted location and in

accordance with the GCUA Septage Permit System. Any wastewater containing fats, wax, grease, or oils, whether emulsified or not, in excess of 100 mg/L or containing substances which may solidify or become viscous at temperatures between 32 degrees Fahrenheit and 150 degrees Fahrenheit (0 degrees Centigrade and 65 degrees Centigrade).

- c). Any water or wastes that contain hydrogen sulfide in sufficient quantity to cause damage or excessive odor within the Authority system.
- d). Any residue from petroleum storage, refining or processing fuel or lubrication oil, gasoline, antifreeze, naphtha, benzene or other explosive or inflammable liquids, solids, or gases in such concentrations which would cause or potentially cause an explosive, flammable, or other hazardous condition.
- e). Any substance that may:
  - 1. Cause interference with the metering of wastewater.
  - 2. Pass through to the receiving waters without being effectively treated during the wastewater treatment processes at Gloucester County Utilities Authority's plant.
- f). Any discharge into public sewers of solid or viscous substances in amounts which will cause obstruction to the flow, including but not limited to: animal guts or tissue, diseased human organs or tissue fluid, paunch manure, bones, hair, hides or fleshing, entrails, whole blood, feathers, ashes, cinders, sand, spent lime, stone or marble dust, molds, glass, straw, wood shavings, grass clippings, rags, spent grains, spent hops, waste paper, wood, plastic, tar, asphalt residue, residues from refining or processing of fuel or lubricating oil and similar substances.
- g). Any domestic, commercial or industrial sludges resulting from the treatment or pretreatment of any aqueous stream, be it wastewater or not.
- h). Any pollutant that will cause corrosive damage or hazard to structures, equipment, or personnel of the wastewater facilities, but in no case discharges having a Ph lower than 6.0 Standard Units or greater than 9.0 Standard Units.
- i). Any garbage that has not been properly shredded to a degree that all particles can be carried freely under the flow conditions normally prevailing in public sewers. Particles greater than 1/2 inch in any dimension are prohibited.

- j). Any wastewater which constitutes a rate of discharge sufficient to be classified as a "slug discharge" or containing such concentrations or quantities of pollutants that would cause an interference to the Authority's system or GCUA wastewater treatment system.
- k). Any water or wastes containing toxic pollutants or other pollutants in sufficient quantity and/or concentration to cause injury, damage or hazard to the public, or to Authority or GCUA personnel, structures or equipment by contact with the wastewater treatment system or any portion of the liquid or solids treatment or handling processes, or that will pass through the wastewater treatment system in such condition that it will not achieve State, Federal, or other existing requirements for the effluent or for the receiving waters.
- l). Any wastewater containing any liquids, solids or gases which by reason of their nature or quantity are, or may be, sufficient either alone or by interaction with other substances to create any explosive, flammable or combustible, or toxic atmosphere in any part of the Authority's system or GCUA wastewater treatment system. At no time shall two successive readings on an explosive hazard meter, at the point of discharge into the sewer system, be more than five percent (5%) nor any single reading over ten percent (10%) of the Lower Explosive Limit (L.E.L.) of the meter.
- m). Any radioactive waste or isotope of such half-life or concentration as to be in excess of that permitted by appropriate regulatory agencies having control over their use or in such quantity as to cause damage or hazard to structure, equipment, and personnel of the Authority.
- n). Any waste containing noxious or malodorous solids, liquids or gases, which either alone or by interaction with other wastes, are capable of creating a public nuisance or hazard to life or are or may be sufficient to prevent entry into a sewer for its maintenance and repair.
- o). Any material which exerts or causes:
  1. Unusual concentrations of inert, suspended solids (such as, but not limited to: Fuller's earth, lime slurries and lime residue) or of dissolved solids (such as, but not limited to sodium chloride and sodium sulfate).
  2. Excessive discoloration (such as, but not limited to, dye solutions and vegetable tanning solution), which cannot be removed by the wastewater treatment works.
  3. Unusual BOD, COD, or chlorine demand requirements in such quantities as to constitute an unacceptable load on the wastewater treatment plant.
  4. Any unusual concentration or flow of any given constituent which for any period

of duration longer than 15 minutes exceeds more than five (5) times the average 24-hour concentration flow rates during normal operations.

- p). Any wastewater, which, due to its nature, reduces the respiration rate of GCUA plant microorganisms by 25% or more when tested in accordance with Authority protocol.
- q). Any wastewater which, by reason of its nature, exceeds the Authority's base line values for MTX 5 minute or MTX 15 minute when tested in accordance with Authority protocol.
- r). Floor drains from commercial and industrial facilities shall not be directly connected to the sewer system without written approval from the Authority.
- s). Any wastewater that violates Federal, State or Gloucester County Utilities Authority requirements and limitations or those stated in these Rules and Regulations.
- t). Dilution of any wastewater discharge for satisfying parameter limitation requirements shall be considered a violation of these Rules and Regulations.
- u). Any wastewater discharge, either directly or indirectly, into the Authority system, which is in violation of the User's Industrial Discharge Permit issued by the GCUA.
- v). Any wastewater from a user in violation of the Gloucester County Utilities Authority's Industrial Discharge Permit Program Rules and Regulations.
- w). Any wastewater discharged, either directly or indirectly, into the Authority's system not in compliance with the New Jersey Clean Water Enforcement Act.

ANY MMUA PERSONNEL DETECTING ANY PROHIBITED DISCHARGE, UNUSUAL ODORS OR GASES WITHIN THE AUTHORITY'S DISTRICT SHALL NOTIFY THE IMMEDIATE SUPERVISOR, FOREMEN, OR DEPARTMENT HEAD **IMMEDIATELY** AFTER THE OCCURRENCE. SUPERVISOR SHALL IMMEDIATELY TELEPHONE THE OPERATIONS SUPERVISOR ON DUTY AT THE G.C.U.A. WASTEWATER TREATMENT PLANT.

**THE NOTIFICATION SHALL INCLUDE:**

- (1) LOCATION OF DISCHARGE
- (2) TYPE OF WASTE DISCHARGED
- (3) CONCENTRATION AND VOLUME

WITHIN FIVE (5) WORKING DAYS FOLLOWING AN ACCIDENTAL OR NON-COMPLYING DISCHARGE, THE USER SHALL SUBMIT TO THE AUTHORITY A DETAILED WRITTEN REPORT DESCRIBING THE DATE, TIME & CAUSE OF THE DISCHARGE, THE QUANTITY AND CHARACTERISTICS OF THE DISCHARGE, AND MEASURES TO BE TAKEN TO PREVENT FUTURE SIMILAR DISCHARGES.

#### 7.4 Grease, Oil, and Sand Separators

When, in the reasonable opinion of the Authority Engineer, grease, oil and sand interceptors or oil re-claimers are required, they shall be provided and maintained at the expense of the owner, in continuously efficient operating condition. Grease and oil interceptors shall be constructed of impervious materials, capable of withstanding abrupt and extreme changes in temperatures. They shall be watertight, substantially constructed and equipped with readily removable access covers. Where deemed necessary, cold-water sprays shall be installed. The design and pertinent data shall be submitted to the Authority for review and approval, prior to construction or installation. Separators must be constructed entirely on the property of the owner.

#### 7.5 Pretreatment

The Authority reserves the right to require pretreatment and/or flow equalization where the chemical or flow characteristics of the proposed industrial wastes, in the opinion of the Authority Engineer, or in the opinion of state or federal agencies, make such pretreatment or flow equalization desirable or mandatory. Some of the characteristics, which may indicate pretreatment, are listed below:

- a). Five (5) day B.O.D. in excess of G.C.U.A. maximum limits
- b). Suspended solids in excess of G.C.U.A. maximum limits
- c). Quantities of flow, concentration, or both which constitute a "slug" as defined herein.
- d). Presence of arsenic, barium, cadmium, chloride, chromium, copper cyanide, fluoride, iron, lead, magnesium, manganese, nickel, nitrate, selenium, sulfate, zinc, or ph values outside the acceptable limits as described in Section 7.3 (f). The following criteria shall apply.

1. The substances listed below shall not exceed the following specified limits:

	<u>Limit Mg/L</u>
Arsenic	0.1
Barium	2.0
Cadmium	0.02
Chromium (hexavalent)	0.10
Copper	0.20

Lead	0.10
Mercury	0.01
Selenium	0.02
Zinc	0.60

2. Persistent pesticides - not to exceed one-hundredth of the TL 50 value at 96 hours as determined by appropriate bioassay. (Persistent pesticides are defined as natural and synthetic materials having a half-life of greater than 96 hours, which are used to control unwanted or noxious animals or plants. They include fungicides, herbicides, insecticides, fumigants, and rodenticides).

- e). Dissolved solids in excess of GCUA maximum limits
- f). Ammonia (NH<sub>3</sub>) in excess of GCUA maximum limits
- g). Phenol in excess of GCUA maximum limits

In such instances where it is agreed that the industrial waste will be received following pretreatment, drawings and specifications shall be submitted for approval of the Authority Engineer showing all pertinent details of the indicator recorder-register type of flowmeter, wastewater sampler and housing to be used, to meter and sample the flow of industrial wastes, and also details of the control manhole to be constructed on the industrial waste connection. The manhole shall be provided with adequate access manhole covers of approved type, through which access shall be possible to Authority personnel at all times. Drawings, specifications, reports, etc., shall be submitted in quadruplicate and shall be prepared and sealed by a Professional Engineer registered in the State of New Jersey.

Where pretreatment and/or flow equalization facilities are required, they shall be provided and continuously maintained in an effectively operating condition at all times, at the expense of the industry.

Each industry connected to the Authority sewer system shall be responsible for maintaining a quality of effluent from their premises, which conforms to the provisions established in their agreement with the Authority. Sampling and analysis shall be done to conform with accepted practice, and in accordance with the current edition of "Standard Methods for the Examination of Water and Wastewater," 13th edition of the American Public Health Association, Washington, D.C., 1971.

The cost of preparing and submitting this data for consideration by the Authority shall be borne by the industry. Likewise, the cost of sampling and analysis to determine compliance with the terms of the agreement shall be borne by the industry, although conducted by the Authority or its duly authorized representative.

## 7.6 Control Manhole

Industries permitted to connect to Authority sewers, even though not initially being required to provide preliminary treatment, may be required to provide a control manhole and/or meter and sampler as described in Section 7.5.

## 7.7 Penalties for Violations and Discontinuance

Any direct or indirect discharger to the Authority's system found to have violated any provisions of these Rules and Regulations by discharging a prohibited material shall be subject to the following penalties:

1. The minimum penalty for a first violation of these prohibitions shall be \$5,000.
2. The maximum penalty for the first or subsequent violations of these prohibitions shall be determined by: the frequency, intensity, and/or magnitude of the discharger; its effects on Authority personnel, facilities, processes and/or operations, and the impacts on Authority's various permit limitations and conditions. This would include the maximum civil and/or criminal penalties proscribed by the Clean Water Enforcement Act.

In the event that any industry fails to conform to these regulations or fails to comply with the terms and conditions of their agreement with the Authority, which failure causes damages of any sort to the Authority or Authority's employees, the Authority shall determine the extent of the damage and bill the industry accordingly. If such bill is not paid within ten (10) calendar days from the date of the bill, legal action may be instituted to enforce collection; or the Authority may resort to termination of the connection after giving twenty-four (24) hours notice.

The Authority reserves the right to cancel the agreement, upon one year's written notice, in the event of repeated failure to comply with the terms of the agreement, or the Rates, Rules and Regulations of the Authority.

## 7.8 Industrial Waste Flow Meter and Sampler

Where an industry provides its own water supply, entirely separate from that supplied by the Authority, or provides from its own sources a portion of the water consumed on the premises, which eventually finds its way into the sewerage system of the Authority. This does not relieve the industry from the requirements to furnish, install and maintain a flow meter of the indicator-register-recorder type, to measure the discharge of industrial wastes, and a wastewater sampler to periodically take and preserve a portion of the wastewater stream, as described in Section 7.5. The flow Meter and wastewater sampler will be approved by the Authority, but supplied by the customer, with the cost of said equipment, and installation to be borne by the industry. All cost of furnishing,

installing and maintaining the industrial waste flow and sampling equipment will be borne by the industry, and shall be readily accessible to Authority personnel. Flow meters must be calibrated and certified annually, and cost is borne by the industry.

**7.9 Industrial Connection Charge**

The following data shall be used to establish the industrial connection charge for Industrial wastewater.

For industrial waste waters not subject to metering and/or sampling see Section 21 for current fees.

The industrial connection charge is based upon the fees as outlined in Section 21.

**7.10 Industrial Service Revisions**

The industrial wastewater parameters and the criteria for industrial waste limits are subject to future revisions or modification as may be required by the New Jersey Department of Environmental Protection, United States Environmental Protection Agency, the Gloucester County Utilities Authority, The Delaware River Basin Commission and/or the Monroe Municipal Utilities Authority.

End of Section

## SECTION 8 - CONNECTIONS AND SERVICE LINES: WATER

### 8.1 Authority Service Line

New connections, as approved by the Authority, to the existing water mains, shall be at the sole expense of the applicant, including taps, fittings, pipe, labor and related materials. In addition, it shall be the responsibility of the applicant to obtain the necessary permits and to restore the sidewalk and/or street paving. The applicant shall pay a connection charge for each connection as stated by the Monroe MUA Rates, Rules and Regulations. Upon inspection and approval of the installation by a representative of the Authority and the Township Plumbing Inspector, the new connection and lateral from the main to and including the curb stop shall become the property of the Authority and shall be maintained by them. The applicant shall be responsible for all maintenance from the curb valve box to the building, including the meter pit.

### 8.2 Size and Kind of Service Line

The Authority reserves the right to determine the size and kind of service line from the main to the curb stop, and from the curb stop or meter pit to the property to be serviced. The curb stop and meter box (McCullough) shall be placed inside the curb line. Mueller corporation (H-15008) and curb stops (H-15209), Type "K" Copper, compression; underground type, shall be used throughout for service up to and including 2 inches in diameter. For larger services, ductile cement lined pipe meeting A.W.W.A. Standards for Class 52 water pipe, shall be used. The pipe from the curb stop and meter pit, to the property, shall be laid in a straight line at right angles to the curb line, within the building limits of the structure to be served, and shall be at least four (4) feet below the surface of the ground, when final grading of the property has been completed.

### 8.3 Separate Trench

No service pipe shall be laid in the same trench with gas pipe, drain sewer pipe, or any other facility of any public service company, nor within three feet of any open excavation, vault, cesspool or septic tank; nor shall the location be in conflict with any sidewalk or driveway or be subject to vehicular traffic. Plans shall be noted as follows: "Services shall not be located in any area such as sidewalks, driveways or be subject to vehicular traffic. All services shall comply with the current Rules and Regulations of the Department of Environmental Protection.

### 8.4 Maintenance by Customer

The customer shall maintain all connections, service lines, meter pits, and fixtures furnished by the applicant in good order, and all valves, meters and appliances furnished and owned by the Authority, and on the property of the customer, shall be protected properly and cared for by the customer. All leaks in the service, meter pit, and any other

pipe and any fixture in or upon the premises must be immediately repaired by the owner or occupant of the premises.

The customer shall be responsible for notifying the Authority of the party engaged by said customer to do any maintenance work on the customer's service line or meter pit prior to work being commenced and said party shall not backfill any trench until the work has been inspected and approved by the Authority's representative. Any work not acceptable shall be immediately removed and replaced by work that is acceptable.

#### **8.5 Authority Not Responsible**

The Authority shall in no event be responsible for maintaining any portion of the service line or meter pit owned by the customer, or for damage done by water escaping there from; or from lines or fixtures on the customers property; and the customer shall at all times comply with applicable regulations with respect thereto, and make changes therein, required by reason of change or grade, relocation of mains or otherwise.

#### **8.6 Renewal of Service Lines**

Where the renewal of the service line from the main to the curb stop, or meter pit, is found to be necessary, the Authority will renew the service in the same location as previously used. If the property owner, or customer, for his own convenience, desires the new service line at some other location, and agrees to pay all expenses of such relocation, in excess of the cost of laying the service line in the same location as previously used, and cutting off and disconnecting the old service line, the Authority will lay the new service line at the location desired.

#### **8.7 Property Supplied by Single Service Line**

A service line from the curb stop, and meter pit, to a property shall not supply more than one property or use, and any such property as described below must be supplied by two or more meters, and that the supply to each such meter has an individual control at or near the curb, via:

- (a) A dwelling house; either detached, or one side of a double house, or a house in a row of houses; provided that a garage, a conservatory and similar structures accessory to the life of one family shall be considered as a portion of the dwelling.
- (b) An industrial, commercial, or manufacturing establishment.
- (c) A building separated from adjacent buildings by a party wall or party walls, and comprising apartments or stores or offices, or any combination thereof.

(d) A detached building comprising apartments or stores or offices, or any combination thereof.

### **8.8 Single Service Line with Two or More Customers**

Where two (2) or more customers are now supplied through a single service line and any violation of the Rates, Rules and Regulations of the Authority occurs with respect to either or any of said customers, it shall be deemed a violation as to all, and unless said violation is corrected after reasonable notice, the Authority may take such action as can be taken for a single customer, except that such action will not be taken until a customer who has not violated the Authority's rules has been given a reasonable opportunity to attach his pipe to a separately controlled service connection. This shall include but not be limited to duplexes where there is one owner and two families. If the property goes to Settlement, the Authority will enforce or mandate the customer to install separate lines before Settlement can take place. (See Section 21 for charges)

### **8.9 Sprinkling System**

All landscaping and/or lawn sprinkler systems proposing to utilize Authority water require approval by the Authority. The Authority may grant approval or authorization for said systems where determined to be practicable, based upon Authority engineering standards and the available capacity of the Authority's water system. All commercial irrigation systems utilizing Authority water must be connected to the Authority's system via a separate, independent line. The Authority reserves the right and sole discretion to approve or disapprove any landscaping and/or lawn sprinkler systems that would tap into or receive water from the Authority.

The water for any new lawn sprinkler system may also be supplied by a private, individual, on-site irrigation well. Prior to the installation and/or use of such a well, a permit must be obtained from the Gloucester County Department of Health and Senior Services.

### **8.10 Discontinuation of Water Service**

Where the property is no longer habitable or no longer qualifies for a Certificate of Occupancy, the property owner may request permission from the Authority for discontinuation of water service. At the owners expense the existing lateral shall be cut and capped and the Authority should be contacted for inspection.

The property owner shall note that if he pays the turn on/off fee and continues to pay the monthly water charge and if water service is desired at some future time, the owner shall not be assessed new service lateral connection fees. However, if the property owner discontinues to pay the monthly water charge and if water service is desired at some future time, the owner shall be assessed new service lateral connection fees.

### **8.11 Connection Permits & Water Service Charges**

The applicant must purchase a water connection permit for each service unit in accordance with these Rates, Rules, and Regulations. Upon acquisition of each connection permit, the applicant shall be responsible for payment of monthly service charges.

### **8.12 Access to Customer Facilities**

The customer shall maintain the landscaping and grading around the meter pit as set forth on the standard Authority detail. The meter pit lid shall be flush with the finished grade of the adjacent lawn and/or landscaped area.

End of Section

## SECTION 9 - CONNECTIONS AND SERVICE LINES: SEWER

### 9.1 Authority Service Line

New connections to existing sewer mains will be at the expense of the applicant, including tapping (if approved by the Authority), fittings, pipe, labor and related materials. Such new connections and laterals will become the property of the Authority to the curb line, except when the sewer main is located in the sidewalk area, and then the Authority's ownership shall extend to the right-of-way. The Authority will maintain such new connections and new laterals from the sewer main to the curb line or property line (depending on the location of the sewer main) after installation, and inspection and approval by a representative of the Authority together with the Township Plumbing Inspector. Applicant will be fully responsible for street permits, excavation and restoration and the complete cost thereof.

### 9.2 Size and Kind of Service Lateral

The Authority reserves the right to determine the size and kind of the service lateral from the main to the vicinity of the curb line, from the vicinity of the curb line to the property to be served, or from the main in the right-of-way, to the property to be served. Laterals of all sizes shall be constructed of polyvinyl chloride pipe SDR 35 or other piping material specifically approved by the Authority. SDR 26 may be required by the Authority or Authority Engineer when necessary. A sketch showing the service lateral installation is included in Section 23. The service lateral from the curb to the property line including the sewer clean-out shall be furnished, installed and maintained by the owner of the property. A size 4" lateral shall be laid at a minimum grade of 1/4" per foot and in a straight line from the point of connection to the main, where the main is in a right-of-way, or from the end of the Authority constructed service lateral, to the structure to be served and where possible shall be at least four (4) feet below the surface of the ground when final grading of the property has been completed. That portion of the service lateral and sewer clean-out installed and maintained by the owner shall be installed in accordance with the Township Plumbing Inspector prior to backfilling the trench. Any construction not approved shall be immediately removed and reconstructed in an approved manner. No flexible joints (i.e. Fernco Couplings) shall be permitted.

### 9.3 Service Lateral Placement

No service lateral shall be laid in the same trench with any gas pipe, water service, or any other facility of any public utility company, nor within three (3) feet of any open excavation, vault, meter pit; nor shall the location be in conflict with any sidewalk or driveway or subject to any vehicular traffic. Plans shall be noted: "Sanitary laterals shall not be located in any area such as sidewalks, driveways, or be subject to vehicular traffic."

\* All laterals shall be installed within the limits of the customer's property and be minimum of three (3) feet from any property line(s).

\*If service lateral should fall within sidewalk or driveway area, a 3'x 3' break away pad and traffic protector box shall be installed around lateral.

#### **9.4 Elevation of Sanitary Fixtures**

Under no circumstances shall any new sanitary fixtures be installed in a building at an elevation lower than the front curb elevation or street centerline elevation whichever is higher unless special precautions are incorporated into the new fixture installation to prevent surcharging of the new fixture from the sanitary sewer main because of high flows or a blockage. Prior to installation of any fixture which may be lower than the elevation heretofore specified, the owner shall obtain the approval of the Township Plumbing Inspector on the type of precautions that will be taken to eliminate the potential flooding of premises with sewage. In the event a fixture is found to be installed at any point lower than heretofore specified, the Authority may revoke the sewer connection permit or discontinue service until the fixture is removed or positive control measures are instituted to eliminate any potential surcharging of the building with sewage.

#### **9.5 Maintenance by Customer**

All connections, service laterals, sewer clean-outs and fixtures furnished by the customer, shall be maintained by him in good order, and all piping and connections furnished and owned by the Authority and on the property of the customer, shall be protected properly and cared for by the customer. All leaks in the service lateral or any other pipe or fixture in or upon the premises served, must be repaired immediately by the owner or occupant of the premises. The customer shall be responsible for notifying the Authority of the party engaged by said customer to do any maintenance work in the customer's service lateral, prior to work being commenced, and said party shall not backfill any trench until the work has been inspected and approved by the Authority's representative. Any work not acceptable shall be immediately removed and replaced by work which is acceptable to the Authority.

#### **9.6 Responsibility of Authority**

The Authority shall in no way be responsible for maintaining any portion of the service lateral owned by the customer, or for damage done by sewage escaping therefrom; or for lines or fixtures on the customer's property; and the customer shall at all times comply with applicable municipal regulations with respect thereto, and make changes therein, required by reason of changes of grade, relocation of mains or otherwise.

### 9.7 Renewal of Service Lateral

Where the renewal of the service lateral from the main to the curb is found to be necessary, the Authority will renew the service in the location as previously used. If the property owner or customer, for his own convenience, desires the new service lateral at some other location, and agrees to pay all expenses of such relocation in excess of the cost of laying the service lateral in the same location as previously used, and cutting and disconnecting the old service lateral, the Authority will lay the new service lateral at the location desired.

### 9.8 Prohibited Connections

Under no circumstances will any of the following be connected to the sanitary sewers, either directly or indirectly:

- (a) Sump pump under drains
- (b) Floor drain, area drain or yard drain, or drain from swimming pools
- (c) Rain conductor or down spout
- (d) Grease pit
- (e) Air conditioning equipment, except condensate which will be permitted under conditions approved by the Authority
- (f) Storm water inlets or catch basins
- (g) Drains from pieces of equipment or manufacturing process, except when specifically authorized under the provisions of these Rates, Rules and Regulations.

### 9.9 Special Connections

Service laterals to public buildings, churches, apartment houses, commercial establishments, and industrial establishments, shall be installed to conform to detailed plans and specifications approved by the Authority Engineer.

### 9.10 Special Precautions in Wet Ground

Where ground water is normally above the invert elevation of the service lateral, SDR 35 PVC pipe shall be used in construction of the size 4" service laterals. Where the trench bottom is soft and yielding, the Authority Engineer reserves the right to require that the service be ductile iron pipe laid in partial or total concrete encasements. Junctions of two different types of pipe may, at the option of the Authority Engineer, be required to be encased in concrete of mix determined by the Authority Engineer.

### **9.11 Property Served by Single Service Lateral**

A service lateral from the vicinity of the curb, or the main in a right-of-way to a property, shall not serve more than one property or tenant or use, each of which, for billing purposes, shall be considered as being one customer account.

### **9.12 Single Service Lateral with Two or More Customers**

Where two or more customers are now served through a single service lateral, any violation of the Rates, Rules and Regulations of the Authority, with respect to either or any of said customers, shall be deemed a violation as to all, and unless said violation is corrected after reasonable notice, the Authority may take such action as may be taken for a single customer, except that such action will not be taken until a customer who has not violated the Authority's Rates, Rules and Regulations has been given a reasonable opportunity to connect his pipe to a separately controlled service lateral.

### **9.13 Policy on Blockage**

While the Authority has no responsibility beyond the curb line, it will, as a public service, clear the curb clean-out at the request of the customer on his initial request. The Authority will also verify that the portion of the service line between the curb and main is clear and, when necessary, take action to clear that section of the line.

**9.13.1** If the customer requests that the Authority open the street to clear a blockage and the result of the excavation clearly indicates that the blockage is on the service line belonging to the customer, the customer will be charged for the cost of the excavation and service.

**9.13.2.** If the customer has no curb clean-out, any blockage in the service line between the dwelling and the main shall be considered the responsibility of the customer.

### **9.14 Policy on Missing or Damaged Curb Clean-out Caps**

When the Authority inspection indicates that a sewer cap is missing or damaged, the customer will be notified that the cap must be repaired or replaced within seven (7) days. After that time period, the Authority will replace or repair the clean-out cap and the customer will be charged for parts and labor. See Section 21, 21.8 for pricing.

### **9.15 Unauthorized Connection**

No unauthorized person(s) shall uncover, make any connection with or opening into, use, alter, or disturb any public sewer, service lateral or appurtenance thereof without first obtaining a written permit from the Authority.

#### **9.16 Construction Safeguards**

All excavations for service lateral installation shall be adequately guarded with barricades and lights so as to protect the public from hazard. Streets, sidewalks, parkways, and other public property disturbed in the course of the work shall be restored in a manner satisfactory to the Township of Monroe.

#### **9.17 Discontinuation of Sewer Service**

Where the property is no longer habitable or no longer qualifies for a Certificate of Occupancy, the property owner may request permission from the Authority for discontinuation of sewer service. If granted, the existing lateral shall be cut and capped by the owner; the Authority shall witness the capping of the service.

The property owner should note that if he continues to pay the monthly sewer charge and if sewer service is desired at some future time, the owner shall not be assessed new service lateral connection fees. However, if the property owner discontinues paying the monthly sewer charge and if sewer service is desired at some future time, the owner shall be assessed new service lateral connection fees.

#### **9.18 Policy on New Authority Pump Stations**

Applicants should only propose new pump stations for subdivisions or sites when gravity sewer cannot be extended to service the new development. No new force mains are to be installed in sections where gravity sewer mains can be extended from the existing gravity sewer system to service the project.

It is the policy of the Authority, that should a pump station be required to service the development and the Authority consents to accept the pump station, that the new facility must be complete and built in accordance with the approved plans and specifications before the first meter is installed, the applicant must submit the Form D applications for title transfer of the pump station facility and the Authority must accept this transfer by formal resolution. The applicant must follow all necessary requirements, as outlined in Section 6.6 Application for Acceptance - Form D.

End of Section

## SECTION 10 - WATER METERS

### 10.1 All Water Services Shall be Metered

Each water service from curb stop, or meter pit, to a property shall be metered. The Authority reserves the right to determine the size and location of the meter.

### 10.2 Service Fee

All water meters will be furnished by the Authority upon payment of a service fee equivalent to the cost of the meter and yoke and shall be installed by Authority personnel, and will remain the property of, and under the control of, the Authority and will be accessible.

### 10.3 Location

After the applicant has provided space for the meter, which will be readily accessible and will provide proper protection for the meter and has had the plumbing arranged to receive the meter at a convenient point approved by the Authority and so positioned as to meter and control the entire supply, the Authority will have the meter set. In cases where the Authority decides not to place the meter within a building, a Mueller thermal-coil meter pit with a composite lid shall be installed in the area between the curb and sidewalk.

### 10.4 Meter Pit

The meter pit shall be a Mueller thermal-coil meter pit part number 330CS1842LSBSN. All Mueller meter pits shall be 1" unless approved by the Authority. Any reduction in the pipe size shall occur after the meter pit. The meter pit shall have a composite plastic lid part number 311955. The meter pit shall have an insulated pad for inside the pit part number 790153.

The inlet and outlet brass connections shall pass through the pit wall and shall be locked in place by brass hex nuts on straight external iron pipe threads. The other end of the inlet connection shall be attached to Polybutylene Tubing. The tubing shall have a pressure rating of 250 psig and shall be crimped in place in the brass connector with an internal stiffener used to support the tubing from the inside. The other end of the Polybutylene Tubing coil shall be attached in a similar manner to another brass connector. The Polybutylene Tubing shall be coiled between the inlet connector and the connector at the base of a movable platform. The connector at the base of the platform shall be attached to an inlet angled valve with female tapered iron pipe threads on the inlet and with a meter coupling outlet. The valve shall be lockwing. An angled dual check valve with independent acting checks shall be downstream of the water meter. The check valve shall have a meter coupling inlet and an internal tapered iron pipe thread

outlet and shall be contained inside the pit. Both the inlet valve and the outlet valve (or fittings) shall be connected to and movable on the platform to increase or decrease the gap where the meter is placed. The platform in its normal position shall be supported by a circular strip attached to the pit wall. The strip shall be made from P.V.C. material. The platform shall be designed so it can be raised to the top of the box without disconnecting any of the piping. In the raised position, it shall be capable of being set atop the lock lug surfaces at the top of the pit, thereby allowing the meter to be removed or otherwise worked on at ground level. All brass material used in contact with the water must have a minimum copper content of 80% and a maximum zinc content of 10%.

When required, the pit shall have a metal bottom mechanically attached to the pit wall.

#### **10.5 Inside Meters/Valves Required**

A ball valve shall be placed by the customer both before and after the meter when the meter is not installed in an outside meter pit. A suitable and approved check valve shall be placed by the customer, between the shut off valve and meter. When a check valve is installed, a safety valve should be inserted at some convenient point in the house piping, to relieve excess pressure due to heating water.

#### **10.6 Responsibility for Damage**

Meters will be maintained by the Authority so far as ordinary wear and tear are concerned; but damage resulting from freezing, hot water, or external causes due to the negligence of the customer, shall be paid for by the customer.

#### **10.7 Cost of Reinstallation**

The customer shall pay a charge for the installation or changing of a meter when removed because of damage in any way due to the negligence of the customer. The charges shall be as listed in Section 21, Schedule 4.

#### **10.8 Minimum Charge**

Each meter is installed subjected to a fixed minimum monthly charge in accordance with the adopted rate schedule, for which certain quantities of water will be furnished without additional charge. Such minimum charge shall be non-abatable for nonusers of water, and noncumulative against subsequent consumption. In the case of fractional period bills, covering a month, minimum charges and allowance shall be prorated.

#### **10.9 Authority to be Notified When Meter Not Working**

The customer shall immediately notify the Authority of damage to or non-working of the meter, as soon as known by the customer.

#### **10.10 Registration Conclusive**

The quantity recorded by the meter shall be conclusive on both the customer and the Authority, except when the meter has been found to be registered inaccurately or has ceased to register. In such cases, the quantity may be determined by the average registration of the meter when in proper working order.

#### **10.11 Disputed Account**

In the event of a disputed account involving the accuracy of a meter, such meter will be tested upon the request of the customer, in conformity with the provisions of the Rates, Rules and Regulations. If when so tested, the meter is found to have an error in registration of four percent or more, the bills will be increased or decreased accordingly.

#### **10.12 Request Test**

When a meter is removed, after installation, at the request of the homeowner, for testing, the following regulations shall apply:

The Authority shall, upon homeowner's written request, and in the presence of the homeowner, make a test of the accuracy of the meter. If the meter so tested, shall be found to be accurate within the limits specified in Section 10.10, a fee determined from Section 21, Schedule 4, shall be paid to the Authority by the homeowner, but, if not so found, then the cost thereof shall be borne by the Authority. When making such request, the customer shall agree to the basis of payment herein specified. A report of such test shall be made to the customer and a complete record of such test shall be kept by the Authority. The amount of the fee is listed in Section 21 Schedule 4.

#### **10.13 Turn Off Without Authority**

Neither the customer nor any plumber or other persons shall turn the water on or off at any corporation stop, curb stop, or meter valve; or disconnect or remove the meter, or permit its disconnection or removal, or tamper with the meter pit without the written consent of the Authority.

#### **10.14 Tampering with Water Meter**

Where the meter has been inspected and found to have been removed, damaged or tampered with, the customer will be notified by letter that a service charge will be required to repair the meter. If the customer refuses entry to the premises, service can be discontinued, and an additional fee will be charged to restore the service. See Section 21, 21.8.

End of Section

## SECTION 11 - DAMAGE TO SYSTEM

### 11.1 Penalty

No person(s) shall maliciously, willfully, or negligently break, damage, destroy, uncover, deface, or tamper with any structure, appurtenance or equipment which is part of the Monroe Municipal Utilities Authority wastewater or water facilities. Any person(s) violating this provision shall be subject to immediate arrest and prosecution for the charge of disorderly conduct.

End of Section

## SECTION 12 - MINIMUM TECHNICAL DESIGN STANDARDS - SEWERAGE

### 12.1 Separate Sewer Required

The Authority will approve plans for proposed new sewerage systems or extensions only when designated upon the separate system plan, in which all water from roofs, cellars, streets, and other areas is to be excluded.

### 12.2 Summary of Information Required

- (a) A general map of the entire project including a key map showing the location of the project with respect to municipal boundaries.
- (b) An area map covering probable future tributary areas for sewer systems projects.
- (c) Plans and profiles of all proposed sewers.
- (d) Specifications for all proposed construction.
- (e) A report upon the proposed system by the designing or consulting engineer (See Section 12.7)
- (f) Soil logs indicating the elevation of the seasonal high water table.

### 12.3 Preparation of Sewer Maps and Plans

#### 12.3.1 General

Plans shall be drawn to standard scales and shall show the entire area of the project. The name of the Engineer and his seal shall be shown. In case there is more than one sheet, all shall be bound together and an index map supplied, showing by number, the area and districts covered by the various sheets. A general plan shall accompany each application for a new system or any extension or modification of any existing sewer system. Plans should not generally exceed 30" x 42" in size.

Plans shall show district boundaries, all existing and proposed streets, and the surface elevations at all street intersections where sewer lines are proposed. Existing structures, both above and below the ground, will be shown.

Plans shall show clearly the location of all existing and proposed sewers, and the location of existing and proposed pump stations, force mains, North arrow based on the New Jersey State Plane Coordinate System, the boundary lines, title, date and scale.

### **12.3.2 Symbols**

Sewers to be built at present and sewers to be constructed later shall be shown by standard conventions. Existing sanitary sewers shall be shown by special designations. All topographical symbols and conventions used are to be the same as those of the United States Geological Survey.

### **12.3.3 Elevations**

Elevations of the surfaces of streets shall be placed outside the street lines opposite their respective positions in the street. The elevations of sewer inverts shall be shown at street intersections, ends of lines, and wherever a change of grade occurs. The elevation of sewers shall be written close to the point to which they refer, parallel with the sewer lines and between the street lines. The elevations of the surfaces shall be shown to the nearest 0.1 foot; those of the sewer inverts to the nearest 0.01 foot. All elevations will be referenced to the standard datum. Two benchmarks shall be permanently established on the nearest existing road at the site and shown prominently on the plans. The benchmark elevations shall be based upon the North American Vertical Datum of 1988 (NAVD88). Horizontal coordinates of the benchmarks shall be based on the New Jersey State Plane Coordinate System (North American Datum of 1983 – NAD83).

### **12.3.4 Distances, Grades, Sizes, and, Types**

The horizontal distance and stationing between manholes, grades in percent and sewer sizes and types shall be shown on all proposed sewer lines. Arrows shall be drawn to indicate the direction of flow.

### **12.3.5 Sewer Appurtenances**

All sewer appurtenances, such as manholes, siphons, pumping stations, etc., shall be designated on the plans by suitable symbols and referenced by a legend near the title.

## **12.4 Profiles**

Profiles shall indicate all manholes (with manhole numbers, rim and invert elevations), pumping stations, etc., and in the case of stream crossings, elevations of stream beds, normal flow lines and the type of pipe. Figures showing the sizes and gradients of sewers; surface elevations, sewer inverts, etc., shall be shown at or between each manhole.

All existing and proposed utilities such as; water mains, storm sewers, gas mains, telephone and electric lines shall be shown in relation to existing and proposed sanitary sewer lines.

Seasonal high water table shall be shown on the profiles.

## 12.5 Standard Details of Construction

Detail drawings of all sewer appurtenances, such as manholes, pumping stations, etc., shall accompany the general sewer plans. All detail drawings shall be consistent with the Monroe MUA standard details.

## 12.6 Specifications

Specifications directly applicable to the sanitary engineering (including hydraulic features) of the proposed project shall accompany all plans.

## 12.7 The Engineer's Report

A report by the designing or consulting engineer shall accompany all plans and specifications. The report shall include or be accompanied by a signed and sealed by a Professional Engineer currently licensed in the State of New Jersey and a statement by the engineer averring that the proposed project complies with all of the Rules and Regulations of the Department of Environmental Protection; provided, however, if there are any exceptions thereto, the averment of compliance shall include a listing of such exceptions and an explanation of the reasons thereof. The report itself shall give all pertinent data upon which the design is based, including, where applicable and appropriate, the following:

### 12.7.1 Required Information Concerning Sewer System

- (a) The nature and extent of the area, which it is proposed to include within the present system of sewerage, and of the area, which it is planned, shall drain ultimately into the system, including sections not within the boundaries of the affected municipality.
- (b) The number of houses and the population to be served both present and estimated, for at least twenty-five (25) years hence, with computations and curves.
- (c) The estimated average daily flow of sewage, with supporting data.
- (d) The total and per capita water consumption of the district to be served at the present time, if available.
- (e) The allowance made for infiltration in the sewers.
- (f) The estimated daily flow of sewage, including infiltration.

- (g) The character of the sewage (whether domestic or industrial wastes or process waters, and in case of the latter, the nature and approximate quantity of the same stated in specific terms); also a breakdown of all quantities.
- (h) That portion of the system to be built at the present time.
- (i) The minimum grades of sewers for each size used.
- (j) Logs of test borings and ground water elevations will be shown.

**12.8 Capacity and Design Period**

All sanitary sewers, including outfalls, shall be designed to carry at least twice the estimated average design flow when flowing half full. In the case of large interceptor sewer systems, consideration may be given to modified designs.

The design period for the estimated flow shall be at least twenty-five (25) years; longer periods may be required for major projects.

For sewers other than circular in cross section, the data to be submitted shall include the geometrical shape, dimensions and hydraulic characteristics of the proposed sewer.

**12.9 Materials, Minimum Grades, and Velocity of Flow**

- (a) All sewers shall be constructed of materials acceptable to the Authority for the purposes and conditions they are intended to serve.
- (b) Sewers shall be designed with such hydraulic slope as will give a mean velocity of not less than two (2) feet per second when flowing full or half full, based on Kutter's or Manning's formula with  $n = 0.010$  or  $n = 0.013$ . The fall in feet per 100 ft. of sewer shall be not less than the following:

**Fall In Feet per 100 Feet of Sewer**

Pipe Diameter	Recommended Minimum Allowable ( $n = 0.010$ )	Recommended Minimum Allowable ( $n = 0.013$ )
8"	0.300	0.400
10"	0.200	0.290
12"	0.150	0.220
14"	0.120	0.170
15"	0.100	0.160
16"	0.090	0.140
18"	0.075	0.120
20"	0.065	0.100
21"	0.060	0.095
24"	0.050	0.080

27"	0.042	0.067
30"	0.035	0.058
36"	0.028	0.046

(c) Grades producing velocities in excess of ten feet (10') per second are not recommended.

(d) The minimum size of sewer mains shall be eight inches (8"). The pipe shall meet the requirements of the schedule below based upon the depth of the sewer pipe. The depth shall be measured from the pipe invert to the finished surface above the pipe. Pipe shall have integral wall bell and spigot joints.

- i. Depth of pipe up to ten (10) feet ( $d \leq 10'$ ): Pipe shall be polyvinyl chloride (PVC) sewer pipe and fittings meeting the requirements of ASTM D-3034 (SDR 35), Type PSM.
- ii. Depth of pipe over ten feet and up to twenty feet ( $10' \leq d \leq 20'$ ): Pipe shall be polyvinyl chloride (PVC) sewer pipe and fittings meeting the requirements of ASTM D-3034 (SDR 26), Type PSM.
- iii. Depth of pipe greater than twenty feet ( $d > 20'$ ): Pipe shall be Class 52 ductile iron pipe with "Protecto 401" ceramic epoxy lining or approved equal. Alternatively, pipe may be PVC pressure pipe conforming to AWWA C900 (DR 18).

(e) Curved sewers will not be permitted.

(f) Sewers crossing streams or to be located within ten (10) feet of a stream embankment or otherwise where unusual strength is indicated, shall be of steel, ductile iron or other suitable material and shall be properly protected.

(g) Sewers and water mains generally shall be separated, a distance of at least 10 feet horizontally. If such lateral separation is not possible, the pipes shall be in separate trenches with the sewer at least 18" below the bottom of the water main; or such other separation as approved by the Authority shall be made. In general, the vertical separation at a crossing of sewer and water line shall be at least 18". Where this is not possible, the sewer shall be constructed of ductile iron pipe using mechanical or slip-on joints, for a distance of at least 10 feet on either side of the crossing or other suitable protection shall be provided.

(h) Sewer and Water mains shall be located within the cartway of the roadway a minimum of three (3) feet from the face of curb, or within easements specifically dedicated to the Utilities Authority. Any other locations will be subject to the discretion of the Utilities Authority.

(i) Any sewer within 100' of water supply well or a below-grade reservoir shall be of steel, ductile iron or other suitable material; shall be properly protected, of completely watertight construction, and shall be tested for watertightness after installation.

(j) The minimum size of sewer laterals shall be 4 inches. The pipe shall be polyvinyl chloride sewer pipe and fittings shall meet with the requirements of ASTM specifications D3034-21 (SDR 26), type PSM. Gaskets shall meet with the requirements of ASTM F477-14 (2021). Couplings shall be Fluid-Tite by CertainTeed, Ring Tite by Johns-Manville, or approved equal. Joints shall be tested in accordance with ASTM D3212-21. Pipe shall have integral wall bell and spigot joints. Minimum "pipe stiffness" at five-percent (5%) deflection shall be 115 lbs. when tested in accordance with ASTM D2412-21.

(k) When grades less than those specified above are proposed, an explanation for the use of such grades shall be included in the engineer's report; and said explanation shall be included in the averment called for under 12.7.

#### **12.10 Joints**

Joints in sewer lines constructed of polyvinyl chloride shall be Fluid-Tite by CertainTeed, Ring-Tite by Johns-Manville, or approved equal. Joints shall be tested in accordance with ASTM D3212-21.

Gaskets shall meet with the requirements of ASTM F477-14(21).

#### **12.11 Manholes**

Manholes shall be provided at the ends of each sewer line and at intersections and at all changes in grade, size, or alignment.

Distances between manholes shall not exceed 400 feet for sewers. A drop pipe shall be provided for sewers entering manholes above the manhole invert wherever the difference in elevation is two (2) feet or more.

No manholes or connections on a sanitary sewer system will be permitted within 100 feet of a water supply well or a below-grade reservoir.

Manholes sections shall be precast concrete constructed in accordance with ASTM C478/C478M-22.

Adequate provisions shall be made for ventilation.

Manholes receiving effluent from sanitary sewer force mains shall be lined with a “Dura Plate 100” PVC liner as manufactured by Atlantic Concrete or approved equal.

## **12.12 Pumping Stations**

### **12.12.1 General**

(a) Raw sewage shall be screened before pumping unless special pumping equipment approved by the Authority and the Department of Environmental Protection is used. Comminutors may be required in lieu of screens.

(b) Two (2) pumping stations discharging into a common force main is not permitted. A design waiver must be granted to permit this condition.

(c) A permanent auxiliary source of power shall be provided for electrically driven pumps. In the event the pumps rated horsepower is 10 or less, or the flow is 100 gpm or less, the applicant may apply to the Authority for an alternate source of power. However, the Authority may require a permanent generator to be located at any pump station. The auxiliary power source shall be adequate to start the second pump within the duty pump operating (stagger start) and all auxiliary equipment simultaneously. Should the permanent auxiliary generator not be required, the station shall be provided with generator plug model # JRS 634 H Russell Stoll A-600 VAC-250 V.

The developer shall be fully responsible for ensuring the generator has been designed to meet all operational requirements of the Authority. The design must account for all electrical loading at the facility requiring permanent auxiliary power. Neither the Authority nor the Authority Engineer shall assume any responsibility for the design or performance of the auxiliary generator. The auxiliary generator shall be subjected to testing in accordance with the Authority policies and procedures and the test results must be deemed satisfactory by the Authority and Authority Engineer as a prerequisite to acceptance under the Authority Form D application. The generator shall be fully operational in accordance with the manufacturer’s standard operations manual, without the need for auxiliary back-up devices of any kind. The generator shall experience no more than a 15% voltage drop during motor starts.

(d) Automatic visual and sound alarms, operating independently of the station power, shall be installed to give warning of high water, power failure, or breakdown. The alarm system shall be a RACO, Model CB-4 "Chatterbox" automatic dialing remote monitoring system to a location determined by the Authority Superintendent.

(e) Pumping stations shall not be subject to flooding and must be accessible by motor vehicles. Pump stations shall be provided with an all-weather plowable surface capable of supporting a fully-loaded jet-vac truck with a gross vehicle weight (GVW) of 85,000 pounds under all weather conditions.

(f) Adequate light and ventilation shall be provided at all pumping stations. Where operational or maintenance duties are required in enclosed areas or pits, forced ventilation by suitable means shall be provided with sufficient capacity to induce at least 12 air changes per hour. Explosion proof equipment shall be utilized in wet wells and other similar areas.

(g) Adequate fresh-water facilities (yard hydrant) shall be provided to permit routine wash down and cleaning operations at all pumping stations. The yard hydrant shall be a cast iron non-freeze post type with aluminum housing and galvanized casing, all brass mechanism, brass valve hydrant head, and wheel operating handle, Murdock M-175 or equal. Where a domestic water service connection is provided to a pumping station, the water supply shall be properly protected as described below. No connections between fresh-water and sewage pumps or pipes shall be permitted.

(i) Where a domestic water service connection is provided to a pumping station, the water supply shall be protected by an approved backflow prevention device acceptable to the N.J.D.E.P.

Air gap separation shall be used to prevent cross connections within the dry well and shall mean a physical break between a supply pipe and a receiving vessel. The air gap shall be at least double the diameter of the supply pipe, measured vertically above the top rim of the vessel, in no case less than one inch. All hose connections from the domestic water supply shall be protected with an approved backflow prevention device acceptable to the N.J.D.E.P.

(ii) Taps supplying non-potable water shall be clearly labeled "Unfit for Drinking".

(h) Complete set of manufacturer's parts lists, instructions, maintenance manuals, and special tools are to be turned over to the Authority.

(i) The standard Authority pump station is a submerged-pump, wet well station. All proposed wet well pump stations shall be compatible to the Authority's inventory, which is comprised almost exclusively of Flygt Inc. parts.

(j) Electrical service shall be three-phase current.

(k) Locks and keys will be provided by the contractor to the Authority Superintendent. Four (4) remote operators will be supplied to the Authority for the automatic access gate.

(l) All force mains shall be cement-lined ductile iron pipe (CLDIP) conforming to A.W.W.A. Specifications C150-21 and C151-17 or polyvinyl chloride (PVC) pressure pipe conforming to A.W.W.A. C900-22. Polyethylene pressure pipe conforming to A.W.W.A. C906-07 may be considered on a case-by-case basis.

CLDIP mains shall be Class 52 not exceeding 160 psi unless design conditions require higher strength pipe. Ductile iron pipe shall be coated inside and outside with a bituminous coating. Cement lining shall conform to AWWA C104-22 Joints shall be push-on type and shall be installed in strict conformance with manufacturer's recommendations. For design purposes, head loss calculations for the force main and fittings shall be performed using the Hazen-Williams Equation with a "c" of 110.

PVC force mains shall be DR 25, pressure class 165 psi unless design conditions require higher strength pipe. Joints shall be push-on type and shall be installed in strict conformance with manufacturer's recommendations. For design purposes, head loss calculations for the force main and fittings shall be performed using the Hazen-Williams Equation with a "c" of 150.

Marking tape and tracer wire shall be provided whenever PVC pipe or other non-metallic pipe is installed. The tape shall be of plastic material without integral wires or foil backing. The tape shall be not less than two (2) inches wide and shall have an identifying phrase in black letters repeated at maximum intervals of three (3) feet. The tape shall be of a type specifically manufactured for marking underground utilities. The tape shall be installed during backfilling operations. Tape shall be located two (2) feet below finished grade. The tape shall be centered on the utility line with the identifying phrase on top. The identifying phrase shall be "SEWER LINE BELOW."

Tracer wire shall not be integral to the marking tape. The wire shall be twelve (12) gauge solid copper wire encased in a protective plastic jacket. The wire coating color shall be green. The wire shall be placed above the pipe line and shall be taped to the pipe at twenty-five foot (25-foot) intervals. The wire shall be installed continuously along the full length of the force main. If splicing is necessary, a direct bury splice kit shall be required. All other installation details shall meet the requirements of the Authority.

(m) Pump Station Flow Meter – The Contractor shall provide a flow meter with two (2) programmable alarms, battery backup, digital display, inflow and outflow monitor, pump data, and totals. Flow meter to be Volumeter Model 301 or 302 as directed by the Authority and the Authority Engineer, as manufactured by Marsh-McBirney, Inc., or approved equal.

(n) Gas Detection Apparatus – The Contractor shall furnish gas detection equipment at the pump station for air monitoring and personal protection. The instrument should be designed to meet all federal OSHA confined space safety standards.

The gas detector furnished shall be Impact Gas Detector Part No. 2302B2, as manufactured by Zellweger Analytics, or approved equal.

### **12.12.2 Pumps**

(a) Pumping station capacity should be compatible with the ultimate capacity of the service area sewer. At least two pumps, each designed to handle peak flows for 10 years hence, shall be provided. If more than two pumps are provided, their capacities shall be such that, upon failure of the largest pump, the others will handle such peak flows.

Pumps shall be installed in wet wells and shall operate under a positive suction head. Submersible sewerage pumps with guide rails and special discharge flanges for raw sewage will be approved. A means of flow measurement is required. Shut-off valves and check valves shall be provided on each pump discharge pipes. Special repair tools and accessories required for maintenance shall be provided.

(b) Force main velocities shall not be less than two feet per second at the pumping rate calculated at pumps off level. Properly designed air release valves shall be provided on the high points of the force main and in the valve chamber. Additional isolation valves may be required in the force main should the Authority Engineer determine their necessity for proper maintenance and operation of the system.

(c) Pump size and operating characteristics must meet the approval of the Authority. The developer is fully responsible for a pump station design that is in complete compliance with NJDEP regulations and the operational requirements outlined in the MMUA Rules and Regulations. Neither the MMUA nor the MMUA Engineer shall assume any responsibility for the design or performance of the pump station. The wastewater pumps shall be subjected to testing in accordance with the MMUA policies and procedures and the test results must be deemed satisfactory by the MMUA and MMUA Engineer as a prerequisite to acceptance under the MMUA Form D application.

(d) Both pumps shall have the ability to operate in parallel if flow rate requires.

(e) The pump design selection should be based upon a duty point (aka operating point) that is as close as practicable to the best efficiency point (bep) on the pump performance curve. The Engineer's Report shall include calculations determining the pump station/force main system curve, and the system curve shall be plotted and superimposed over the pump performance curve illustrating the operating point of the pump design selected. The pump selection shall also take into consideration the head required to drain the station to the bottom of the volute.

### **12.12.3 Wet wells**

- (a) Wet wells shall provide adequate ventilation and drainage as well as means of entrance and exit.
- (b) The detention time pump on to pump off of a wet well should not exceed 10 minutes when the flow is at the average dry weather ADR (average daily flow) rate.
- (c) The floor fillets of wet wells shall slope at least 45 degrees toward pump suction to prevent solids accumulation.
- (d) The applicant shall provide a wet well with capacity such that the Authority Maintenance Personnel is provided with a reasonable amount of time (30 min.) to respond to an emergency prior to the level in the wet well equaling that of the influent main. The emergency response time shall be between the high water alarm and the influent pipe invert. The criteria shall be reviewed by the Authority Superintendent and Authority Engineer.
- (e) A davit with winch (electric with manual backup), Thern Commander 2000 5PT20 Stationary Crane, as manufactured by Thern, Inc., shall be provided at the station acceptable to the Authority Engineer and Authority Superintendent for pump station with motors having a pump Hp rating less than 10Hp.

For pump stations with a motor rating at 10 Hp or above a standing jib crane as manufactured by Gorbel, Inc. or approved equal shall be provided. The hoist and crane shall be rated for a minimum of 2.5 times the pump weight but shall not be less than 2 tons. The hoist shall be motorized for travel on the jib crane with a stainless steel chain and chain container capable of holding the entire chain. The chain length shall be capable of reaching the bottom of the wet well plus 5 feet

- (f) A pole-mounted yard light(s) or wet well light or both shall be provided at the station. Additionally, a wet well light (explosion-proof) shall be provided.
- (g) A force main by-pass chamber shall be provided by the applicant. This by-pass shall be of a design acceptable to the Authority Engineer and Authority Superintendent.
- (h) The design of the wet well and arrangement of the pumps and rails, shall be such that when the pumps are pulled, they are easily accessible.
- (i) A minimum of eight-foot (8') diameter wet well of reinforced concrete construction is required. The wet well shall be sized based upon the ultimate flow of the watershed as per the Authority Sanitary Sewer Master Plan. The entire interior of the structure shall be lined with a PVC liner, "Dura Plate 100", as manufactured by Atlantic Concrete, or approved equal.
- (j) Ductile iron pipe shall be used from the last manhole to wet well, with plug valve.

- (k) Permanent ladders constructed of stainless steel and meeting OSHA requirements, shall be installed in the wet well.
- (l) The wet well shall be provided with watertight joints with gaskets and internal and external grout at base slab.
- (m) The concrete base slabs and surface pads are to contain reinforcing bars.
- (n) Access hatches are to be Flygt, with “safe-hatch”, as manufactured by Flygt Corporation, or approved equal.
- (o) All force mains shall have four-foot minimum cover.
- (p) A 110-volt, 20 amp, GFI protected weatherproof duplex receptacle outlet shall be provided at the station. The outlet shall not be located in the control panel, but rather in a separate outdoor and weatherproof enclosure.
- (q) The following appurtenances within the wet well shall be manufactured from stainless steel only, meeting OSHA standards.
  - (i) Ladder and guide rail assembly
  - (ii) Debris basket, rail assembly and cable
  - (iii) Davit cable or chain
- (r) Concrete manholes and plug valves should be constructed at a location in accordance with the current Authority standard details.
- (s) Electric Grinder – A pump station electric grinder (comminutor) assembly shall be provided at the sanitary sewage influent line in the wet well and shall be capable of continuous operation processing wet or dry. The electric grinder shall be “Muffin Monster” Model 30005, as manufactured by JWC Manufacturer, or approved equal.

#### **12.12.4 Controls**

- (a) Equipment Descriptions:
  - (i) Enclosure – The control system shall be housed in a NEMA-4X enclosure suitable for outdoor installations. It shall be manufactured from twelve (12) gauges, Type 316 stainless steel. All hardware including the hinges, latches and padlock provisions shall be stainless steel.

(b) Level Controls:

(i) Liquid Level Indicator/Controller – The wet well level shall be monitored and maintained by a maintenance-free liquid level control system, using a differential pressure transducer to sense liquid levels.

The liquid level indicator/controller shall be Model No. P2DHA intrinsically safe, as manufactured by Magnova (MDI), or approved equal.

There shall be a separate ball float back up system at all required levels. The pressure transducer shall be the primary system with a labeled selector switch. This switch shall be capable of terminating power from the primary system to the back up system for removal for maintenance purposes.

(c) Electrical:

POWER DISTRIBUTION

- A. The panel power distribution shall include all necessary components and be completely wired with stranded copper conductors rated at 90 degrees C. All conductor terminations shall be as recommended by the device manufacturer.
- B. All circuit breakers shall be heavy-duty thermal magnetic or motor circuit protectors similar and equal to “Square D” type FAL.
  - 1. Each motor breaker shall be adequately sized to meet the pump motor operating characteristics and shall have a minimum of 10,000 amps interrupting capacity for 230VAC and 14,000 amps at 480 VAC. The control circuit, the duplex receptacle and any other control breakers shall individually be controlled by heavy duty breakers.
  - 2. Circuit breakers shall be indicating type, providing “On/Off/Trip” positions of the operating handle. When the breaker is tripped automatically, the handle shall assume a middle position indicating “Trip”.
  - 3. Thermal magnetic breakers shall be quick-make and quick-break on manual and automatic operation and have inverse time characteristics secured through the use of bimetallic tripping elements supplemented by a magnetic trip.

4. Breakers shall be designed so that an overload on one pole automatically trips and opens all legs. Field installed handle ties shall not be acceptable.
- C. Motor starters shall be open frame, across the line; NEMA rated with individual overload protection in each leg. Motor starter contact and coil shall be replaceable from the front of the starter without removing from its mounted position.
1. Overload heaters shall be block type, utilizing melting alloy spindles and shall have visual trip indication. Overload shall be sized for the full load amperage draw of the pumps. Adjustable type overloads, definite purpose contactors, fractional size starters and horsepower rated contactors or relays shall not be acceptable.
- D. Control transformers shall be provided to provide the 120 VAC and/or 24VAC for control circuits. Transformers shall be fused on the primary and secondary circuits. The secondaries shall be grounded.
- E. A lightning-transit protector with tell-tale warning lights on each phase to indicate loss of protection on the individual phases shall be provided. The device shall be solid state with a response time of less than 5 nanoseconds withstanding surge capacity of 6500 amperes. Unit shall be instant recovery, long life and have no holdover currents.
- F. A line voltage rated, adjustable phase monitor shall be installed to sense low voltage, loss of power, reversed phasing, and loss of a phase. Control circuit shall de-energize upon sensing any of the faults and shall automatically restore service upon return to normal power.
- G. MiniCAS
1. Furnish and install one Flygt MiniCAS (Mini Control and Status) module to monitor the temperature and leakage detectors installed in each small to medium sized Flygt Model 3085 through 3300 pump or model series 4600 mixer. The MiniCAS shall be capable of monitoring the thermal switches embedded in the stator end coils, the FLS (float switch type) water in the stator housing sensor, and the CLS (capacitive type) water in oil sensor. The MiniCAS shall monitor both the series connected thermal switches and leakage sensor(s) by outputting 12 VDC on a single two wire circuit. When both CLS and FLS leakage sensors are specified, they shall be connected in parallel with each other and then in series with the thermal switches.

2. The MiniCAS circuitry shall operate on the current sensing principle whereby a change in temperature or leakage condition shall change the resistance of the associated sensor and thus alter the current in the sensing circuit. The MiniCAS shall contain two sets of form C dry contacts, one for over temperature and one for leakage. The dry contacts shall change state upon occurrence of an over temperature or leakage condition so as to indicate that condition to other control components in the pump control panel. In the case of an over temperature, and in keeping with Flygt's warranty policy, the over temperature dry contracts shall be used to trip the pump offline. The MiniCAS shall be designed to be plugged into a standard 11 pin circular socket and shall be powered by a 24 VAC supply. Detailed technical data and wiring connections shall be found in the MiniCAS Manual.

#### H. Ground Wire Alarm Relay

1. The pump's ground conductor(s) and associated ground terminals shall be continuously monitored for open circuits, corrosion and loose connections. This monitoring shall take place in the pump control panel and shall not require the addition of any electrical/electronic circuitry within the pump. The standard pump cable shall be provided with a yellow ground check conductor in addition to the green ground conductor(s), to provide a continuous ground loop for monitoring.
2. A solid-state plug-in relay shall be provided to monitor the continuity of the ground loop and to measure the ground connections for a resistance of less than 500 ohms.
3. LED pilot lights shall provide an indication of a faulty ground condition and in the event of an alarm; the relay shall shut down the motor. A manual reset shall be provided to reset the alarm condition. A test push-button shall simulate an open ground wire and shall check the relay for proper operation.

#### I. SUBMEG and SUBMEG-D

1. Install one (1) completely enclosed solid state 12-pin plug-in electronic module to automatically monitor the motor winding insulation resistance. The modules for Simplex applications must have a Motor Reset button, an Emergency Bypass switch and a Low Meg indicator. The plug-in modules for Duplex applications

must have (2) Motor On/Off switches and indicators for 1 Meg and 5 Meg. Each automatic insulation resistance tester must have a Power indicator and a Meg Test button to test the internal circuitry of the module. (For a door-mounted module for Duplex applications refer to Page 19).

2. The power supply must be 110VAC, fused at 1.0 amp. The D.C. test voltage shall be 500 volts. The output current shall be limited to less than 3 micro amps. The module must also have one output circuit for external alarms.
3. When tested and the motor winding resistance drops to 1 Megohm or below, an alarm system must be activated by the internal circuit of the module. When using a SUBMEG-D, the motor continues to run. The SUBMEG for Simplex operation provides a choice of models where the motor either keeps running or will not start. The insulation testing device has to be either one of the SUBMEG/SUBMEG-D modules or an approved equal. Devices using D.C. test voltage less than 500 volts are not considered equal.

#### 5.4 ALARM SYSTEM

- A. The alarm light shall be a weatherproof-shatterproof red light fixture with a 40 watt bulb to indicate alarm conditions. The alarm light shall be turned on by the alarm level.
- B. The alarm horn shall be mounted on the exterior of the cabinet. The alarm horn shall provide a signal of not less than 90db at 10 feet. An alarm silence switch shall deactivate the alarm horn; however, the alarm light will flash until the alarm condition ceases to exist. At that time the alarm reset function will reset for normal operation.

(i) Logic Controls – The duplex logic control system shall consist of the logic chassis mounted on the sub-panel and the logic panel mounted on the inner door (deadfront), connected by a multi-conductor cable.

– Terminal Strip connection points for:

- Audible alarm
- External alarm light
- Flasher
- Power monitor
- Pump monitors (seal failure & over temperature)

- Pump lockout and alarm circuitry for power failure, phase loss, low voltage, seal failure, pump over temperature, loss of prime
- Dim glow jumper for external visual alarm
- Chassis permanently marked identifying components and function
- Terminal strips permanently identified with numbers and graphic symbols indicating the function of each point

#### LOGIC CONTROLS – ALARM AND MONITORS

Elapsed time meters (2), six-digit, non-resettable.

High Level Alarm Light – A NEMA 4X, red lexan, vandal resistant globe and 40-watt lamp shall be mounted on top of the enclosure. The globe shall be mounted with stainless steel screws and closed cell neoprene gasket to insure water-tight integrity.

Flasher – A flasher shall be installed and connected to the logic chassis to provide flashing alarm light.

Seal Failure – Moisture sensing relays shall be installed and connected to the logic chassis for each pump to lock out the appropriate pump motor starter and illuminate the red LED indicator on the logic chassis. (Moisture sensing probes supplied and installed in pumps by pump manufacturer.)

(ii)

Power Handling:

Main Lugs – Main lugs of the appropriate size shall be furnished for connecting the incoming supply power. The lugs shall be suitable for use with aluminum or copper conductors. Pump motor circuit breaker line side lugs do not qualify as main lugs.

Ground Lugs – Ground lugs of appropriate size shall be bolted to the sub-panel.

Motor Circuit Protection – Motor circuit protection shall be selected in accordance with the National Electric Code and be either thermal magnetic circuit breakers or magnetic motor circuit protectors. Either type shall contain a self-test "Trip Selector" permitting a mechanical simulation of the over-current tripping device.

Magnetic motor circuit protectors shall provide instantaneous clearing of faults to a minimum of 10,000 amperes, RMS, symmetrical. The magnetic motor circuit protector shall have an adjustable instantaneous trip setting.

Revised May 15, 2024

Circuit breaker toggles shall be operable through cutouts in the inner door (deadfront).

NEMA Rated Motor Starters – The motor starters shall be FVNR, with overload relays and reset buttons. Definite purpose conductors or horsepower rated motor starters are not acceptable.

Overload Reset – Motor starter overload reset operators shall be installed on the inner door.

Control Power Transformer – The transformer shall be 500VA capacity minimum when source voltage is 460Volt, 3-phase, 3-wire, or when 120VAC power supply is not available.

Lightning Arrestor – A secondary arrestor complying with ANS1C62.2-1981 shall be installed.

(iii) General Features:

All control wiring external to the logic chassis shall be numbered on each termination.

All components must be mounted with stainless steel hardware.

Space Heater – A heating system shall be supplied to maintain the interior temperature 2-3 degrees F above ambient temperature to prevent condensation within the enclosure.

MANUFACTURER'S WARRANTY – The manufacturer of the pump controller shall warrant it free from defects in materials and workmanship for:

1. Five (5) years on the liquid level indicator/controller
2. Two (2) years on all other components supplied and installed by the panel manufacturer

TESTING BEFORE SHIPMENT – Each panel shall be tested to assure proper operation of every function. Test records shall be retained by the manufacturer and be made available to the owner if requested.

Dry contacts shall be supplied for remote indication of high water alarm.

(d) Duplex Pump Control Panel:

Provide a Duplex Pump Control Panel including the following control functions and auxiliaries:

1. Manual-Off-Automatic selector switch, green running pilot light, red failure pilot light, and red seal failure pilot light for each pump.
2. A PUMP NO. 1 LEAD-ALTERNATIVE-PUMP NO. 2 LEAD sequence selector switch to select either pump as lead pump or to select that the pumps alternate as lead pump on each call for cycle.
3. Level inputs for: stop, lead pump start, lag pump start and high water alarm, low water alarm
4. Pilot light indicators for each level input.
5. A field adjustable failure time delay for each pump. Controls to start the lag pump at the lead pump start level if the lead pump fails or if the lead pump selector switch is placed in the off position. If a pump fails, the remaining functional pump shall remain the lead pump on future cycles. The failed pump shall only be called to operate at the lag pump operating level. Normal pump alternation shall resume when failure condition is corrected and pump has been reset.
6. Soft start feature to require the pumps to start three (3) seconds apart during conditions that the lead and lag pumps are called for simultaneously and must have a common off
7. Individual field adjustable time controls to delay starting each pump in the automatic mode after power failure or during initial start-up.
8. A red high water alarm pilot light and common exterior alarm light with red Lexan lens. The exterior alarm light shall burn dimly during normal conditions to indicate power on and the lamp good, and shall flash brightly during high water level, pump failure, or seal failure.
9. Pump failure, pump seal failure and high water alarm red pilot lights shall flash when activated.

All selector switches, pilot lights, and other panel mounted devices shall be mounted on an interior deadfront panel. The deadfront panel shall be constructed of anodized aluminum and shall have a continuous aluminum hinge.

Provide input indicator and test module with improper input sequence indicator and controls. The following controls and equipment shall be supplied:

1. If stop input fails, followed by lead input activation, lead pump shall operate and continue until lead pump input is removed
2. If stop input fails, followed by lead and lag input activation, both pumps shall operate and continue until their respective input is removed and an individual field adjustable time delay for each pump has expired.
3. If stop and lead input fails, followed by lag input activation, both pumps shall operate - until "off" is activated.

The controller shall be telemetry ready providing dry contact closures for the following signals:

1. Pump running (Qty. 2)
  2. Pump failure (Qty. 2)
  3. Pump seal failure (Qty. 2)
  4. Station high-level alarm
  5. Improper sequence (if Option No. 1W1 is selected)
- NEMA-4X construction
  - Hinged Interior Deadfront
  - Manual-Off-Automatic selector switches
  - Running pilot lights
  - Pump Failure pilot lights
  - Seal Failure pilot lights
  - High Water Alarm pilot lights
  - Automatic Pump Alternation
  - Level and Moisture Sensing Circuits with Intrinsic Safety
  - Pilot Light Indicators for each level input
  - Exterior Common Alarm Light
  - Pump No. 1 Lead-Alternate-Pump No. 2 lead selector switch
  - Lag Pump Start at Lead Pump Level if lead pump fails
  - Lead and Lag Pump Delayed Start
  - Field Adjustable Time Delay Start on each pump after power failure
  - Isolated Common Alarm Output
  - Main Circuit Breaker (operable through deadfront)
  - Lightning Arrestor
  - System Phase Monitor
  - Elapsed Time Meters (one for each pump)
  - Elapsed Time Meter (both pumps running)
  - Duplex Receptacle
  - Cabinet Heater and Thermostat

(e) Triplex Pump Controllers

Provide a triplex pump controller, including the following features for each pump:

1. Operations and Indicators
  - Manual-Off-Automatic selector switch
  - Green "Running" pilot light
  - Red "Failure" pilot light
  - Red "Seal Failure" pilot light
2. Level Inputs
  - Individual – "On" level input control points shall be provided for each pump
  - Provide a "High Liquid Level" alarm input sensing point.
  - Provide pilot light indicators for each level input sensing point.
3. Input Monitoring and Control
  - If the level continues to rise, and a third start input is activated, all pumps shall start.
  - Pumps shall operate until the - "off" is activated.
4. Intrinsic Safety devices
5. Pump Sequencing
  - Pump alternation shall be selectable to alternate as lead pump on each lead pumps call for cycle or to alternate on a first pump "On" first pump "Off" basis on falling liquid level and first pump "Off" on previous cycles, to be the first pump "On" on current cycle on rising liquid level.
  - The pumps shall also alternate as lead pump, when the lead pump reaches a field adjustable running time period. has cycled
  - Provide a field adjustable failure time delay for each pump. If a pump fails, or if that pump selector switch is placed in the off position, provide controls to start the next pump in the pumping sequence at the failed or disabled pumps operating level.
  - 
  - Provide individual field adjustable time controls to delay starting each pump in the automatic mode after power failure or during initial start-up.

- Pump failure, pump seal failure, high water alarm and improper sequence alarm red pilot lights shall flash when activated.

#### 6. Annunciating

- Provide a pump running discrete output contact for each pump.
- Provide an individual discrete output alarm contact for each pump failure condition.
- Provide an individual discrete "Seal Failure" output alarm contact for each pump.
- Provide an "Improper Level Input Sequence" discrete output contact.
- Provide a "High Level Alarm" condition discrete output contact.
- Provide a common alarm discrete output contact that will actuate when any alarm condition occurs.

#### 7. Power and Control Components

- Provide properly sized circuit breaker and starter with NEMA Class Ten (10) ambient compensated overload protection for each pump.
- Provide individual phase failure protection for entire control (1 phase monitor).
- Provide a common exterior alarm light with red Lexan lens. The exterior alarm light shall burn dimly during normal conditions to indicate power on and lamp good, and shall flash brightly during high liquid level, pump failure, pump seal failure or during improper input sequence alarm condition.

#### 8. Controller Enclosure (Standard)

- All selector switches, pilot lights, and other panel mounted devices shall be mounted on an interior deadfront panel.
- The deadfront panel shall be constructed of anodized aluminum and shall have a continuous aluminum hinge.

### Standard Features

- NEMA-4X construction
- Hinged anodized aluminum deadfront
- Manual-Off-Automatic selector switch each pump
- Running pilot light each pump
- Pump failure pilot light each pump
- Seal failure pilot light each pump
- High Liquid Level pilot light
- Individual - "On" level input control points for each pump
- Common "Off" controls
- Automatic pump alternation on each lead pump "Call" cycle
- Intrinsic Safety
- Exterior common alarm light
- During pump failure start next pump at lag setting
- Field adjustable time delay starting on each pump after power failure
- Annunciate pump running conditions, level input sequence, and all alarm conditions
- Class 10, ambient compensated overload, and single-phase protection
- Isolated "Pump Running", "Pump Failure", "Pump Seal Failure", "High Level Alarm", and "Common Alarm" discrete contact outputs
- Soft start - pump control (no pumps start or stop at same time to prevent excessive inrush current and water hammer)
- NEMA 4X stainless steel construction with anodized aluminum interior deadfront and three-point locking handle

### Component

- Main Circuit Breaker
- System Phase Monitor
- Elapsed Time Meters
- Duplex Receptacle
- Cabinet Heater and Thermostat

(f) Automatic Pump Sump Cleaning System

The Authority may direct the Applicant to provide a Flygt APF-Cleaner automatic pump sump cleaning system to override the primary level control system on a preselected basis to initiate periodic cleaning cycles. The APF-Cleaner system shall supplement the primary control system and enable presetting the controls

to pump down the liquid level in the wet well to the minimum allowable water level. The number of cleaning cycles per 24-hour period shall be preset and shall function on a periodic basis within the normal routine pumping cycle.

#### **12.12.5 Electrical Equipment**

- (a) Electric motors and electrical power equipment shall be explosive proof and damp-proof.
- (b) All electrical equipment and work shall comply with Fire Underwriter's regulations for the location involved and to the National Electric Code.
- (c) Provide 12-gauge, type 316, stainless steel, vandal-proof, and all weather electric control box cover on double supports.
- (d) Locate all control centers for easy access.
- (e) Provide approved receptacle, transfer switch and circuit breaker for auxiliary portable generator, depending on size of station, to compliment existing Monroe Municipal Utilities Authority equipment and be satisfactory to the Conectiv Electric Company.
- (f) Electric service shall be three phase unless otherwise approved by the Authority.
- (g) Provide schematic wiring diagrams to include Authority standard receptacle outlet for auxiliary power generator and Atlantic City Electric Company approved transfer switch.
- (h) Provide dial tone line for automatic remote monitoring system.

#### **12.12.6 Site Plan**

- (a) Provide legal description for property to be transferred to the Authority.
- (b) Landscaping shall be provided consistent with the site restoration/landscaping plan or to the satisfaction of the Authority.
- (c) Provide a six-foot (6') high, white, polyvinyl chloride (PVC) fence and a twelve-foot (12') wide (minimum), motorized, cantilevered gate, with remote operator
- (d) The access driveway to the site shall be paved twelve feet wide, either concrete or asphalt (2" FABC surface course, two-inch (2") stabilized base course on six-inch (6"), quarry processed stone base).

- (e) The site shall be positively graded to direct drainage runoff away from the pump station and appurtenances. Existing and proposed 1' contour lines shall be shown on the site plan.
- (f) Provide gneiss aggregate, 6" thick, at the site in all areas not paved to, and including, the area beneath the perimeter fence.
- (g) Provide minimum lot size of 55' x 90' (as shown on Detail# PS-3) for the site to allow for equipment removal and mobility.
- (h) Minimum easement width for sewers is twenty (20) feet for sanitary sewers that are not more than fifteen (15) feet deep. For sewers that are more than fifteen (15) feet deep, easements shall be a minimum of thirty (30) feet wide. The depth of the sewer shall be measured from the design invert of the pipe to the surface of the proposed final grade.
- (i) Concrete monuments shall be set at all pump station lot property corners.

A site plan shall be submitted detailing the above items.

#### **12.13 Easements**

- (a) No sanitary sewer or force main shall be installed on private property unless the owner of the land is to own and maintain the pipe or an easement is deeded to the Monroe Municipal Utilities Authority. All easements shall be a minimum of twenty (20) feet wide unless the depths of pipe, soil conditions, or additional utilities require greater width. For sewers that are more than fifteen (15) feet deep, easements shall be a minimum of thirty (30) feet wide.
- (b) A separate legal description and plan of easement shall be prepared for each lot affected by the sanitary sewer and/or force main to be installed on private property.

An access road at least twelve (12) feet in width shall be constructed along the route of any and all sanitary sewer mains constructed within easements outside of the public right-of-way unless said mains are located within a paved area. The access road shall be centered along the main unless directed otherwise by the Monroe MUA Superintendent. The access road shall be able to support and be accessible for all Monroe MUA maintenance vehicles. The Engineer's Report shall include design calculations verifying the adequacy of the proposed access road surface to support those vehicles.

#### **12.14 Electrical Service General**

The new main service shall be installed in hot dipped galvanized steel conduit from the weather head on the service to the control panel and on to the wet well. All wiring outside the pumping shall be in heavy galvanized rigid metal conduit and shall be type THWN

The electrical work shall be done in strict accordance with the National Electrical Code National Regulation of the Board of Fire Underwriters. Upon completion of the work the contractor shall obtain and present to the Authority and Authority Engineer certificates of approval relating to the complete installation, issued by the Inspection Bureau having jurisdiction in this territory.

All electrical materials shall be new and listed by the Fire Underwriters Laboratories, Inc., shall meet with their requirements and shall bear their label. Before any materials or equipment are purchased, the contractor shall submit copies of all technical data, wiring diagrams, manufacturer's name, catalog numbers to the Authority and Authority Engineer for approval.

The applicant shall notify the Authority that an application has been made to the electric company to extend power to the station. A copy of this application shall be forwarded to the Authority for review prior to submission.

The applicant shall install a new underground service and electrical in the immediate vicinity of the pump station. The exact location of the service will be determined by the electric company.

The applicant shall pay all cost charged by the electric company for extending of service, meter, etc.

End of Section

## SECTION 13 - MINIMUM TECHNICAL DESIGN STANDARDS - WATER

### 13.1 Preliminary Plans

In the case of extensive or involved projects, or those for which deviations from these Rates, Rules and Regulations are anticipated, the preparation of a preliminary report and plan is advisable before detailed design proceeds; and it is recommended that the preliminary data be discussed with the Authority Engineer before final decisions are made.

### 13.2 Applications for Approval

Applications for approval of plans and specifications shall be submitted by a qualified professional engineer licensed to practice in New Jersey. Plans submitted by such an engineer shall bear his seal (R.S. 45:8-45).

### 13.3 Engineering Data to be Submitted

The following materials shall accompany the application for approval:

- (a) An Engineer's Report, signed and sealed by the design engineer, to include the information described below.
- (b) Maps, plans and specifications, signed and sealed by the design engineer.
- (c) Total estimated cost of the proposed project.

### 13.4 Engineer's Report

The Engineer's Report shall, when pertinent, contain the following information:

- (a) Description of existing waterworks as related to the proposed project.
- (b) Data on present and future population served by the facility together with present and anticipated water requirements and the relationship of the proposed works to these factors. Estimates shall be for a period of twenty-five (25) years.
- (c) Information on the source of supply, to include the following data:
  - 1. If from a surface sources; the dependable yield, characteristics of the quality of the water in relation to its treatability; information obtained as a result of a sanitary survey on the sources of pollution; and the existing or proposed measures to insure protection of the supply.

2. If from an underground source, data on the geological strata expected to be penetrated and the effect that such strata may have on the quality of the water; available information on yield and water quality; test well findings (if any); sources of potential pollution within a minimum distance of five-hundred (500) feet or, in the case of adverse geological conditions such as creviced or fissured rock formations, from a larger area; and a general description of the construction features proposed to protect the source from pollution.
  - (d) A description of significant pumping equipment, giving capacity of units and general information on the arrangement of facilities, including the provisions of standby power (if provided), control of operation, and alarm systems.
  - (e) A summary of proposed treatment processes with data to establishment that the proposed will produce adequate protection of the water so treated, together with sufficient information on the nature and dosage of any chemicals applied to provide the reviewer with a clear understanding of their operation. Normal capacity of each unit shall be given to show that the requirements of these Rates, Rules, and Regulations are being met.
  - (f) The methods proposed for the treatment and disposal of sludge and filter backwash.
  - (g) Sanitary features of proposed storage, transmission, and distribution works.
  - (h) That portion of the system to be built at the present time.
  - (i) A description of an investigation of the existing water distribution system to determine system pressures and available flows to ensure the system can meet the domestic and fire flow demands of the proposed project. The results of that investigation shall also be incorporated in the Engineer's Report. To ensure the system would be adequate throughout the entire year, flow testing shall be conducted during the months of June through August, subject to the approval of the Authority. The applicant must obtain Authority approval prior to conducting any flow testing of the Authority water distribution system.
  - (j) The estimated overage and peak daily water demands of the proposed development.

### 13.5 Maps

A map or maps in sufficient detail to aid in the examination and comprehension and the specific project covered by the application shall be embodied with, or accompany, the plans and specifications. All maps shall be drawn to a suitable standard scale, shall be properly titled, and the north point and datum shall be indicated. Topography shall be

shown by elevations, contours or other suitable methods. Roads, streams, municipal boundaries and other features shall be shown, including applicable data such as watersheds, reservoir locations, wells and well fields, water treatment plants, existing transmission and distribution mains, storage tanks, fire hydrants, and potential sources of pollution such as sewers and sewage disposal units.

## **13.6 Plans**

### **13.6.1 Details**

Plans shall be drawn to standard scales on uniformly-sized sheets. Each sheet shall contain necessary titles, scales, dates, owner's name and the general description of the project. The name of the engineer and his seal shall be shown on each sheet.

The preferred size is a drawing having a height of twenty-four (24) inches and a length of about thirty-six (36) inches including suitable margins. Drawing size should not generally exceed 30" x 42". Lettering should be sufficiently large to permit reduction, and all plans should have graphic scales.

If there is more than one (1) sheet, all shall be bound together and, in the case of transmission and distribution mains, an index map shall be supplied showing by number the area and districts covered by the various sheets.

All water main proposed for construction shall be shown on the plans in both plan and profile views, showing its proximity to other existing and proposed utilities and storm drainage systems.

The plans shall include detail drawings of all water distribution system appurtenances, such as fire hydrants, water service details, etc. All such details shall be consistent with the MMUA Standard Details.

### **13.6.2 Symbols**

All topographical symbols and conventions used shall be clearly defined. Water transmission and distribution mains to be built at present or constructed later shall be shown by suitable conventions.

### **13.6.3 Elevations and Dimensions**

Surface elevations shall be shown on all important parts of the work, with sufficient dimensions to permit verification of the operation of the facility. The elevations shall be based upon the North American Vertical Datum of 1988 (NAVD88).

## **13.7 Specifications**

Complete specifications shall be submitted covering the potable water facilities of the project. To conserve file space and to facilitate review of the data, sections dealing with general conditions of Contract, Notice to Bidders, Detailed Specifications for such items as doors, windows, fittings and fixtures, steel work, concrete, and wood work, should be omitted.

## **13.8 Ground Water Supplies**

### **13.8.1 Design**

The following criteria shall be considered in designing a water supply system for a realty improvement:

- (a) Availability of water from a public potable water supply within an economic distance from the realty improvement
- (b) Advisability of establishing a public potable water supply
- (c) A dependable source of water supply
- (d) Geology
- (e) Potential and known sources of pollution
- (f) A balanced system of supply, pumping, treatment, distribution and storage facilities to meet the peak demand

### **13.8.2 Alternate Design or Construction Features**

Proposed design or construction features of a water supply differing from the provisions of these standards may be approved upon submission of evidence to the satisfaction of the Administrative Authority that public health or safety would not be affected adversely by such design or construction and such proposed design or construction features did not permit lower standards than those required herein.

### **13.8.3 Water Consumption**

Water supply systems shall be designated to provide a minimum quantity of potable water as determined pursuant to Section 7:10-12.6 of the New Jersey Safe Drinking Water Act or Section 5:21-5.2 of the New Jersey Residential Site Improvement Standards, as appropriate.

When more than one (1) use will occur, the multiple uses shall be considered in determining water quantity. Small industrial plants maintaining a cafeteria and/or

showers; clubhouses or hotels maintaining swimming pools and/or laundries, are typical examples of multiple uses.

At private campgrounds, not less than fifty (50) gallons, per campsite, per day, shall be provided if privies are used. Where water-flushed toilets are used, at least one hundred (100) gallons per campsite per day shall be provided.

#### **13.8.4 Sources of Water**

The source of water shall preferably be from wells. However, the Administrative Authority may permit the use of springs, rainfall cisterns, and surface water.

#### **13.8.5 Grading**

Final grading shall provide adequate drainage of surface water away from the well and be of sufficient height to protect the sources of water supply from flooding.

#### **13.8.6 Freezing**

All parts of the water supply system shall be designed, located and constructed to protect against freezing.

#### **13.8.7 Cross Connection**

No (physical) cross connection shall be established between a water supply system serving a realty improvement and an approved public potable water supply unless approved in accordance with the provisions of N.J.S.A. 58:11-9.1 et seq.

#### **13.8.8 Priming**

A pump that requires priming, other than the initial priming following installation shall not be employed for any water supply system serving a realty improvement.

#### **13.8.9 Disinfections**

Upon completion of the installation of a water supply system or following repairs to its pumping equipment, it shall be flushed, disinfected with a chlorine solution, and thoroughly re-flushed to remove all traces of chlorine in a manner acceptable to the Administrative Authority.

#### **13.8.10 Duplicate Installations Required**

In supplies derived entirely from ground water sources, duplicate wells and pumping equipment, or equivalent, shall be provided when average water demand exceeds twenty thousand (20,000) gallons per day or the number of services exceeds one-hundred (100).

#### **13.8.11 Protection of Ground Water Sources**

Sufficient land shall be acquired around wells, infiltration galleries, springs, and similar sources of ground water developed for public water supply, as to satisfy the Department of Environmental Protection.

All land within a minimum of fifty (50) feet from a well shall be acquired by the owners of a public water supply system.

Any sewer or line carrying sanitary or industrial wastes which is within one-hundred (100) feet of a well shall be of steel, reinforced concrete, cast-iron or other suitable material; shall be properly protected, of completely watertight construction, and shall be tested for watertightness after installation.

No manholes or connections on a sanitary sewer system shall be permitted within one hundred feet (100') of a well.

#### **13.8.12 General Information Required**

The Engineer's Report required in accordance with the provisions of Section 13.4, shall include the following information:

- (a) General description of the construction of the ground water source
- (b) Test pumping report including maximum tested yield and drawdown
- (c) Capacity of pumping equipment installed and the control of its operation

#### **13.8.13 Information to be Shown on Map**

The map or maps required in accordance with the provisions of Section 13.5 shall show the following information:

- (a) Topography and the locations of existing, presently planned, and future planned ground water sources in the area under consideration. Each source shall be given an identifying number in chronological order of construction.
- (b) Elevations of wellheads above a common datum plane and highest known flood elevations.

- (c) Pollution hazards (such as septic tank systems, sewers, barnyards, and watercourses) are required.

#### **13.8.14 Formation Log**

The detailed plans and specifications shall be accompanied by a formation log showing the types and thicknesses of formation penetrated by the well or, in the event this information is not available at the time of the application, it shall be submitted to the Department of Environmental Protection, when the well has been constructed and prior to the approval of the well as a source of water for public potable and domestic purposes.

#### **13.8.15 Detailed Drawings**

- (a) A schematic drawing or drawings of the construction shall be included with as much detail as is practicable with the information available, and shall include:
1. Length, size, and locations of casings and screens.
  2. Method of sealing off shallow ground water from entering the well, including the sealing of the annular space between the drill hole and the outer casing and surface strata.
  3. Pumping unit, including prime and stand-by power sources.
  4. Plan and section of pump house or similar structure
  5. Method of connecting the well or other ground water source with the distribution system
- (b) A detailed drawing or drawings shall be submitted for the following construction:
1. Details of wellhead, including elevations of protective curbing, top of casing, pump house floor and surrounding grade.
  2. Method of sealing well head against surface pollutants.
  3. Provisions and locations of well vents and the methods for their protection against the entry of contaminating matter.

4. Well-head piping details, showing provision and locations of check valves, surge or air-relief valves, gate valves, sampling tap, water level indicator, discharge pressure gauge, and blow-off connection to permit pumping to waste.

#### **13.8.16 Applicability of AWWA Standards for Wells**

Subject to the provisions of this Section, minimum well construction standards shall equal applicable portions of the American Water Works Association Standard for Deep Wells (AWWA A100-66) or superseding standard.

### **13.9 Distribution Systems**

#### **13.9.1 Materials to be Submitted**

- (a) For new water supply systems, a plan showing the distribution system shall be submitted with the other engineering data. This shall show locations, diameters, and materials of the pipes, and location of hydrants, blowoffs, and main valves.
- (b) All extensions, additions, and improvements of transmission and distribution lines shall be submitted for review and approval.

#### **13.9.2 Capacity of Size of Mains**

- (a) Design capacity of water mains shall be such as to provide a minimum pressure of twenty pounds per square inch (20 psi), at peak day demand plus fire flow.
- (b) Unless a smaller diameter can be justified by the engineer, the minimum diameter of all distribution mains shall be six (6) inches. In any case, any pipe intended to supply fire hydrants shall have a minimum diameter of six (6) inches. A six-inch (6") main may be used when it serves not more than twenty (20) dwelling units and not more than one fire hydrant.
- (c) The design of the water distribution system shall be adequate to provide fire protection in accordance with the American Water Works Association (AWWA) Manual M31, "Distribution System Requirements for Fire Protection." It shall be the applicant's responsibility to obtain approval from the Monroe Township Fire Marshal and/or Fire Subcode Official as appropriate.

### 13.9.3 General Design Requirements

- (a) So far, as is practicable, distribution mains shall be laid in the loop system to eliminate dead-ends. Dead-ends, if unavoidable, shall have a fire hydrant, flushing hydrant, or blow-off hydrant (Mainguard 2" post hydrant; See detail) for flushing purposes; the determination of which shall be made by the Authority. Dead-end lines shall be permitted within the design of a looped system provided that there are no more than 20 dwelling units permanently, or no more than 50 units temporarily, on a dead-end line.
- (b) All distribution mains shall be provided with sufficient earth (four feet minimum), or other suitable cover to prevent freezing.
- (c) Water services and plumbing shall conform to the relevant local and/or State plumbing codes.
- (d) The specifications shall include provisions for the adequate disinfection of all new distribution mains before being placed into service.
- (e) Water mains and sewers generally shall be separated by a horizontal distance of ten (10) feet. If such lateral separation is not possible, the water and sewer pipes shall be in separated trenches, with the sewer at least eighteen (18) inches below the bottom of the water main. At crossings of sewers and water mains, and in situations where the sanitary sewer and water mains are parallel, the sewer shall be at least eighteen (18) inches below the bottom of the water main. Where this is not possible, the sewer shall be constructed of ductile iron pipe (Class 52) with mechanical or slip-on joints, or hot-poured lead joints, for a distance of at least ten (10) feet on either side of the crossing.
- (f) Sewer and water mains shall be located within the cartway of the roadway a minimum of three feet (3') from the face of curb; or within easements specifically dedicated to the Utilities Authority. Any other locations will be subject to the discretion of the Utilities Authority.

### 13.9.4 Water Crossings

- (a) Surface water crossings, both over and under water, present special problems, which should be discussed before final plans are prepared.
- (b) Sampling taps and valves will be provided at each end of a water crossing to facilitate sanitary control. (See detail)

### **13.9.5 Maintenance of Adequate Protection**

- (a) Chambers or pits containing gate valves, air-relief valves, blow-offs, meter, or similar appurtenances to a distribution system shall be suitably drained and shall not be connected directly to any storm sewer or sanitary sewer.
- (b) No blow-off, air-relief valve, flushing device, or hydrant drain shall be directly connected to a storm sewer or sanitary sewer.
- (c) The open end of an air-relief pipe shall be extended from the manhole or enclosing chamber to a point at least one (1) foot above the ground, and shall be provided with a down facing elbow and insect screen.
- (d) Except as permitted under the provisions of Chapter 47, P.L. 1966 (N.J.S.A. 58:11-9.1 et seq.) there shall be no physical connection between the distribution system and any unapproved source of water. No steam condensate, or cooling water from engine jackets or other heat-exchange devices, shall be returned to the potable water supply.

### **13.9.6 Easements**

- (a) No water main shall be installed on private property unless the owner of the land is to own and maintain the pipe or an easement is deeded to the Monroe Municipal Utilities Authority. All easements shall be a minimum of twenty (20) feet wide unless the depths of pipe, soil conditions, or additional utilities require greater width. Where the easement is adjacent to a public right-of-way, the Authority may approve a narrower easement if conditions warrant.

All easements shall be provided with an access road that shall support an 80,000 pound vehicle. Calculations shall be submitted in support of the access road design verifying its compliance with the support capacity requirement.

- (b) A separate legal description and plan of easement shall be prepared for each lot affected by the water main to be installed on private property.

## **13.10 Distribution Storage**

### **13.10.1 General**

- (a) Storage for finished water shall be provided as an integral part of each water supply system.

- (b) The location, size, type, and elevation of the equalization reservoir, standpipe, or elevated tank shall be such as to meet the distribution system pressure requirement contained in Section 13.9.
- (c) Unless a similar capacity can be justified by the provision of stand-by power, alternate sources of supply, adequate booster pumps or inter-connections, storage facilities serving the system by gravity shall be equivalent to approximately one day's water requirements.
- (d) In any system serving more than fifty (50) customers, hydro-pneumatic tanks will not be considered as providing adequate storage.
- (e) Clear wells, whether designed as separate structures or as part of the filter structure, shall meet the requirements for below grade reservoirs, as issued by the New Jersey Department of Environmental Protection.
- (f) Finished water shall not be stored adjacent to an untreated water compartment when only a single wall separates the two.
- (g) Each reservoir and tank shall be equipped with overflow and low-level warnings or alarms.
- (h) There shall be means available to determine water level elevations in each distribution storage unit.
- (i) Facilities shall be so designed as to permit dewatering for cleaning and maintenance without interrupting service. Direct connection to a storm sewer or sanitary sewer will not be permitted.

#### **13.10.2 Protection and Safety**

- (a) All equalization reservoirs, standpipes and elevated tanks shall be protected against unauthorized access and vandalism. Fencing, locks, and other necessary safeguards shall be provided.
- (b) Due regard, in the design of an elevated facility, must be given to the personal safety of the employees.

End of Section

## SECTION 14 - RELATED TECHNICAL STANDARDS - SEWER

### 14.1 Materials

Materials used in the construction of sewers, force mains, and outfalls shall be as follows:

- a. Gravity sewers shall be constructed of PVC pipe, or ductile iron pipe.
- b. Force mains, and outfalls shall be constructed of DIP, unless otherwise permitted by the Authority.

### 14.2 Ductile Iron Pipe

Ductile iron pipe shall conform to the requirements of the American Standards Association Specifications A21.51-17 as amended and revised to date. Unless otherwise specified herein, ductile iron pipe shall be thickness Class 52.

"Tyton" joints shall conform to the American National Standards Specifications A21.11-23 as amended and revised to date.

### 14.3 Polyvinyl Chloride (PVC) Sewer Pipe

Polyvinyl Chloride (PVC) sewer pipe shall be made of PVC plastic having a cell classification of 12454-B or 12454-C or 13364-B (with minimum tensile modulus of 500,000 psi) as defined in ASTM Specifications D1784-20.

Fittings shall be made of PVC plastic having a cell classification of 12454-B or 12454-C, or 13343-C as defined in Specification D1784-20. Compounds that have different cell classifications because one or more properties are superior to those of the specified compounds are also acceptable.

All fittings shall utilize rubber gasketed joints, the rubber gaskets complying in all respects with the physical requirements specified in ASTM F477-14 (2021), D1869-15, C361-22, or C443-21.

The pipe and fittings shall be homogeneous throughout and free from visible cracks, holes, foreign inclusions, or other injurious defects. The pipe shall be as uniform as commercially practical in color, opacity, density, and other physical properties.

PVC pipe and fittings shall be Type PSM SDR 35 for depths less than eight feet (8') and Type PSm SDR 35/26 for depths greater than eight feet (8') - Gravity Sewer Pipe conforming to ASTM D3034-21 as manufactured by Johns-Manville, Certainteed or approved equal.

## 14.4 Manholes

### 14.4.1 Construction

All manholes shall be constructed of precast reinforced concrete riser sections, an eccentric conical or flat slab top section, and a base section constructed of precast concrete. Where required, eccentric reducing sections shall be used to join riser sections of different diameters.

Pre-cast manhole sections shall be manufactured in accordance with ASTM Designation C478-22 latest revision. Manholes shall be manufactured by the "wet" process and shall be cured in the forms for several hours. The minimum compressive strength of the concrete for all sections shall be 4000 lbs. per square inch. The maximum allowable absorption of the concrete shall not exceed 9% of the dry weight. Tests shall be similar to those described in ASTM C497-20e1 latest revision. The circumferential reinforcement in the walls of all sections shall be a minimum of 0.12 square inch per linear foot for inside diameters up to and including 48 inches, and .0025 times the inside diameter in inches per vertical foot for larger diameter manholes. Reinforcement in flat slab top sections shall be designed for the load to be supported. Additional reinforcement shall be provided at all openings larger than six (6) inches.

Joints of the sections shall be formed entirely of concrete in accordance with ASTM Designation C443-21. The section joints shall be sealed with a permanently flexible, non-shrinking, non-oxidizing, sealant. The sealant shall also be resistant to environmental extremes such as temperature, acid and alkaline conditions. The sealant shall be BUTYL-LOK as supplied by Atlantic Concrete Products and installed in accordance with manufacturer's recommendations.

All pre-cast manhole bases shall have pipe to manhole flexible seals as manufactured by A-LOK Products Corp, specifically the "A-LOK" full compression seal. Waterways shall be constructed by a journeyman mason in the field after the manhole has been installed or have shall be precast by the manufacturer. The shape and size of waterways shall conform to the shape and size of connecting pipes as shown or ordered. Special care shall be taken to form channels with curved shapes that will provide the best hydraulic conditions for smooth flow. Benches shall be sloped to drain to the waterways. Concrete used in forming waterways shall be a stiff, rich mix, and shall be given a steel trowel finish. The minimum of flow channel shall be equal to 1/2 the diameter of the pipe to which it connects. The channel shall be graded to give a smooth, uninterrupted flow through the manhole.

The top of base walls, the ends of reinforced concrete risers and the bottom ends of pre-cast tops shall be so formed that when risers and tops are assembled with the base, they will make a continuous manhole. Joints shall be of such design as will permit effective joining and placement without irregularities in the interior wall surface of the manhole. Riser sections, conical sections, and the outer sides of flat slab top sections, shall be given a protective lining consisting of two (2) shop coats of asphaltic paint. The total dry film thickness shall be not less than 4 mils. The lining shall be applied in accordance with the manufacturer's recommendations. Coating shall be Koppers 300 M Epoxy or Pennsbury 32-B-4 Epoxy.

Foundation material under manholes shall be crushed stone at a minimum depth of 12 inches or as required by the Authority Engineer. The crushed stone shall conform to the quality and grading requirements specified in Section 901 of the New Jersey Department of Transportation Standard Specifications for Road and Bridge Construction for broken stone Coarse Aggregate No. 67.

Manhole frames shall be adjusted to finish grade by building a circular brick-in-mortar collar above the precast manhole opening. No more than three (3) courses of brick will be used to adjust frame to finish grade or frames shall be set to grade with a maximum of three (3) wire reinforced concrete grade rings meeting the standards of A.S.T.M. C478-22.

Maximum height of the collar shall be 12" except where otherwise ordered. Brick shall be sound, hard, well-burned, sewer brick conforming to the requirements of ASTM Designation C-32, Grade MA and shall be laid radially. Mortar shall consist of two (2) parts sand to one(1) part cement, thoroughly mixed in the required proportions before adding water. After laying up the collar and setting the frame in a full bed of mortar, the exterior of the collar shall receive a minimum 3/4 inch thick mortar coat to provide watertightness.

#### **14.4.2 Manhole Appurtenances**

Appurtenances shall include manhole frames and covers, and manhole rungs. All manhole appurtenances shall be manufactured in the United States of America.

Manhole frames and covers shall be of the best quality, close grained grey iron castings conforming to the requirements of ASTM Designation A48-22, Class #30. Seating surfaces of manhole frame and covers shall be machined to insure a nonchattering fit. Manhole frames and covers shall be properly cleaned and coated with a waterproof asphaltum applied by immersion, while

the castings are hot.

Unless otherwise indicated, manhole frames and covers shall be of the circular flared type frame with round flange equal to Catalog No. 1012A as manufactured by Bridgestate Foundry Company. All covers shall lay perfectly flat and true. All lids which "rock" and do not lay solid after construction has been finished, will be condemned and must be replaced by perfect lids.

Locking devices, equal to Catalog No. 1460A, shall be provided on frames and covers on all manholes located in easements. Locking type covers shall also be provided with a two-drop lifting handle.

Watertight frames and covers shall be equal to Catalog No. 1012A with "Flow Seal" as manufactured by Bridgestate Foundry Company.

All manholes set in other than roadway centerline locations shall have watertight frames and lids.

All covers shall be cast with the identifying letters shown. Letter shall be two inches (2") high and embossed against a recessed background.

Manhole rungs shall be extruded aluminum alloy of the step drop front design. Rungs shall be cast in the vertical sides of the manhole sections on twelve (12) inch centers. Manhole step dimensions shall meet the requirements of OSHA Standard 1910.23 for fixed ladders. The maximum distance from the manhole rim set to finish grade to ladder rung is fifteen (15) inches.

Special details shall be provided for drop manholes with invert differences exceeding two (2) feet, and for shallow manholes where the grade-to-invert depth is less than 5'-6".

Between manholes, pipe shall be straight and at uniform grade. Spacing shall not exceed 400 feet.

The Contractor shall modify existing manholes by coring setting pipe in place and filling with non-shrink grout. Waterways shall be chipped and roughened, and then finished with cement mortar to provide the best hydraulic conditions for smooth flow.

End of Section

## SECTION 15 - RELATED TECHNICAL STANDARDS - WATER

### 15.1 Water Mains

Water mains shall be cement lined ductile iron pipe conforming in all particulars to ANSI Specifications Designation A-21.51-17 for Class 52 pipe. Mortar lining for ductile iron pipe and fittings shall conform to AWWA/ANSI C104/A21.4-22. All fittings shall be cast iron and conform to the above standards.

On a case-by-case basis, the Authority may consider the use of polyvinyl chloride (PVC) water main pipe in lieu of ductile iron pipe. When authorized, the use of PVC pipe shall be for non-public elements of the water distribution system that are to be privately owned and maintained. PVC pipe shall conform to the specification for Eagle Loc 900 PVC pipe with internal joint restraint system as manufactured by JM Eagle. Pipe shall be pressure class 235 psi (DR 18) as described in AWWA C900-22 and FM 1612.

Marking tape and tracer wire shall be provided whenever PVC pipe or other non-metallic pipe is installed. The tape shall be of plastic material without integral wires or foil backing. The tape shall be not less than two (2) inches wide and shall have an identifying phrase in black letters repeated at maximum intervals of three (3) feet. The tape shall be of a type specifically manufactured for marking underground utilities. The tape shall be installed during backfilling operations. Tape shall be located two (2) feet below finished grade. The tape shall be centered on the utility line with the identifying phrase on top. The tape shall be blue with the identifying phrase "CAUTION – BURIED WATER LINE BELOW" in black letters.

Tracer wire shall not be integral to the marking tape. The wire shall be twelve (12) gauge solid copper wire encased in a protective plastic jacket. The wire coating color shall be blue. The wire shall be placed above the pipe line and shall be taped to the pipe at twenty-five foot (25-foot) intervals. The wire shall be installed continuously along the full length of the water main. If splicing is necessary, a direct bury splice kit shall be required. All other installation details shall meet the requirements of the Authority.

All components and materials of water mains shall be manufactured in the United States of America.

### 15.2 Ductile Iron Pipe and Fittings

Ductile iron pipe shall conform to the requirements of the ANSI Specification A21.51-17 as amended and revised to date. Unless otherwise specified herein, ductile iron pipe shall be thickness Class 52.

"Tyton" joints shall conform to the ANSI Specifications A21.11-23 as amended and revised to date.

Cement mortar lining for ductile iron pipe and fittings shall conform to the requirements of the ANSI Specification A21.4-22 as amended and revised to date.

Fittings shall be cast iron.

### **15.3 Gate Valves**

Valves shall conform to the requirements of the American Water Works Association Specification, as amended and revised to date.

Valves shall be inside screw, resilient seat gate type. They shall be designed for 200 psi working water pressure and have mechanical joint ends.

Valves stems shall be the non-rising type unless otherwise specified. Valves shall be operated by a 2" square wrench nut and shall open in the counter-clockwise direction. The direction of opening shall be marked on the nut by an arrow and the word "OPEN".

All cast iron surfaces of the valves shall be painted with three coats of asphaltum paint.

Valves shall be as manufactured by Mueller or approved equal.

### **15.4 Valve Boxes**

Valve boxes shall be cast iron, two-piece, 5-1/4", screw type, as manufactured by the Mueller Company, or approved equal.

Valve boxes shall be complete with covers and both valve box and cover shall be of ample strength and dimension to fully sustain the shocks of heavy vehicular traffic and to maintain the upper section and cover at proper grade under heavy vehicular traffic.

Covers shall have the word "WATER", an arrow showing the opening direction, and the word "OPEN" clearly cast thereon.

### **15.5 House Connections**

Materials for house service connections from the main to the exit side of the meter pit or curb stop, in the event the meter is inside the building, shall be copper Type "K" or approved equal with a minimum size of 1". The curb stop and box shall be installed and be of a type approved by the Authority.

Where water mains are PVC as described in Subsection 15.1 above, each service connection shall be fabricated with a full circumference stainless steel service saddle secured with stainless steel bolts, washers, and nuts. The service saddle shall be Smith-Blair 370 line or approved equal.

A meter pit shall adjoin the curb stop as shown in the detail in Section 23.

## 15.6 Fire Hydrants

Fire hydrants shall conform to requirements and tests of "AWWA Standard for Dry Barrel Fire Hydrants" C502-18 or latest revision.

- (a) The operating nut shall be one piece Bronze casting, pentagon shape measuring 1-1/2" point to flat.
- (b) Hydrants shall be three-way, having 2 to 2-1/2" hose nozzles and 1 to 4-1/2" pumper nozzle with threads conforming to the Monroe M.U.A. standard.
- (c) Hydrants shall be traffic model having upper and lower barrels joined approximately 3" above the groundline by a separate and breakable swivel flange providing 360-degree rotation of the upper barrel. This flange shall include a minimum of eight (8) bolts.
- (d) Hydrants shall be both tie-rodged and a thrust block set behind the hydrant bowl as shown in the detail in Section 22.
- (e) Fire hydrants shall be marked as shown on MMUA Standard Detail W-4.
- (f) Main valves shall be compression type and shall be 4-1/2" in diameter. Hydrants shall be equipped with drain valves which drain the barrel when the hydrant is closed and seal shut when the hydrant is open. These drain valves shall be an integral part of the upper valve plate and shall operate without employing springs, tubes, levers, or other mechanism.  
  
The bronze seat ring must thread into a bronze drain ring thus providing a bronze connection. The seat ring seals shall be "O" ring.
- (g) The 6" shoe connection shall be specified M.J. type unless otherwise noted. The shoe shall have ample blocking pads for sturdy setting and two strapping lugs to secure hydrants to piping. The interior of the shoe including lower valve plate and cap nut shall have a protective epoxy coating with a minimum thickness of 4 mils.
- (h) Fire hydrant shall be Mueller Centurion, Kennedy Guardian and American Darling.

End of Section

## SECTION 16 - RELATED TECHNICAL STANDARDS - GENERAL

The work shall conform in all respects to the requirements of Standard Specifications of the New Jersey Department of Transportation as amended and revised to date.

### 16.1 Cement

Cement used shall conform to the following requirements of the ASTM as amended and revised to date:

- (a) Standard Portland Cement - ASTM Designation C150-22, Type 1.
- (b) High Early Strength Portland Cement - ASTM Designation C150-22, Type 3.
- (c) Air Entraining Portland Cement - ASTM Designation C150-22, Type 1-A.
- (d) Air Entraining Agent shall be Vinsol Resin or Darex A.E.A.

### 16.2 Aggregates

Aggregates, both fine and coarse, shall conform to the requirements therefor of the N.J. Department of Transportation Standard Specifications as amended and revised to date.

### 16.3 Water

Water shall be clean, fresh and free of oils, acids, salts, organic matter, or other injurious substances.

### 16.4 Concrete

Unless otherwise provided, all concrete shall be air entrained having 4% to 7% of entrained air and shall be produced by using Standard Portland Cement with additive or Air Entraining Portland Cement with or without additional additive as may be required.

Except where otherwise specifically provided, concrete shall be Class A, B, C, or D, as prescribed, proportioned as follows:

<u>Class</u>	<u>Cement</u>	<u>Sand</u>	<u>Coarse Aggregate</u>	<u>Void Content</u>
A	1	.50	3.0	1.350
B	1	.75	3.5	1.575
C	1	2.00	4.0	1.800
D	1	2.25	4.5	2.025

When the coarse aggregate has a percentage of voids above or below 45, the volume of

coarse aggregate or sand, respectively, shall be decreased so that the volume of said voids will equal 90 percent of the sand volume. The volume shall be measured when the materials are dry and loose, not when they are rodded or shaken.

Class "C" concrete shall be used for the construction of concrete cradles and Class "D" for the construction of thrust blocks. Batching and mixing equipment shall be of a size and type suitable for work to be done and shall be subject to the approval of the Engineer. The class of concrete required for the various items of work shall be as shown on the plans or in the specifications.

#### **16.5 Reinforcement Steel**

Reinforcement steel shall be Grade 40, conforming to the requirements of either ASTM Standard A615-22 or ASTM Standard A711-17 (2022).

All steel is to be manufactured in the United States of America.

#### **16.6 Wire Mesh or Fabric**

Wire mesh or fabric shall conform to ASTM Standard A1064-22 as amended and revised to date.

#### **16.7 Concrete Block**

Concrete block for the construction of manholes, inlets, and catch basins shall conform to the requirements of the American Society for Testing Materials Specifications therefore, as amended and revised to date. Concrete blocks for manholes shall have the required radius and batter.

#### **16.8 Brick**

Brick shall be Grade MA conforming to the American Society for Testing Materials Specifications therefore, as amended and revised to date.

#### **16.9 Mortar**

Mortar shall be 1 : 2 cement-sand mortar.

#### **16.10 Iron Castings**

Iron castings shall conform to the requirements of the American Society for Testing Materials Specifications for gray iron casting as amended and revised to date, supplemented as follows:

All iron castings are to be manufactured in the United States of America.

Castings shall be boldly filleted and risers shall be sharp and perfect. The castings shall be true to pattern in form and dimension, free of pouring faults, sponginess, cracks, blowholes and other defects which affect their strength and value for the service intended. The bearing surfaces of frames, covers, and grates shall be fitted together so as to prevent rocking and the pieces match marked.

#### **16.11 Ladder Rungs - Aluminum**

Ladder rungs shall be fabricated of extruded aluminum alloy conforming to the current American Society for Testing Materials Specifications therefore and shall be subject to the approval of the Engineer. All ladder rungs are to be manufactured in the United States of America.

#### **16.12 Excavation and Earthwork**

##### **16.12.1 Limits of Excavation**

Excavation shall be made to approved lines which shall be of sufficient width for forming the pipe joints. Trench widths shall be selected so that the backfill will not exceed the safe load on the pipe. In all cases, the trench sides shall be vertical from the bottom to 12" above the top outside diameter of the pipe. In general, the widths of pipe trenches shall not be wider than the outside diameter of the pipe barrel plus two (2) feet at the level of the top of the pipe, unless otherwise approved. Trench bottoms shall be trimmed by hand to provide firm bedding. The last 3" of depth for all pipe trenches shall be removed with pick and shovel to the proper lines and grades before placing foundation material and pipe.

Blasting for rock excavation will be permitted only on approval of methods, and in compliance with applicable State and local regulations.

##### **16.12.2 Sheeting and Bracing**

Where excavations are made with sides at greater than natural slope, sheeting and bracing shall be used of sufficient strength to sustain the sides of the excavations and to prevent movement which could in any way injure the work or diminish the working spaces sufficiently to delay the work.

Sheeting shall be of a material that will not split while being driven. Sheeting and bracing shall conform to the requirements of the OSHA "Construction Standard for Excavations," 29CFR Part 1926.650-653, Subpart P.

### **16.12.3 Dewatering**

The Contractor shall provide, operate, and maintain satisfactory facilities and equipment including well points, with which to collect and pump all water entering excavations or other parts of the work to suitable places for disposal. All excavations shall be kept free of water until the work or structure to be built therein is completed. Water shall be discharged through pipe or gutters, or any other suitable artificial means to catch basins, watercourses, or ditches in such a manner as to avoid interference with business, pedestrian and vehicular traffic and so as to prevent damage to property.

### **16.12.4 Backfill**

All backfill shall consist of a suitable selected and approved earth generally from storage of approved excavated soil, free from rejected organic matter, boggy, peaty, humus or other unsuitable material such as silt, rubbish, waste, ashes, or cinders. If sufficient suitable material for backfill is not available from the excavated material, as determined by the Engineer, the Contractor shall procure elsewhere a sufficient quantity of suitable material and shall furnish and place such material. No frozen earth shall be used for backfill, and all stones more than 6" in the largest dimensions shall be removed from acceptable earth or fill and backfill. Unsuitable or excess backfill material shall be promptly removed from the site.

### **16.12.5 Placing and Compacting Backfill**

Backfill shall be made to the slopes, grades, and elevations required. Backfill shall be compacted, in an approved manner to a density at least equal to that of the adjacent undisturbed soil, so as to avoid future unequal settlement.

No backfill shall be placed until the structure has been inspected in place and approved. Backfilling shall be carried out as soon as possible after such approval.

Trenches shall be backfilled from the top of the foundation material to a depth of not less than 12" over the pipes using only bank run sand and gravel. Such material shall be uniformly placed on each side of the pipe in 6" layers, wetted as required, and firmly compacted by approved tamping machines. Care shall be taken not to damage the pipe. After a compacted coverage of 12" has been made, the remainder of the trench shall be compactly filled in an approved manner.

The bank run sand or gravel must be compacted after sprinkling with water to obtain optimum moisture content. Final in-place density must be at least 90% of the maximum density obtainable with the material used, as determined by AASHTO Designation T-99 Compaction and Density Tests, using Method "C".

#### **16.12.6 Foundation Material**

Foundation material used for pipe bedding, from a distance below the pipe invert to the lower quarter point of the pipe, shall be compacted crushed stone, conforming to the requirements of ASTM D448-12 (2017).

Pipe embedment material from the lower quarter point to 12" above the top of the pipe shall be a suitable back fill material. Suitable back fill material shall be loose sand or fine granular soil free of large stones, refuse, broken concrete, broken asphalt stumps organic matter.

All foundation material shall be placed and compacted as directed and approved by the Engineer.

#### **16.13 Pipe Laying and Installation**

All pipe and fittings shall be installed to the lines and elevations shown or ordered, and in accordance with the manufacturer's recommendations.

Suitable tools and equipment shall be used for proper handling, storing, laying pipe and fittings. In order to avoid damage to the interior coatings of pipe, lifting hooks or bars shall not be inserted therein. Each pipe and fitting shall be checked for defects and injuries as laying proceeds. Imperfect pipe materials shall be rejected and removed from the work. Pipe found to be defective after laying shall be removed and replaced by undamaged material.

The interior of all pipe shall be cleaned of dirt, and other deleterious materials, and kept clean, as the next section of pipe is laid. During the progress of the work, the exposed ends of the pipe shall be provided with approved temporary covers fitted to the pipe, in order to prevent material from entering the pipe.

Where pipe must be cut to fit as closing pieces, such cuts shall be evenly and squarely made in a workman-like manner with approved equipment. Injury to linings or coatings shall be satisfactorily repaired.

Where cast iron mechanical joint, Tyton or Ring-Tite fittings are used, the Contractor shall furnish and install Megalug joint restraints concrete thrust blocks, tie rods, or other approved means for preventing movements at joints, bends, tees, and other fittings as shown or directed. Joints must be thoroughly brushed with a wire brush to remove all loose rust or foreign material. Soapy water must be brushed over the joint surfaces and over the gasket. Bolts shall be tightened uniformly, using only torque-limiting wrenches to avoid over stressing the bolts. Bolt heads, nuts, and other unpainted surfaces shall be coated with two (2) heavy applications of black asphaltum varnish.

All pipe shall be laid in accordance with approved details. All pipe shall be laid on top of a layer of foundation material, and the same material shall be carried up to a level 4" from the bottom of the pipe. Where concrete cradles are used to support the pipe, foundation material will not be required. No solid blocking will be permitted under pipe. Joints shall be made in accordance with the recommendations of the manufacturer.

End of Section

## SECTION 17 - INSPECTION AND TESTING OF INSTALLED FACILITIES

### 17.1 Inspection of Sewage and/or Water Distribution System During Course of Construction

**17.1.1** All construction of sewerage or water distribution systems shall be under the jurisdiction of the Authority Engineer, either directly or through inspectors under his supervision.

- (a) The Authority Engineer shall enforce compliance with the approved plans and specifications.
- (b) The Authority Engineer shall have the authority to have the work discontinued in the event of non-compliance.
- (c) The applicant shall also furnish the name of the occupant, the street address, and lot and block numbers two (2) weeks prior to request for certification or occupancy from the Building Inspector in order that the wiring, meter installations and lateral inspections can be accomplished.
- (d) No sewer or water connections shall be made to the appropriate street main whether tested or not unless under the supervision and inspection of the Authority Engineer.

**17.1.2** A temporary, lock-proof bulkhead type plug shall be installed in the upstream (inlet) side of the manhole furthest downstream in any sewer main or branch under construction and shall remain intact and unloosened until written permission is received from the Authority Engineer to remove same. Water mains shall be capped, plugged or valves closed and shall remain intact and unloosened until written permission is received from the Authority Engineer to remove same.

### 17.2 Testing of Completed System

**17.2.1** All sewers and water mains shall be subjected to one or more of the following type test: Infiltration, Exfiltration, Alignment, Pressure, Deflection and/or Television Inspection. Test procedures are described in Appendix A.

- (a) **Water Supply Systems** - After the pipe has been installed and prior to the complete backfilling of the trench, the system shall be subjected to a pressure and leakage test. Procedure and methods of testing water supply systems are stated in Section I.1. of the Inspection and Testing Procedures Manual of the Monroe Municipal Utilities Authority.
- (b) **Infiltration** - Examine the sanitary sewer system for infiltration at the downstream end of the system after construction has been completed

and prior to any sanitary building connections. In the event there is infiltration, the source and volume of flow must be determined. Procedure and methods for checking and testing for infiltration are stated in Section II.1. of the Inspection and Testing Procedures Manual of the Monroe Municipal Utilities Authority.

- (c) **Exfiltration** (Gravity Sewer) - Exfiltration test shall be conducted in lieu of infiltration tests when the pipe has been laid above the groundwater level. Procedures and methods for performing exfiltration tests are stated in Section II.2 of the Inspection and Testing Procedures Manual of the Monroe Municipal Utilities Authority.
- (d) **Alignment** - Alignment shall be done on all gravity sanitary sewer lines regardless of any other testing that may be required by the Authority Engineer. See Section II.3. of the Inspection and Testing Procedures Manual of the Monroe Municipal Utilities Authority. (Appendix A)
- (e) **Deflection** - This procedure establishes the method to be used when testing PVC sanitary sewer pipe for maximum allowable pipe deflection (reduction in vertical inside diameter). The maximum allowable pipe deflection (reduction in vertical inside diameter) shall be 7.5%. See Section II.4. of the Inspection and Testing Procedures Manual of the Monroe Municipal Utilities Authority.
- (f) **Television Inspection** - This method of inspection will be employed at the final inspection of the interior of the sewers. See Section II.5. of the Inspection and Test Procedures Manual of Monroe Municipal Utilities Authority.
- (g) **Exfiltration (Force Main & Pressure Lines)** - After the pipe has been installed and before the complete back filling of the trench, the system shall be subjected to a pressure and leakage test. Procedures and methods of testing the force main and pressure lines is described in Section II.6. of the Inspection and Test Procedures Manual of Monroe Municipal Utilities Authority.

**17.2.2** In order to ensure that there shall be no gushing or spurting streams entering the sewer system, the Contractor shall be held responsible for watertightness of the line, shall satisfactorily repair all joints and other parts not sufficiently watertight and then shall make additional tests for infiltration or exfiltration until the test results conform to the given requirements.

**Note:** The Contractor shall furnish all labor, material, and equipment necessary for testing.

When individual or house connections are connected to sewer mains already tested, the individual or house connections shall be pressure tested prior to connection to the sewer main. Individual or house connections shall be pressure tested under a ten (10) foot head of water and shall be made tight from the point of connection at the main to the lowest clean out in the Building (See Plumbing Code) National Plumbing Code Book, Chapter 15.

Water pressure test should be made with pressure in excess of the normal anticipated water pressure.

### **17.3 Bacteria Test**

After flushing has been completed and the chlorine residual is not greater than 0.2 ppm, a Bacteriological sample shall be taken in accordance with the New Jersey Department of Environmental Protection Agency, Potable Water Standards Bulletin PW-D, December 1970, or the latest revision.

End of Section

## SECTION 18 - BILLING, PAYMENTS, DELINQUENCIES, ETC.

### 18.1 Rendering of Bills for Water and Sewer Service

A single bill for water and sewer services will be rendered monthly to each customer. The bill will be printed the first of the month and rendered as soon as thereafter as practicable.

Water charges will be based on the monthly readings read prior to the printing of the bill. In the event a meter does not register a reading due to miscommunication, an estimated bill based upon the previous year and month will be charged.

Sewer charges are billed in advance for the month beginning with the billing date.

### 18.2 Payment Schedule

If a bill is not paid within thirty (30) days of the date of billing, an interest rate of 1-1/2% per month will be charged.

### 18.3 Delinquent Accounts

Any bill unpaid after thirty (30) days of presentation shall be classified as delinquent. Any bill unpaid after forty-four (44) days of presentation shall be subject to discontinuance of service after not less than five (5) days of written notice.

If a customer's account becomes delinquent, after forty-four (44) days service shall be terminated until the past due amount is remitted to the Authority. All services discontinued for non-payment of bills shall be subject to a reactivation fee. (See Section 21 – Schedule 4).

If the service is discontinued for nonpayment of the account, it will not be restored until the turn-on fee plus all unpaid charges are paid or satisfactory arrangements have been made for payment (See Schedule 2).

If a property is turned off and a request by a realtor is made to turn the water on for inspection the entire balance on the account must be paid in full.

Any unpaid balance of service charges and interest hereon shall be a lien against the property and action shall be initiated pursuant to the procedures specified under N.J.S.A. 40:14B-32.

Notice of delinquent charges shall be given annually to the Tax Collector of Monroe Township 30 days before the Township posting notice of publishing all delinquent taxes.

The charges will include \$75.00 for lawyer's or collection agency fees, said charges to be considered additional service fees.

#### **18.4 Discontinuance of Service**

Service may, at the sole discretion of the Authority, be discontinued for any of the following reasons:

- (a) Misrepresentation in application.
- (b) Willful waste of water through improper or imperfect pipes.
- (c) Failure to comply with restrictions imposed pursuant to Section 19 - Reserve Supply.
- (d) Use of water for any other property or purpose than that described in the application.
- (e) Tampering any service pipe, meter, curb stopcock or seals, or any other appliance of the Authority.
- (f) Vacancy in excess of thirty (30) days (water only).
- (g) Refusal of reasonable access to the property for purposes of inspecting, reading, repairing, or removing meters.
- (h) Making, or refusing to sever any cross connection between a pipe or fixture carrying water furnished by the Authority and a pipe or fixture carrying water from any other source.
- (i) Nonpayment of bills within time prescribed.
- (j) Violation of any rules of the Authority.
- (k) Illegal water source obtained from another location other than the approved connection

#### **18.5 Renewal Service**

Service will be renewed when the conditions under which such service was disconnected are corrected and upon payment of all accrued charges provided in the Schedule of Rates or rules of the Authority.

**18.6 Abatement**

No abatement will be offered.

**18.7 Continuing Obligation to Pay Service Charge**

Upon connection of an improved and usable property to a sewer and /or water the obligation to pay the minimal service charge continues despite the failure to occupy the property or to use the sewer or water facilities, so long as the building or structure on the property is still available for use and the sewer and water facilities remain available.

End of Section

## SECTION 19 - RESERVE SUPPLY

The Authority shall have the right to reserve a sufficient supply of water at all times in storage, to provide for fire and other emergencies, or may restrict or regulate the quantity of water used by the customer in case of scarcity, or whenever the public welfare may so require.

End of Section

## SECTION 20 - RESPONSIBILITY FOR SERVICE

It is agreed by the parties receiving public fire service, private fire service, or any other services, that the Authority does not assume any liability as insurer of property or person, and that the Authority does not guarantee any special service, pressure, capacity or facility, other than is permitted by the ordinary and changing operating conditions of the Authority, as the same exists from day to day. It is agreed, by the parties receiving service, that the Authority shall be free and exempt from any and all claims for injury to any person or property by reason of fire, water failure to supply water pressure or capacity.

When a prospective customer has made application for a new service or has applied for the reinstatement of an existing service, it shall be presumed that the piping and fixtures on the applicant's premises are in good condition. The Authority will not be liable in any event, for any accident, breaks, or leakage arising in any way in connection with the supply of water or failure to supply same, or the freezing of water pipes or fixtures of the customer, nor any damage to the property which may result from the usage of water supplied to the premises.

No water will be furnished to any premises where any possibility exists of the mingling of the water furnished by the Authority, with water from any other source. Nor will the Authority permit its mains or service pipes to be connected in any way to any piping, swimming pools, tank, vat or other apparatus containing liquids, chemical, or any other matter which may flow back into the Authority's service pipes or mains, and consequently endanger the water supply.

Whenever any person, persons, firm or firms, partnership or partnerships, corporation or corporations, or any combination thereof causes or has caused any damage to the water or sewer system or facilities of the said Authority, the party or parties causing such damage shall immediately notify the Authority of such damage. The said Authority shall have the right to repair such damage or have such damage repaired and shall have the further right to recover the full cost and expense of such repairs, including, but not limited to, the standard charges for work performed by Authority employees, for materials, supplies and equipment used for such repairs from the party or parties causing such damage.

### 20.1 Complaints

Complaints with respect to the character of the service furnished, or the reading of the meters, or of the bills rendered, must be made at the Authority's business office, either orally, or in writing, and a record of such complaint will be kept by the Authority, noting the name and address of the complainant, the date, the nature of the complaint and the remedy.

### 20.2 Reasonable Access

The properly identified authorized agents of the Authority shall have the right of access to the premises served, at all reasonable hours, for the purposes of reading meters,

examining fixtures and pipes, observing the manner of using water and/or sewers, and for any other purposes which are proper and necessary in the conduct of the Authority's business.

### **20.3 No Oral Agreements**

No agent or employee of the Authority has authorization to bind it by and any promise, agreement, or representation not provided for in these Rates, Rules and Regulations.

### **20.4 Single Service - Water Only**

In instances where owners of existing properties make application for and are furnished only water service, all rules pertaining to water service must be complied with, and the charge for such service shall be as described in the Schedule of Rates.

### **20.5 Single Service - Sewerage Only**

In instances where owners of existing properties make application for and are furnished only sewerage service, all rules applicable to furnishing sewerage service must be complied with, and the charge for such service shall be as described in the Schedule of Rates.

### **20.6 Emergency**

As necessity may arise in the event of breakdown, emergency, or for any other unavoidable cause, the Authority shall have the right to cut-off the water supply temporarily, in order to make necessary repairs, connections, etc. The Authority will use reasonable and practical measures to notify the customer of such discontinuances of service but the Authority shall not be liable for any damage or inconvenience experienced by the customer; or any claim against it at any time for interruption in service, lessening of the supply, inadequate pressure, poor quality of water, or for causes beyond its control. When the supply of water is to be temporarily interrupted, written notice will be given, when practicable, to all customers affected by the temporary interruption of service, stating the probable duration of the interruption, and also the purpose of the interruption.

### **20.7 Discharges**

The discharge of any surface or subsurface water directly or indirectly to the sanitary sewer system is prohibited. Under drain systems for foundation of buildings shall be connected to a storm drainage system approved by the Township Engineer. Further, under drain systems in municipal rights-of-way shall have separate clean outs which shall not be in any appurtenance of the sanitary sewer system.

## **20.8 Mandatory Sewer Connections**

When the Authority provides for sewer to pass within 200 feet adjacent to a property owner's boundary line and upon notice of the availability of sewer, said property owner shall make the necessary arrangements to tie into the system provided for within 90 days of delivery of the written notice. Such written notice should be served by certified mail, return receipt requested. Upon the 91st. day, since notification, sewer charges are assessed regardless of direct connection.

The MMUA Permit Payment Agreement will be made available to any homeowner who is required to tie into the sanitary sewer system due to a mandatory connection.

Mandatory Water Connections - Rescinded by Board 03/20/02

### **20.8.1. Failure to Tie In**

Should a property owner, after the 90 days referred to in 20.8, fail to tie into the sewage facility provided for along the property owner's property line, then and in that event the Authority may make the tie-in or contract with a duly licensed contractor to effect the tie-in and the proceed against the property owner for the cost of the tie-in as well as other expenses including attorney fees incidental to the collection of the cost for the tie-in. If the tie-in has been commenced but not completed within the 90 days referred to in Section 20.8, the Authority may grant a reasonable extension of time to complete the tie-in.

### **20.8.2. Cost of Tie-In**

The property owner shall be responsible for the cost of all tie-ins for sewer.

### **20.8.3. Required to Tie-In**

Only improved properties with structures for either habitation or commercial use such as retail stores, manufacturing or service centers, but not limited thereto, shall be subject to

Section 20.8 through 20.8.2.

### **20.8.4. Tie-In or Lateral**

The terms "tie-in" or "lateral" are intended to be used interchangeably and shall be the same as found in Section 1.16.

## **20.9 Emergency Water Use Restrictions**

The Township of Monroe - Ordinance No.0:32-2000 Amending the Code of the Township of

Revised May 15, 2024

Monroe Establishing Chapter 273 Entitled “Emergency Water Use Restrictions” (See attached)

End of Section

ORDINANCE: O:32-2000  
AN ORDINANCE AMENDING THE  
CODE OF THE TOWNSHIP OF MONROE  
ESTABLISHING CHAPTER 273  
ENTITLED “EMERGENCY WATER USE RESTRICTIONS”

WHEREAS, the Township Council of the Township of Monroe has conducted an extensive review of the issue of water conservation within the Township; and

WHEREAS, the Township Council of the Township of Monroe has determined the following:

- Protracted periods of high temperatures and limited rainfall may cause excessive demands upon the water system of the Monroe Municipal Utilities Authority.
- A temporary lack of sufficient water capacity may result in lowering of the normal water levels of the sources of water supply to such authority.
- The excessive use of water during the spring, summer and fall months caused by sprinkling of lawns, filling of swimming pools, car washing, and other sanitary purposes and fire protection may cause a serious reduction in adequate pressure in the water distribution systems serving the residents of the Township.

NOW, THEREFORE, BE IT ORDAINED by the Township Council of the Township of Monroe that Chapter 273 of the Code of the Township of Monroe is hereby created as follows:

Section 1. Add the following sections:

- (A) Purpose. In the interest of the health, safety and welfare of the inhabitants of the Township, it is necessary to take all reasonable precautions and measures promptly to conserve water and maintain such water pressure as is necessary for sanitary, domestic and fire fighting purposes.
- (B) Declaration of Emergency. In case of an emergency whereby it is determined that the available supply of water is projected to become dangerously low, the Monroe Municipal Utilities Authority is hereby

authorized to declare by resolution, the existence of a water emergency. The resolution, hereinafter referred to as the “declaration” adopted by the authority, shall state that an emergency exists requiring the implementation of such measures for the conservation of water for domestic and sanitary purposes and fire protection as are specified in Subsection 3.

**Water Use Restrictions.**

- a. **Extent of Restrictions.** The declaration of emergency shall specify whether the emergency is one requiring full curtailment or partial curtailment of non-essential water usage, defined as follows:
  1. **Full Curtailment of Nonessential Water Usage.** An absolute prohibition of the use of water from the authority system for the sprinkling of lawns filling of swimming pools, car washing, and other similar non-essential uses until the emergency shall be terminated by declaration.
  2. **Partial Curtailment of Nonessential Water Usage.** The prohibition of the use of water from the authority system for sprinkling of lawns, filling of swimming pools, car washing, and other related uses, or any of the foregoing, on certain days of the week and/or during certain hours of the day. The terms of the partial curtailment shall be set forth in the declaration.
    - A. **Modification of Restrictions.** In the case of any such emergency declaration as is described herein, the terms of the curtailment may be modified by amendment from time to time based on any change in emergent conditions.
4. **Notice of Declaration.** Immediately following the passage of any emergency declarations hereinbefore described, a copy of the declaration shall be published in the official Township newspapers circulated in the township, and posted throughout the Township in the Municipal Building, Policy Headquarters, the offices of the Monroe Municipal Utilities Authority, and the Monroe Municipal Utilities Authority shall immediately notify all rate payers by regular mail of said declaration.
5. **Effect of Declaration.** The declaration of an emergency shall be conclusive of the fact of the existence of such emergency and shall be binding upon all persons and users upon the filing of the same in the office of the Township Clerk and the publication thereof in the official township

newspaper.

6. **Termination of Emergency Restrictions.** The restriction imposed shall terminate 120 days from the effective date of the declaration of emergency, unless sooner terminated by terms of the declaration or by further resolution of the Monroe Municipal Utilities Authority.
7. **Inspections.** During the water emergency, all premises receiving water from the authority system shall be subject to inspection by the authority's employees or any other person duly authorized and appointed by the Township or authority, to perform inspections to oversee compliance during the water emergency. It shall be a violation of this section for any person to hinder, obstruct delay, resist, or prevent any such inspection as is described herein.
8. **Violation of Restrictions.** It shall be a violation of this section for any person to use water from the Monroe Municipal Utilities Authority water system at any time during the water emergency in a manner prohibited by any declaration issued pursuant to this section.
9. **Continued Usage Deemed Public Hazard.** In the event that there is on any premises a continuing usage of water from the authority water system by any person in a manner prohibited by any declaration issued pursuant to this section, such continuing usage is hereby declared to be a public hazard.
10. **Notice of Violation.** The owner, occupant, and/or operator of the premises whereon the violation is occurring, shall be served with written notice of the violation by the delivery of such to any such owner, occupant, and/or operator, or the agent or employee of any of same actually of the premises. If no such person is present, the notice shall be posted on the premises.
11. **Abatement of Violation by Township Costs.** If after the passage of one hour from the delivery or posting of such notice, the health hazard has not been abated, any employee of the Township or the authority is hereby authorized to enter upon the premises to abate the health hazard. Thereafter, the Township or authority, as the case may be, shall assess the costs of such abatement against the owner, operator, and or occupant of the premises.
12. **Violations and Penalties.**
  - A. Any person found guilty of violating Subsection 8 shall be subject to a fine according to the following schedule:

1. Warning to \$100.00 for the first offense.
  2. \$300.00 for the second offense.
  3. \$500.00 for the third offense.
- B Any person found guilty of violating Subsection 9 shall be subject to a fine of \$500.00 for each 24 hour period, or part thereof, for which it can be proven that the violation occurred.
- C. Any person found guilty of renewing a continuing violation after it has been abated, shall be subject to up to 90 days imprisonment.
- D. No person shall be fined for any violation of any declaration issued pursuant to this section if such violation occurs less than 72 hours after passage of the declaration.
- E. It shall be a complete defense to any charge of violating this section if it can be shown that the defendant could not reasonable have known the violation was occurring because it was due to a latent defect in plumbing or other water conduits.

**Section II.** All ordinances or parts of ordinances inconsistent with the provisions of this ordinance, are hereby repealed to the extent of such inconsistency.

**Section III.** This ordinance shall take effect immediately after passage and publication as required by law.

#### TOWNSHIP OF MONROE

#### Certification

The foregoing ordinance was introduced at a meeting of the Township Council of the Township of Monroe held on August 8, 2000 and will be considered for final passage and adoption at a meeting of the Township Council of the Township of Monroe to be held on September 12, 2000, at the Municipal Building, 125 Virginia Avenue, Williamstown, New Jersey, at which time any person interested therein will be given an opportunity to be heard.

The foregoing ordinance was hereby approved by the Mayor of the Township of Monroe on the 15<sup>th</sup>. Day of September, 2000.

End of Section

## SECTION 21 - SCHEDULE OF RATES

### Section 21.1 - SCHEDULE 1 – SEWER SERVICE CHARGES:

#### **Residential Sewer Users:**

Residential sewer connections shall be charged an annual rate of \$528.36 per Billing Service Unit at \$44.03 per month. Residential users shall be billed monthly and shall be billed in advance.

Whereas the minimum number of service units will be determined in accordance with Table 1.

#### DISCOUNT RATES RESIDENTIAL SEWER EFFECTIVE JULY 1, 2025

Discount base rates are offered to residents who qualify for the New Jersey PAAD program and Senior Gold program. Annual recertification will be required. Failure to comply may result in discontinuance of the PAAD/SENIOR GOLD discount.

PAAD/SENIOR GOLD                      \$39.48 billed monthly

A 10% discount for base rates is offered to Active-Duty Military Personnel and Veterans or Surviving Spouses who meet the criteria.

VETERANS                                      \$39.62 billed monthly

MULTI-VETERANS                      \$35.22 billed monthly

#### **Non-Residential/Industrial Sewer Users:**

Non-residential users shall be charged at an annual rate the greater of \$528.36 per Billing Service Unit, or \$ 5.92/1,000 gallons effective July 1, 2025 per water meter based on monthly water consumption. Non-residential users shall be billed monthly and shall be billed in advance; excess water shall be billed on a monthly basis.

Whereas the minimum number of service units will be determined in accordance with Table 1.

#### **Commercial and Industrial Sanitary Sewerage Service:**

(a) Each commercial or industrial user of the sewer system shall pay a monthly sewer rental according to Definition of Classes.

(b) In cases where dwellings and establishments using the sewer system have sources of water supply other than, or in combination with water supplied by the Authority, such dwellings and establishments shall provide a meter on the other sources of supply. The total amount of water consumed, as shown by the sum rent pursuant to Definition of Classes.

(c) In cases where industrial users using the sewer system use water supplied from any source, and the water so supplied is not entirely discharged into the sewer system, the amount of water consumed is to be used as a basis for the computation of the sewer rent pursuant to Definition of Classes shall be determined by any of the following methods:

1. The industrial user, at his own expense, shall install a meter or measuring device approved by the Authority on his sewer connection with the sewer system and the readings from this meter or measuring device shall be used in computing the Sewer rent.
2. The industrial user, at his own expense, will install a meter or measuring device approved by the MMUA on the effluent not discharging into the sewer system and the readings from this meter or measuring device shall be deducted from the readings of all water meters and the remainder shall be used in computing the sewer rent.
3. If in the opinion of the Authority Engineer, it is not practical to install a meter or measuring device to determine the quantity of water not discharged into the sewer system, the Authority Engineer will determine in such manner and by such method as he may prescribe the percentage of metered water discharged into the sewer system, and the quantity of water used to compute the sewer rent shall be that percentage so determined of the total quantity measured by the water meter or meters. Any dispute as to the estimate percentage or amount shall be promptly submitted for determination to the Authority after notice of the estimate to the industrial user and the decision of the Authority shall be final for the current year.

Additional Surcharge for Treatment of Industrial Wastes:

Industrial wastes, highly concentrated wastes and pre-treated wastes, will be subject to a rate surcharge if they unduly add to the burden of the sewerage treatment plant as per GCUA regulations. The surcharge for industrial waste shall be based on an analysis of the industrial waste. The Authority will prepare an agreement outlining the methodology of the surcharge calculation and payment requirements by the applicant.

SCHEDULE OF WATER RATES EFFECTIVE JULY 1, 2025

Section 21.2 - SCHEDULE 2 – WATER SERVICE CHARGES:

**Residential Water Users:**

Minimum Rate:           \$23.70 per month - 3,500 gallons allowance monthly (per Service Unit)

Excess Rate: \$6.20 – 3,500 – 10,000 gallons  
 \$7.20 – 11,000 – 20,000 gallons  
 \$8.20 – 21,000 – 30,000 gallons  
 \$9.20 – 31,000 and over

Whereas the minimum number of service units will be determined in accordance with the Definition of Classes.

Each additional service unit served through the same meter shall be charged per month above the minimum charge. The minimum water charge shall be billed in advance and the excess shall be billed in arrears.

**DISCOUNT RATES RESIDENTIAL WATER EFFECTIVE JULY 1, 2025**

Discount base rates are offered to residents who qualify for the New Jersey PAAD program and Senior Gold program.

Annual recertification will be required. Failure to comply may result in discontinuance of the PAAD/SENIOR GOLD discount.

PAAD/SENIOR GOLD \$15.05 billed monthly

A 10% discount for base rates is offered to Active Duty Military Personnel and Veterans or Surviving Spouses who meet the criteria.

VETERANS \$21.33 billed monthly

MULTI-VETERANS \$18.96 billed monthly

**Temporary Construction Site Water Usage:**

Non-Authority Premises:

Water for building purposes shall be metered and charged \$6.20 per 1,000 gallons effective July 1, 2015 (see above excess charges)

Temporary metered service shall be provided for building purposes and other construction directly in connection therewith. The following rates will apply:

Application Fee ..... \$ 25.00

Deposit on service line adaptor  
 with meter (to be returned to user  
 when temporary service is terminated.) ..... \$ 750.00

All other items and provisions of the existing rates, rules and regulations adopted by said Authority previously are hereby declared in full force and effect, except only as herein specifically amended, revised or modified.

On Authority Premises and Assisted by Authority Personnel:

Water for building purposes shall be metered and charged \$50.00 for the first 1,000 gallons and \$6.20 per each additional 1,000 gallons

**Section 21.3 - TABLE 1 – DEFINITION OF CLASSES OF USE FOR DETERMINING SERVICE CHARGE MINIMUMS FOR SEWER AND WATER SERVICE UNITS**

Classes of Use	Service Units
Single Family Dwelling .....	1 Unit
Multiple Family Dwelling	
Townhouse .....	1 Unit
1 Bedroom Apartment .....	1 Unit
2 Bedroom Apartment .....	1 Unit
3 Bedroom Apartment .....	1 Unit
Hotel or Motel (per living unit) .....	1 Unit plus ½ Unit for each individual rental unit – Such establishments shall be charged one sewer and one water service unit fee as an entity, plus one-half sewer and one-half water service unit fee for each individual motel/hotel unit or room within said establishment.
	In the event said establishment has other uses, such as restaurants, banquet facilities, offices, etc., they shall be charged for such other uses in accordance with the applicable Section of Rate Schedule presently in effect.
Schools.....	The number of Pupils multiplied by gallons per person per day (SEE BELOW EXPLANATION) and divided by the current gallons per day (recomputed annually) determines the number of Domestic Consumer Units. Teachers and employees are classified as pupils for the purpose of this category.
School Facility with no cafeteria or showers.....	10 Gallons per person
School with cafeteria and no showers.....	15 Gallons per person
School with cafeteria and showers.....	20 Gallons per person
School with cafeteria, showers and laboratories...	25 Gallons per person

Bakery (with baking facilities – whether part of dwelling or not) .....	2 Units
Car Wash.....	1 Unit
Each additional bay.....	2 Unit
Clubs, Societies, Service Organizations (Non-Profit).....	1 Unit
with bar and/or restaurant facilities.....	3 Units
(For-Profit) per first 2,500 sq.ft. gross area..	1 unit
each additional 2500 sq.ft.....	1 Unit
Churches.....	1 Unit
Convenience Store: Example: Wawa, 7-11.....	2 Units
Diner, Tavern, Restaurant, Soda Fountain and/or Luncheonette (1-50 seating capacity).....	3 Units
Per each additional 15 seats.....	1 Unit
Drive-In Restaurants.....	3 Units
Dry Cleaning Establishment.....	2 Units
Industrial or Manufacturing Plant (without industrial waste), Per first 2,500 sq. ft. of gross area.....	1 Unit
Each additional 2,500 segment.....	1 Unit
Laundromat or Self-Service Laundry Each washer of not more than 12 lb. capacity.....	1/4 Unit
Each washer over 12 lb. capacity.....	1/2 Unit
Nursing Home Per first 10 inhabitants and staff.....	1 Unit
Each additional 10 inhabitants and staff.....	1 Unit
Office Building Per first 2,500 sq. ft. of gross floor area.....	1 Unit
Each 2,500 sq. ft. segment thereafter.....	1 Unit

Public Buildings .....	2 units
Retail and General Commercial Business	
Per first 2,500 sq. ft. of gross floor area.....	1 Unit
Each additional 2,500 sq. ft. segment thereafter.....	1 Unit
Retail and General Commercial Business with Restaurant Facilities	
Per first 2,500 square feet of gross floor area.....	1 Unit
Service Stations:	
a) Sale of Gasoline Only.....	2 Units
b) Sale of Gasoline and Retail.....	4 Units
c) Sale of Gasoline, Retail and Car Wash.....	6 Units
Supermarket (with retail)	
Per first 10 employees.....	5 Units
Per each additional 10 employees.....	1 Unit
Plus additional units for each section contained in market for pharmacy, deli, restaurant, video store and any other general business not in the grocery store business	
Take-Out Restaurant (without seating facilities).....	2 Units
Warehouse	
Per first 2,500 sq. ft. of gross floor area.....	1 Unit
and each additional 2500 segment thereafter.....	1 Unit

**Section 21.4 - SCHEDULE 3 – CONNECTION FEES/WATER & SEWER PERMITS:**

**Definition of Equivalent Dwelling Unit (EDU):**

Shall mean equivalent service unit and shall be equal to a dwelling unit using 179 gallons of service per day as of December 17, 2025, recomputed annually according to N.J.S.A. 40:NB.21.

**Attributing Service Units:**

In attributing service units to the issuance of water & sewer permits for residential and commercial accounts, the estimated daily flow of water for the connection shall be divided by the average daily flow of water to the average single-family residence in the Authority's district, to provide the number of service units to be attributed. (N.J. Statutes Annotated, Title 40, Section 40:14B-21.)

If, after one year, the applicant-owner has not shown proof of connection, the connection permit will be deemed invalid and the fees will be returned by the Authority. The applicant may, however,

renew his application for a period of one year evidenced by submittal of a new application. If, however, a new application is submitted at any time, the new application shall be at the prevailing fees at the time of submitting the new application. This section shall be strictly adhered to:

**Connection Fee Per EDU:**

Water Permit-Residential, Commercial & Industrial Users:

The connection fee for new water connections per EDU is \$4,016.00 for all size services. (Eff. 12/1/24)

The connection fee for a fire service connection is \$4,016.00 for all size services. (Eff. 12/1/24)

Meter and Meter Pit, Yolk/Flange, Tap Fee, Corp/Curb Stop, Curb Box and plumbing fittings will be assessed and is due at the time permit is issued.

Sewer Permit - Residential Users:

The connection fee for new sewer connections per EDU is \$2,763.00 (Eff. 12/1/24) for all size services.

\*A Gloucester Co Utilities Authority permit must be purchased before the Monroe MUA will issue an Authority sewer permit.

The Service Unit(s) assigned to the various class of users if listed under Classes of Use.

Additional Fees:

After the above applications have been reviewed one of the following permits may be required:

Township Street Opening Permit..... The applicant must apply for this permit from the Township Clerk prior to obtaining any Water/Sewer Permits.

County Road Opening Permit..... The applicant must apply for this permit prior to obtaining any Water/Sewer Permits.

State Highway Road Opening Permit..... The Authority will obtain this permit from the State for the applicant at the time they are applying for Water/Sewer Permits.

NOTE: The cost of the above permits are payable by the applicant and depends upon the location and size of the opening.

**Section 21.5 - SCHEDULE 4 – MISCELLANEOUS CHARGES**

Search Fee: ..... \$.05 per page

Returned Check Assessment..... \$ 25.00

Meter Service:

Service Charge for repair to  
tampered meter and parts..... \$ 50.00  
Damaged radio received on meter..... \$ 90.00  
Damaged Universal Cellular Endpoint  
with wire splice kit..... \$ 198.53

Service Restoration Fee:

Following shut-off for water delinquency during normal business hours..... \$ 50.00  
Following shut-off for water delinquency after normal business hours.....\$ 75.00  
Following shut-off for water delinquency if water is restored on a holiday ..... \$ 90.00  
Following shut-off for sewer delinquency..... \$ 150.00

Customer request for termination of water service ..... \$ 50.00

\*A request for termination of water service  
does not entitle that customer to an  
abatement for water charges. Minimum  
monthly water charges continue to be billed.

Restoration fee following water shut-off at customer's  
request ..... \$ 50.00

Test of meter at customer's request  
(for each water service meter having an outlet  
not exceeding 1 inch) ..... \$ 25.00

(per inch for other water service meters larger  
than 1 inch in diameter) ..... \$ 50.00

Final water readings..... \$ 25.00

Illegal water source obtained from another location other than the approved connection

First violation..... \$ 100.00  
Second violation..... \$ 250.00  
Third and each subsequent violation..... \$ 500.00

Sump pump illegally tied into the sanitary sewer system.. \$ 300.00

\*The \$300.00 fine will be assessed each month  
and applied to the customer’s account until the

connection has been corrected. (i.e. must be piped outside not just disconnected.)

All residential meters shall be maintained by the MMUA so far as ordinary wear and tear are concerned, but damage due to freezing, hot water or external causes shall be paid for by the customer:

Service charge to restore service where customer has turned water back on at curb after MMUA shut-off for delinquency and MMUA preventative action was required..... \$ 150.00.

Service charge to restore service where customer has unplugged sewer after MMUA shut off for delinquency and MMUA preventative action was required..... \$ 300.00.

Authority installation of separate lines for a single service unit with two or more customers:

Meter Pit.....	\$ 1014.66
Copper.....	\$ 451.20 (\$7.52/foot)
Backhoe.....	\$ 600.00
Topsoil.....	\$ 100.00
Concrete.....	\$ 300.00
Employees.....	\$ 1,200.00 (\$50.00/hr. @ 3 employees @ 8 hours)
Plumber.....	\$ 700.00 (Permit and install bladder tank)
Total Cost.....	<u>\$ 4,365.86</u>

Shuster Vent and/or Water Cap:

In the event a shuster vent and/or water cap is damaged and must be replaced this device can be purchased and installed by the homeowner.

If the homeowner request that the Authority purchase and install the device the homeowner must reimburse the Authority the cost of the product plus a labor fee of \$35.25.

**Section 21.6 - SCHEDULE 5 – FIRE SERVICE**

Public Fire Service..... There shall be no charge for water used for fire fighting purposes from a public fire hydrant.

Public Fire Hydrants will not be assessed any charges per P.L.2025, c.267 (effective Jan. 12, 2026)

Private Fire Service/Sprinkler Systems:

For each private fire hydrant, not connected to a metered service line ..... \$ 200.00 per annum (\$ 50.00/Qtr.)

For 2-inch metered or unmetered connection .....	\$ 200.00 per annum (\$ 50.00/Qtr.)
For 3-inch metered or unmetered connection .....	\$ 300.00 per annum (\$ 75.00/Qtr.)
For 4-inch metered or unmetered connection .....	\$ 320.00 per annum (\$ 80.00/Qtr.)
For 6-inch metered or unmetered connection .....	\$ 560.00 per annum (\$ 140.00/Qtr.)
For 8-inch metered or unmetered connection .....	\$ 1,000.00 per annum (\$ 250.00/Qtr.)
For 10-inch metered or unmetered connection .....	\$ 1,400.00 per annum (\$ 350.00/Qtr.)
For 12-inch metered or unmetered connection .....	\$ 1,680.00 per annum (\$ 420.00/Qtr.)

In addition to the above, an annual charge of \$ 0.35 per sprinkler head will be applied.

**Section 21.7 - SCHEDULE 6 - MONROE MUA WET TAP PRICE LIST**

The Monroe Municipal Utilities Authority shall perform all wet taps in accordance with this schedule unless otherwise specified.

**Resolution NO. 103-23**  
**Monroe MUA Wet-Tap Price Sheet** Approved 8/16/23

Tap Sleeve	Price
4x4	2600.00
6x4	2650.00
6x6	2700.00
8x4	2700.00
8x6	2900.00
8x8	3500.00
10x4	3100.00
10x6	3100.00
10x8	4100.00
10x10	6000.00
12x4	3500.00
12x6	3800.00
12x8	4700.00
12x10	6100.00
12x12	6800.00
16x4	4900.00
16x6	5600.00
16x8	6100.00
16x10	7200.00
16x12	8300.00

Tap Valve	Price
4"	900.00
6"	1200.00
8"	1900.00
10"	3000.00
12"	3600.00

Valve Box Complete = \$300.00

**Installation/Excavation:** \$6,500.00

Includes: excavation, crew, gas, fuel, machines, backfilling, temp restoration

\*Additional costs (if applicable) include:

- Local, County & State Permit Fees
- Traffic Plans
- Offsets and/or additional pipe work

**Restoration:** \$2,500.00

Includes: crew, labor, machines

\*All restoration materials additional cost (concrete, asphalt, etc.)

\*Final restoration is the responsibility of the developer/contractor

## Section 21.8 Violations/Fines/Penalties

Any violation to the Monroe MUA Rules and Regulations shall be subject to the following fines/penalties as deemed appropriate by the Monroe MUA. If the violation is not a “single offense” violation, each day the violation continues shall be considered a separate and distinct offense with cumulating fines and penalties until the violation is in compliance with the Monroe MUA Rules and Regulations. The fines and penalties for violations include but are not limited to:

- Illegal use of hydrants
  - All public fire hydrants are owned by the Monroe MUA
  - Privately owned water systems that do not have master meters may NOT use the fire hydrants
  - Only Monroe MUA employees and Monroe Township Fire Department are permitted to use the fire hydrants
  - The opening of fire hydrants for any reason without the Monroe MUA’s written approval **AND** supervision is prohibited
- Unauthorized connection to the Monroe MUA water or sewer system
- Tampering or damaging the water meter, meter pit or cellular signal
- Operating or tampering any part of the Monroe MUA water system which includes:
  - Curb stops, curb boxes, corporations, valves, sampling stations, fire hydrants
- Illegal dumping into Monroe MUA sewer system
- Illegal dumping of sewage into roadway/sidewalk

The fines for each violation shall be determined by the Monroe MUA.

Each violation is punishable by a fine not to exceed \$1,500.00 and/or imprisonment for a term not to exceed 90 days.

All fines shall be paid within 15 days of receipt of the written notice issued by the Monroe MUA.

All fines to be contested must be filed in writing to the Monroe MUA within 15 days of the notice of violation.

If the fine imposed is not paid, the Monroe MUA shall terminate the water and/or sewer service to the property in violation.

In the event water and/or sewer service cannot be terminated, the Monroe MUA will exhaust all other legal and equitable remedies authorized by law.

The fines and penalties imposed in this section shall be cumulative to the other fines and penalties described in other sections of the Monroe MUA Rules and Regulations.

## M.M.U.A. STANDARD DETAILS – 2024

### Sanitary Sewer

SS-1	Service Lateral with Concrete Curb Detail
SS-2	Deep Cut service Lateral Detail
SS-3	Deep cut Service lateral with Vertical Riser Detail
SS-4	Traffic Protector Clean-out Detail
SS-5	Service Lateral Trench Detail
SS-6	Manhole Cover Detail
SS-7	Watertight Manhole Cover Detail
SS-8	Manhole Grade Ring Detail
SS-9	Precast Manhole Detail
SS-10	D-Lok Joint Gasket Detail
SS-11	Drop Front Aluminum Rung Detail
SS-12	Typical Channeling of Manhole Bottom Detail
SS-13	Manhole Coring Detail
SS-14	Drop Manhole Detail
SS-15	Lifting Davit Detail
SS-16	Force Main Inside Drop Connection Detail
SS-17	Force Main Outside Drop Connection Detail
SS-18	Force Main Air Release & Vacuum Chamber
SS-19	Grease Trap Detail
SS-20	Sanitary Sewer Saddle Connection Detail
SS-21	Shallow manhole Detail

### Water

W-1	Water Service with Curb Detail
W-2	Water Service without Curb Detail
W-3	Thermal Coil Meter Pit Detail
W-4	Fire Hydrant with Curb Detail
W-5	Fire Hydrant without Curb Detail
W-6	Typical Joint Restraints Detail
W-7	Pressure Gauge Assembly Detail
W-8	Mainguard Blow-Off Hydrant Detail
W-9	Sampling Station Detail
W-10	Water Main Offset Detail
W-11	Tracer Wire Installation Detail

### Pump Station

PS-1	Pump Station By-Pass Vault
PS-2	Yard Hydrant Detail
PS-3	Pump Station Site Plan
PS-4	Standard Wet Well Detail
PS-5	Sign Detail
PS-6	Sign Plan

### Trenches & Pipe Installations

MT-1	Water & Sewer Main Installation with Curb
MT-2	Concrete Encasement & Saddle Detail
MT-3	Trench Compaction Detail
MT-4	Crushed Stone Class 'B' Modified Detail
MT-5	Class 'C' Shaped Bedding Detail
MT-6	Flowable Fill Trench Detail

### Miscellaneous - Other

MO-1	Townhouse Utility Plan
MO-2	Grass Paver Block Detail
MO-3	Typical Condominium Utility Plan
MO-4	General Sanitary & Water Notes

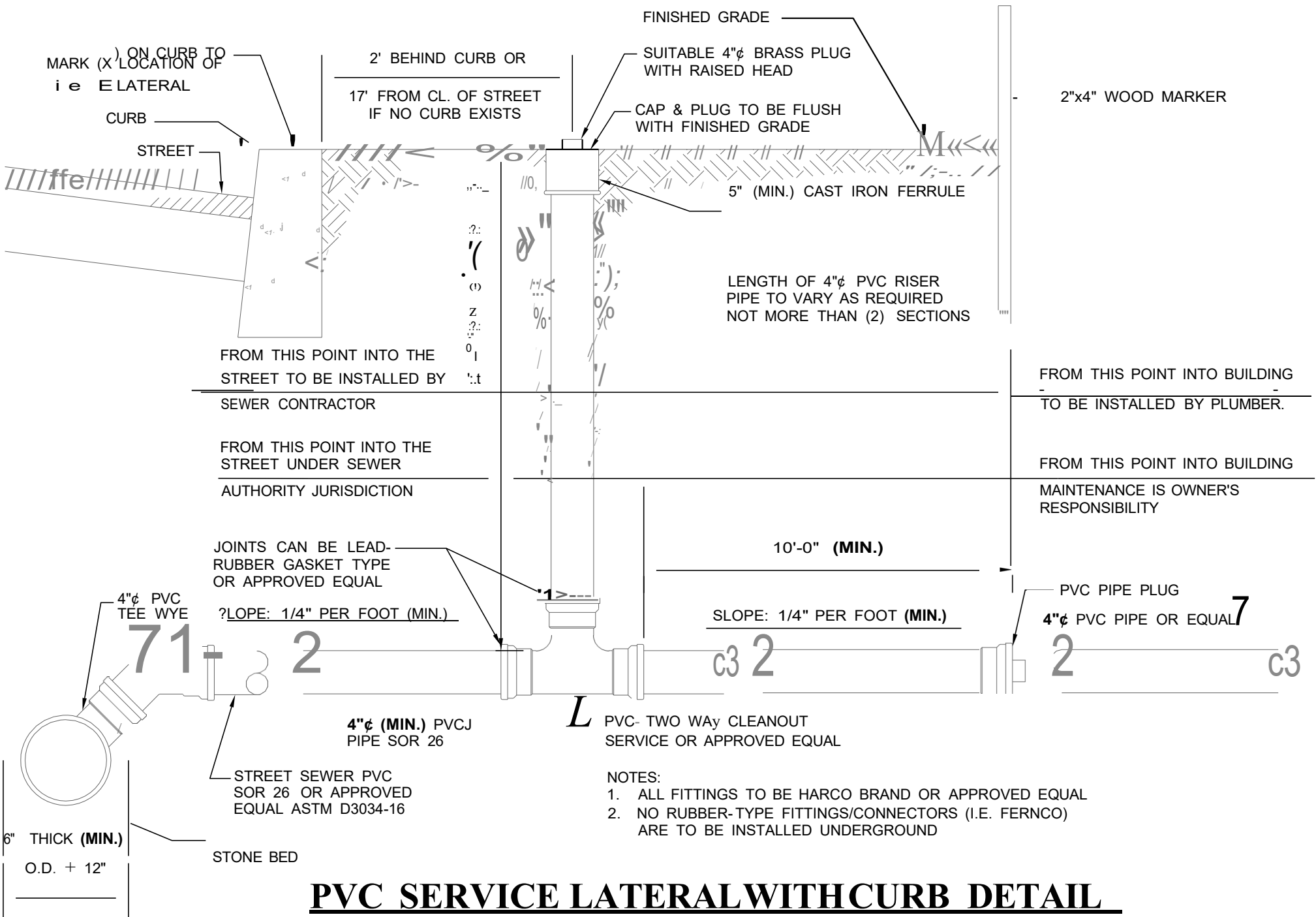

# PVC SERVICE LATERAL WITH CURB DETAIL

MONROE MUNICIPAL UTILITIES AUTHORITY  
 BY: J BRYSON & YATES  
 CONSULTING ENGINEERS, LLC  
 DATE: 3/24 SS-1  
 N.T.S.

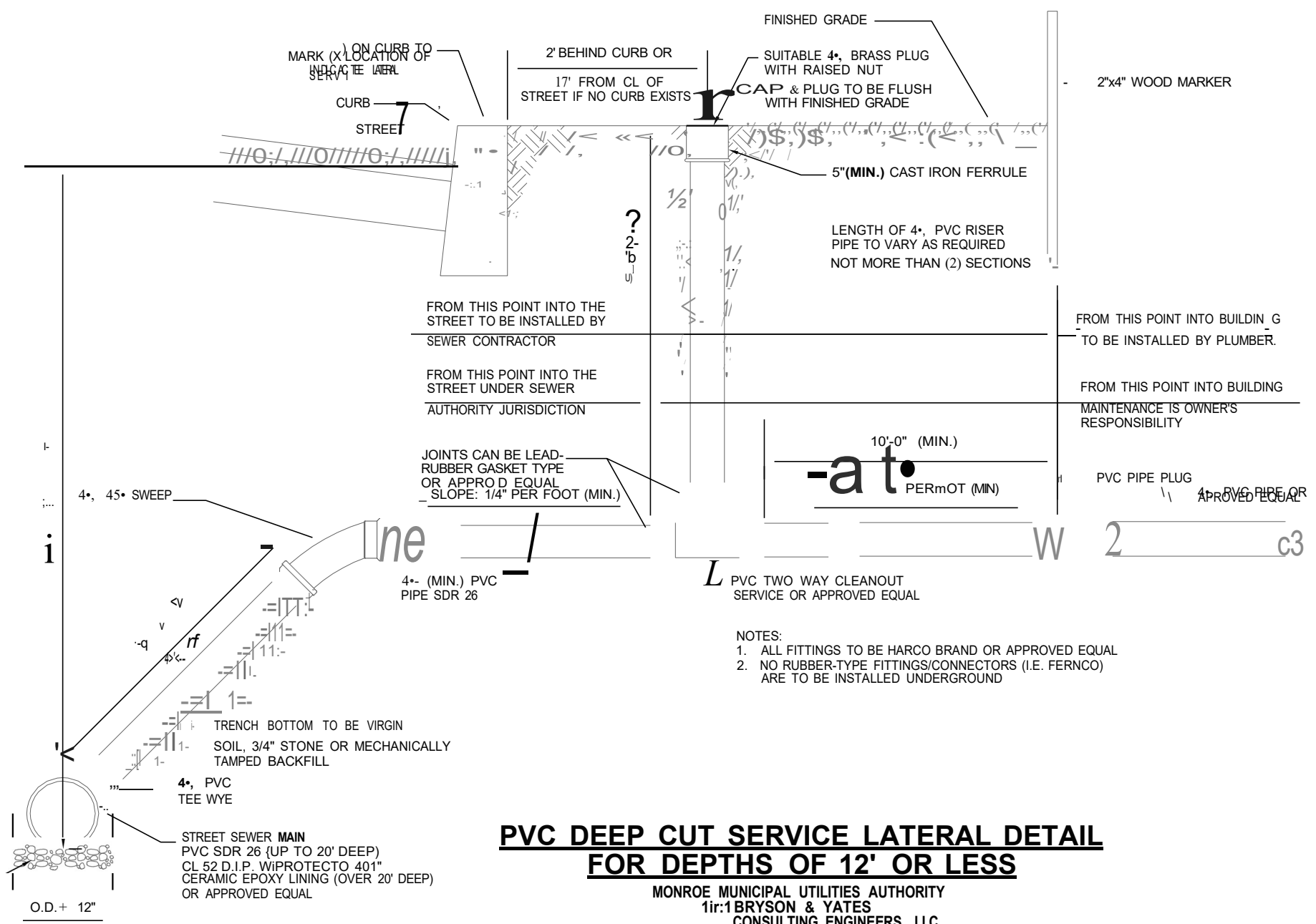

- NOTES:
1. ALL FITTINGS TO BE HARCO BRAND OR APPROVED EQUAL
  2. NO RUBBER-TYPE FITTINGS/CONNECTORS (I.E. FERNCO) ARE TO BE INSTALLED UNDERGROUND

**PVC DEEP CUT SERVICE LATERAL DETAIL**  
**FOR DEPTHS OF 12' OR LESS**

MONROE MUNICIPAL UTILITIES AUTHORITY  
 11:1 BRYSON & YATES  
 CONSULTING ENGINEERS, LLC  
 DATE: 3/24 SS 2  
 N.T.S.

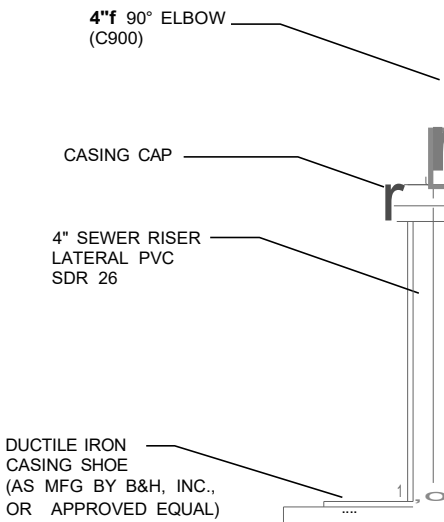
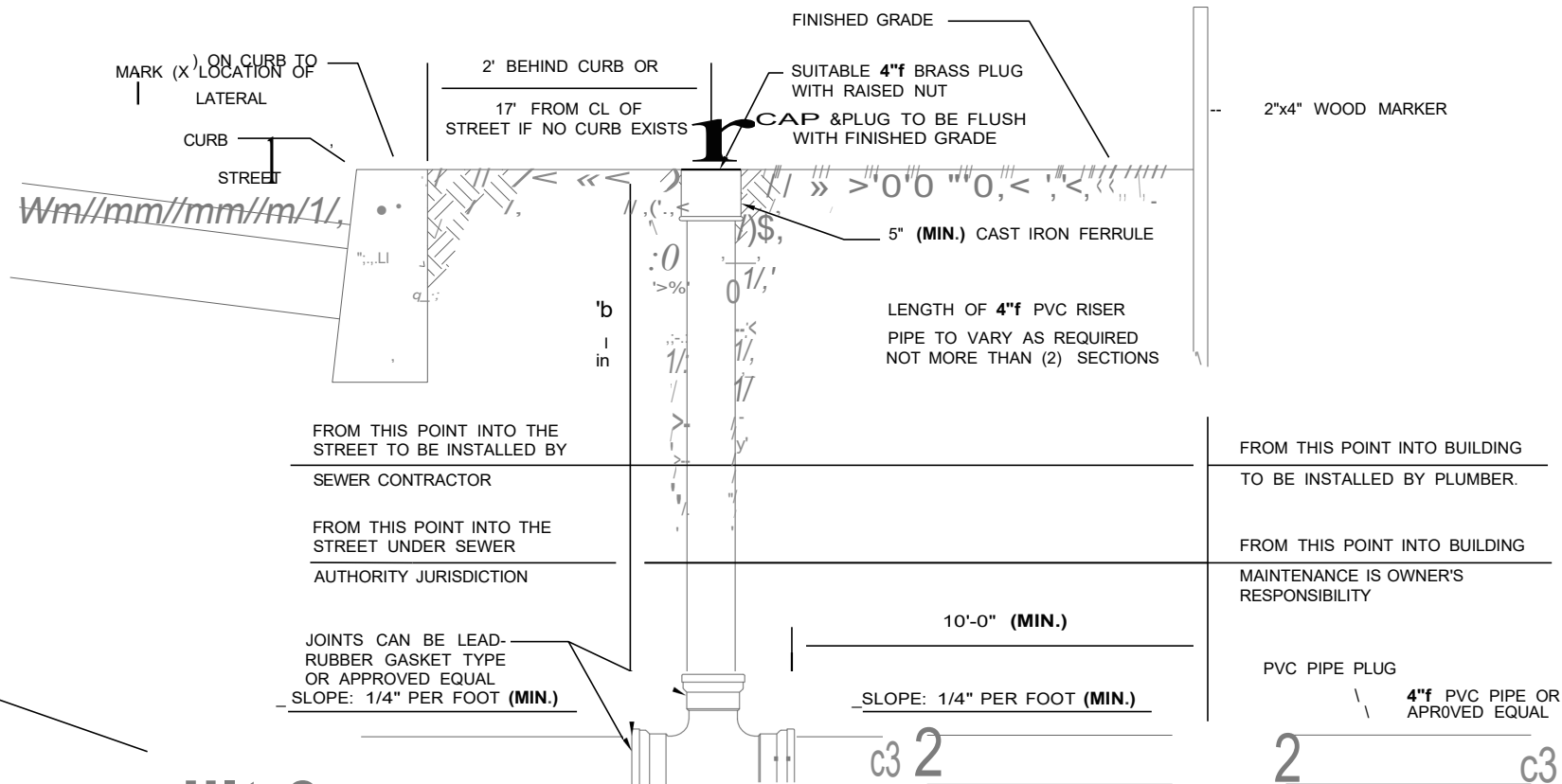

COMPACTED STONE BEDDING

FROM THIS POINT INTO THE STREET TO BE INSTALLED BY SEWER CONTRACTOR

FROM THIS POINT INTO THE STREET UNDER SEWER AUTHORITY JURISDICTION

FROM THIS POINT INTO BUILDING TO BE INSTALLED BY PLUMBER.

FROM THIS POINT INTO BUILDING MAINTENANCE IS OWNER'S RESPONSIBILITY

JOINTS CAN BE LEAD-RUBBER GASKET TYPE OR APPROVED EQUAL

SLOPE: 1/4" PER FOOT (MIN.)

10'-0" (MIN.)

SLOPE: 1/4" PER FOOT (MIN.)

PVC PIPE PLUG

4" f PVC PIPE OR APPROVED EQUAL

SEWER LATERAL / PVC SDR 26

PVC TWO WAY CLEANOUT SERVICE OR APPROVED EQUAL

8" f CASING PIPE (C900) AS MANUFACTURED BY BATES & HARRINGTON OR APPROVED EQUAL

STREET SEWER MAIN

PVC SDR 26 (UP TO 20' DEEP) CL 52 D.I.P. W/"PROTECTO 401" CERAMIC EPOXY LINING (OVER 20' DEEP) OR APPROVED EQUAL

- NOTES:
1. ALL FITTINGS TO BE BATES & HARRINGTON, INC. AND HARGO BRAND OR APPROVED EQUAL
  2. NO RUBBER-TYPE FITTINGS/CONNECTORS (I.E. FERNCO) ARE TO BE INSTALLED UNDERGROUND

## PVC DEEP CUT SERVICE LATERAL DETAIL FOR DEPTHS 12' OR MORE W/VERTICAL RISER

MONROE MUNICIPAL UTILITIES AUTHORITY  
HID BRYSON & YALES

CONSULTING ENGINEERS, LLC

DATE: 3/24 SS J  
N.T.S.

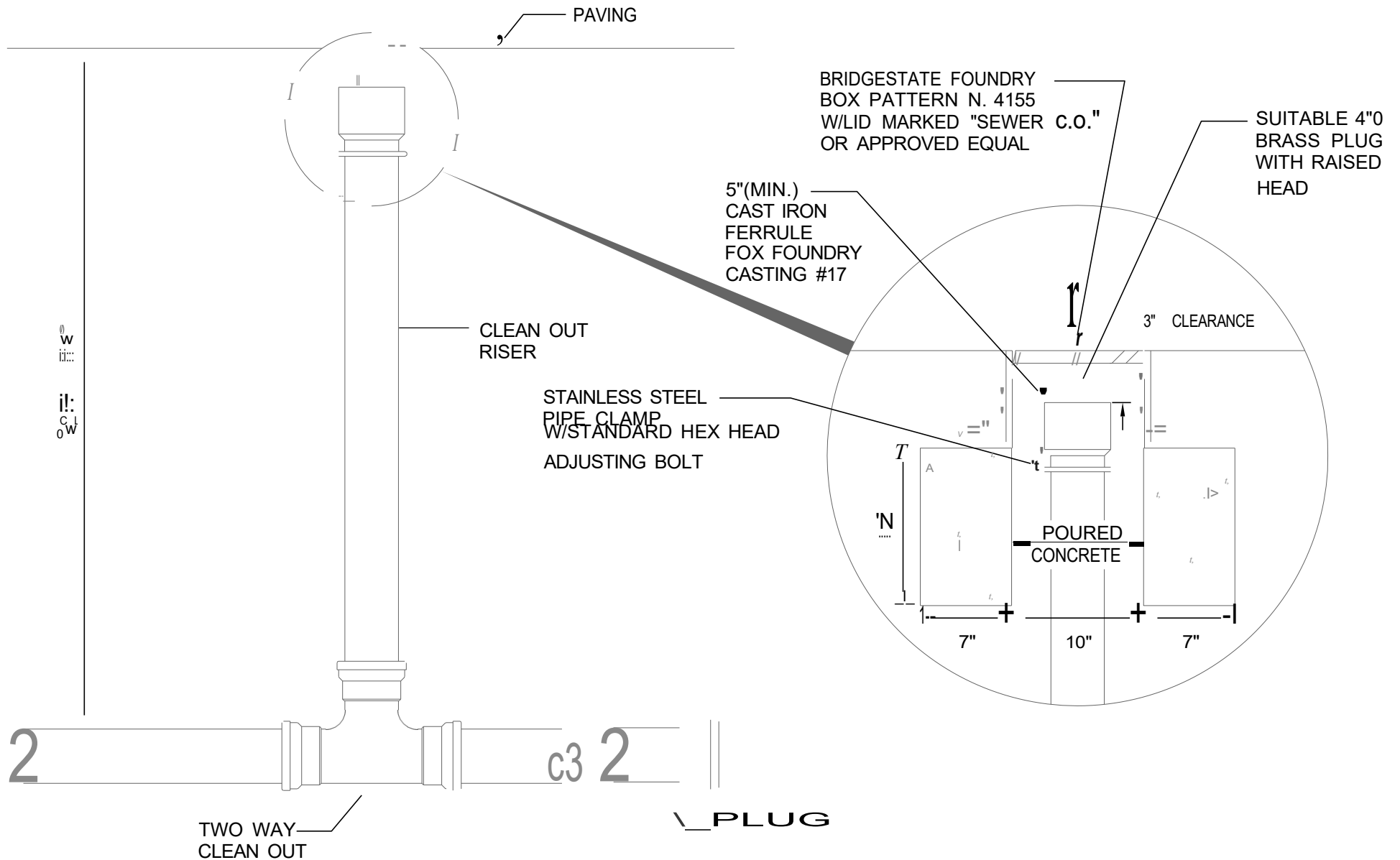

## TRAFFIC PROTECTOR CLEAN-OUT DETAIL

MONROE MUNICIPAL UTILITIES AUTHORITY  
 BY BRYSON & YATES  
 CONSULTING ENGINEERS, LLC  
 DATE: 3/24 SS 4  
 N.T.S.

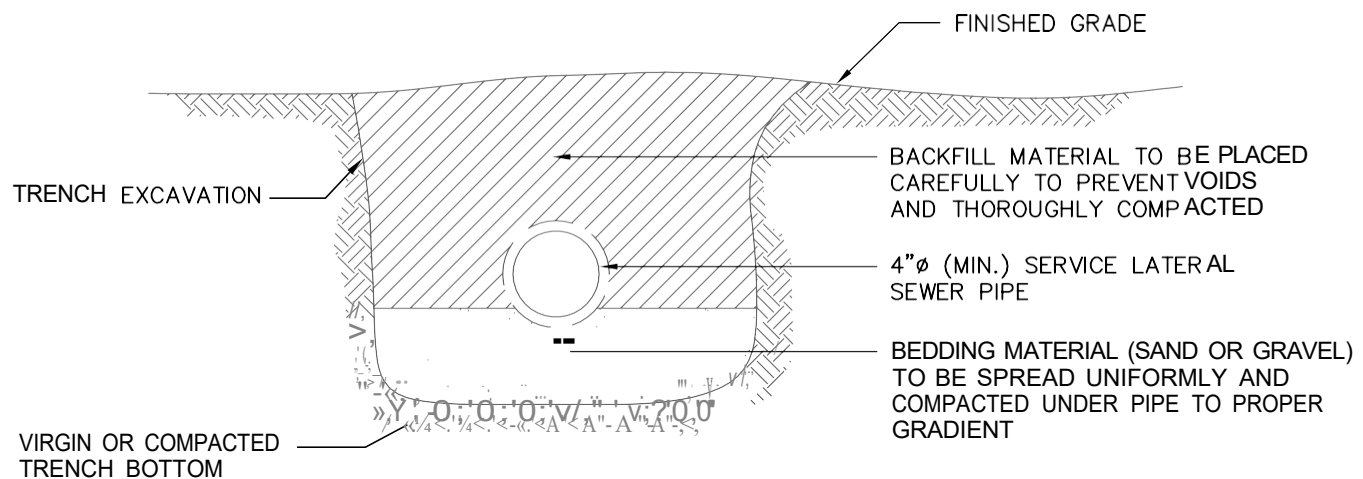

## **SERVICE LATERAL TRENCH DETAIL**

MONROE MUNICIPAL UTILITIES AUTHORITY  
 BRYSON & YATES  
 CONSULTING ENGINEERS, LLC  
 DATE: 3/24 SS-S  
 N.T.S.

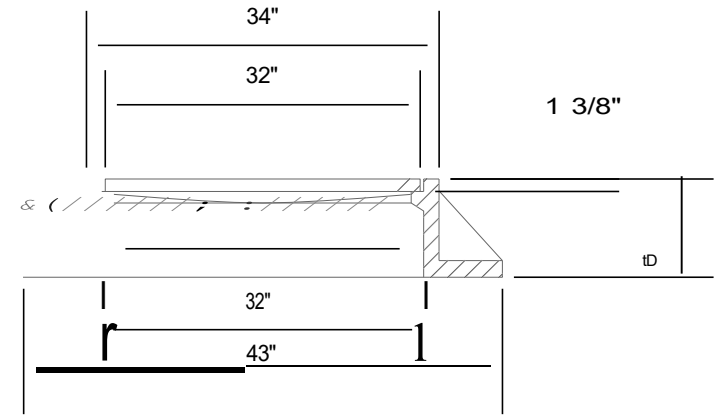
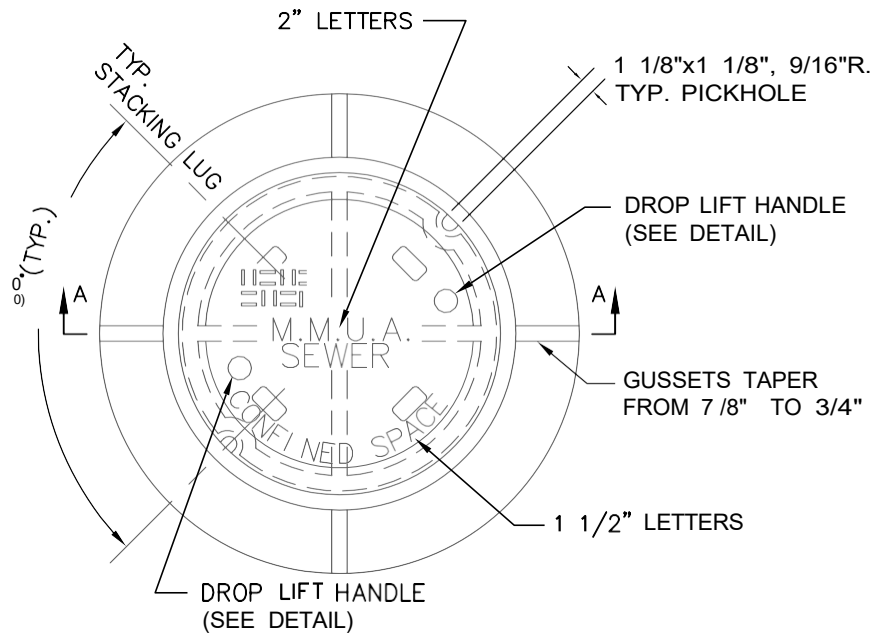

BRIDGESTATE MODEL #1012A (30")

NOTE:  
LOCKING LIDS ARE REQUIRED IN OFF-ROAD  
INSTALLATIONS. BRIDGESTATE MODEL NO. 1460A.

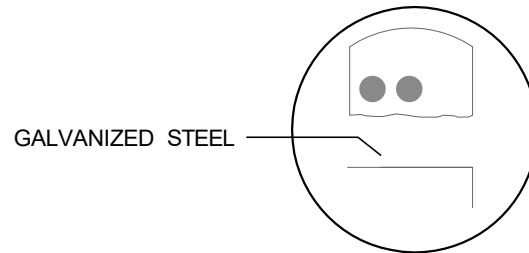

DROP LIFT HANDLE DETAIL

# MANHOLE COVER DETAIL

MONROE MUNICIPAL UTILITIES AUTHORITY  
 PREPARED BY: J BRYSON & YATES  
 CONSULTING ENGINEERS, LLC

DATE: 3/24  
 N.T.S.

SS S  
 -

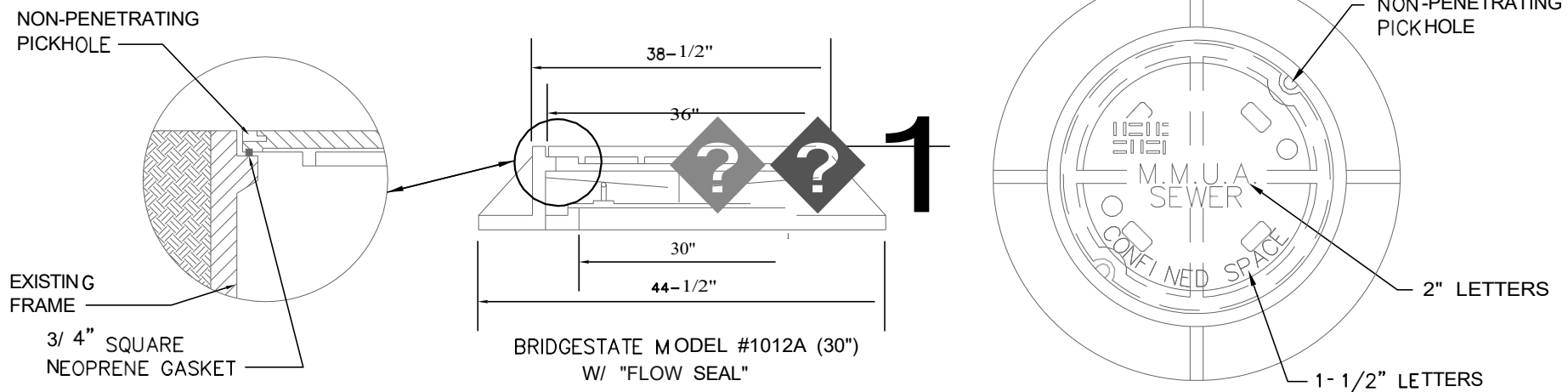

## WATERTIGHT MANHOLE COVER DETAIL

MONROE MUNICIPAL UTILITIES AUTHORITY  
 ffi: J BRYSON & YATES  
 CONSULTING ENGINEERS, LLC  
 DATE: 3/24 SS 7  
 N.T.S. -

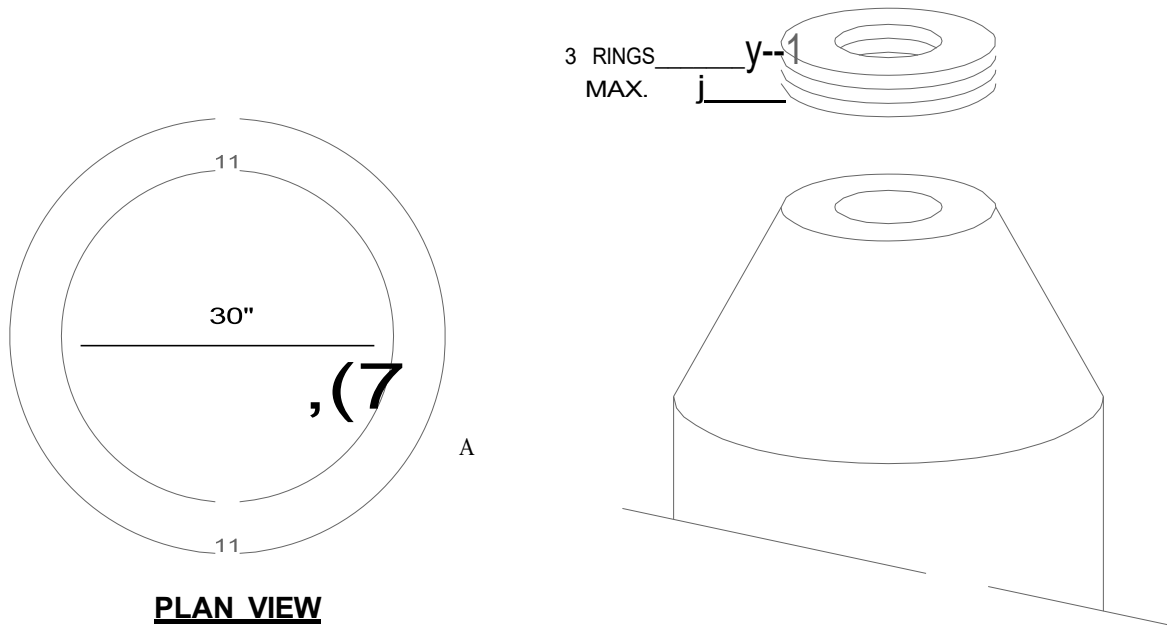

**PLAN VIEW**

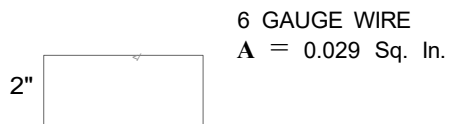

**SECT AA**

**SPECIFICATIONS:**

1. CONCRETE IS DESIGNED TO OBTAIN A STRENGTH OF 4000 PSI IN 28 DAYS.
2. DESIGN MEETS REQUIREMENTS OF A.S.T.M. STANDARD C478-22.
3. WEIGHT OF ONE PIECE (1/2 CIRCLE) 30" DIA. - 165 LBS.

# **STANDARD MANHOLE GRADE RING DETAIL**

MONROE MUNICIPAL UTILITIES AUTHORITY  
 BY BRYSON & YATES  
 CONSULTING ENGINEERS, LLC

DATE: 3/24  
 N.T.S.

SS B  
 -

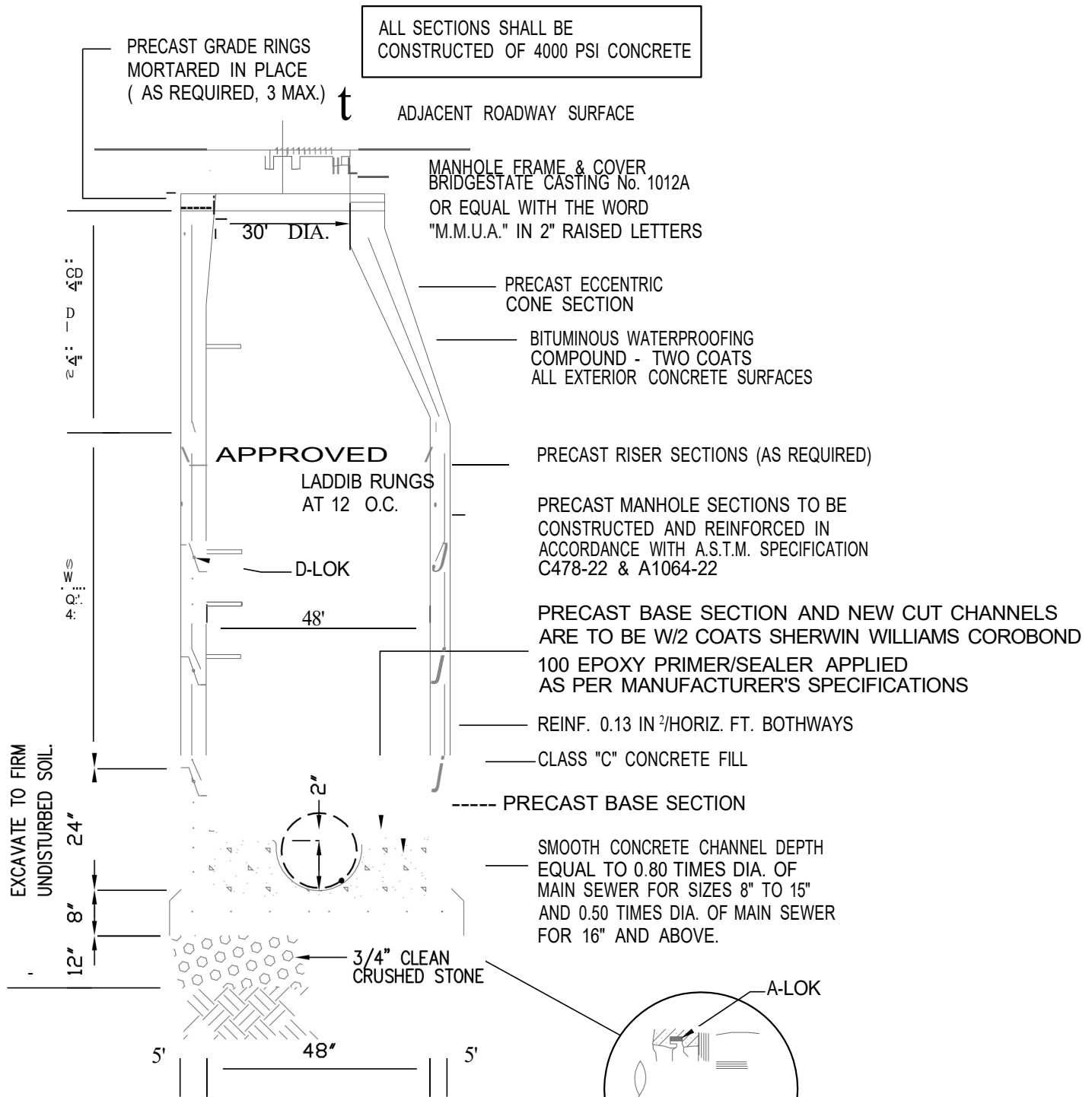

- NOTES:
1. THE USE OF EXTENSION RINGS FOR GRADE ADJUSTMENT WILL NOT BE PERMITTED.
  2. PRECAST MANHOLES SHALL BE CONSTRUCTED IN ACCORDANCE WITH ASTM C478-22.

# PRECAST MANHOLE DETAIL

MONROE MUNICIPAL UTILITIES AUTHORITY  
 11:CI BRYSON & YATES  
 CONSULTING ENGINEERS, LLC  
 DATE: 3/24 SS g  
 N.T.S. -

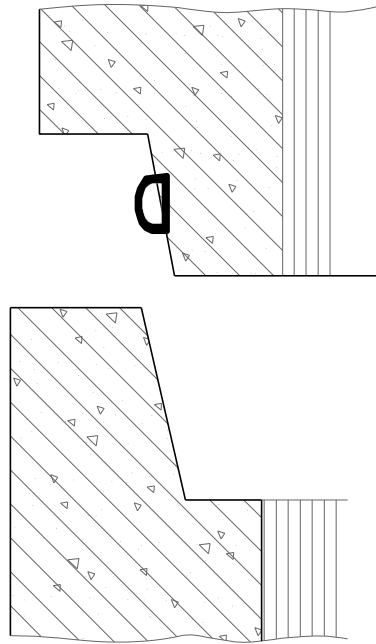

SECTION VIEW OF  
OPEN JOINT

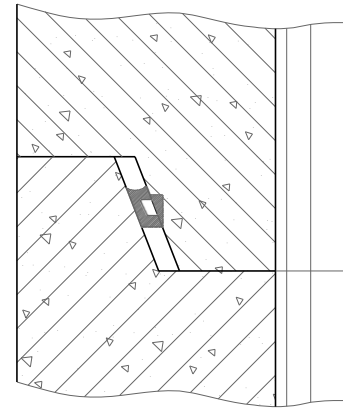

SECTION VIEW OF  
COUPLED JOINT

## OK JOINT GASKET DETAIL

MONROE MUNICIPAL UTILITIES AUTHORITY  
rL BRYSON & YATES  
CONSULTING ENGINEERS, LLC

DATE: 3/24 SS-1Q  
N.T.S.

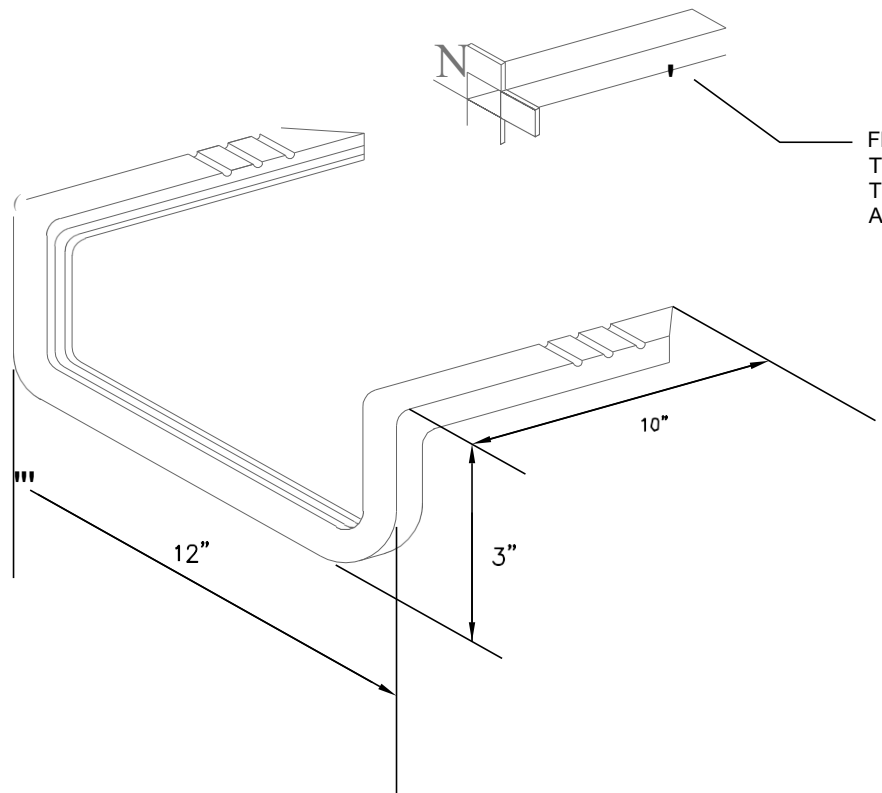

FLEX LOCK PLASTIC STEP INSERT.  
 THE INSERT IS CAST AS AN INTEGRAL PART OF  
 THE MANHOLE WALL TO PREVENT CORROSIVE  
 ACTION BETWEEN THE CONCRETE AND ALUMINUM

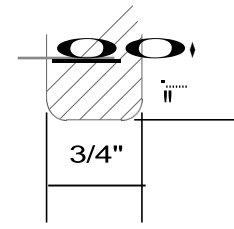

TYPICAL SECTION

- NOTES:
1. MATERIAL - ALUMINUM TYPE 6061-T6.
  2. MEETS OSHA REQUIREMENTS.
  3. GROOVES PROVIDE SAFE TREAD.

## DROP FRONT ALUMINUM RUNG DETAIL

MONROE MUNICIPAL UTILITIES AUTHORITY  
 BRYSON & YATES  
 CONSULTING ENGINEERS, LLC  
 DATE: 3/24  
 N.T.S. 55-11

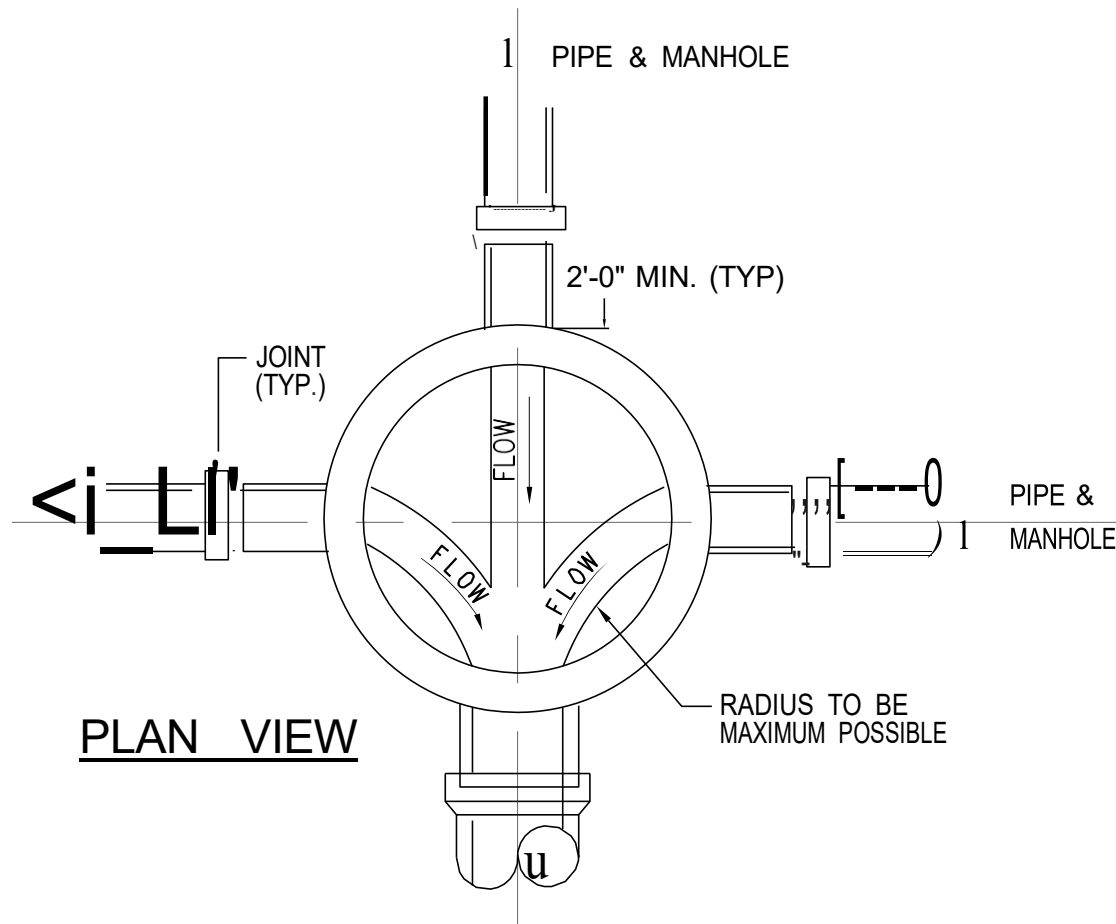

## TYPICAL CHANNELING OF MANHOLE BOTTOM

MONROE MUNICIPAL UTILITIES AUTHORITY

BYRON & YATES

CONSULTING ENGINEERS, LLC

DATE: 3/24

SS-12

N.T.S.

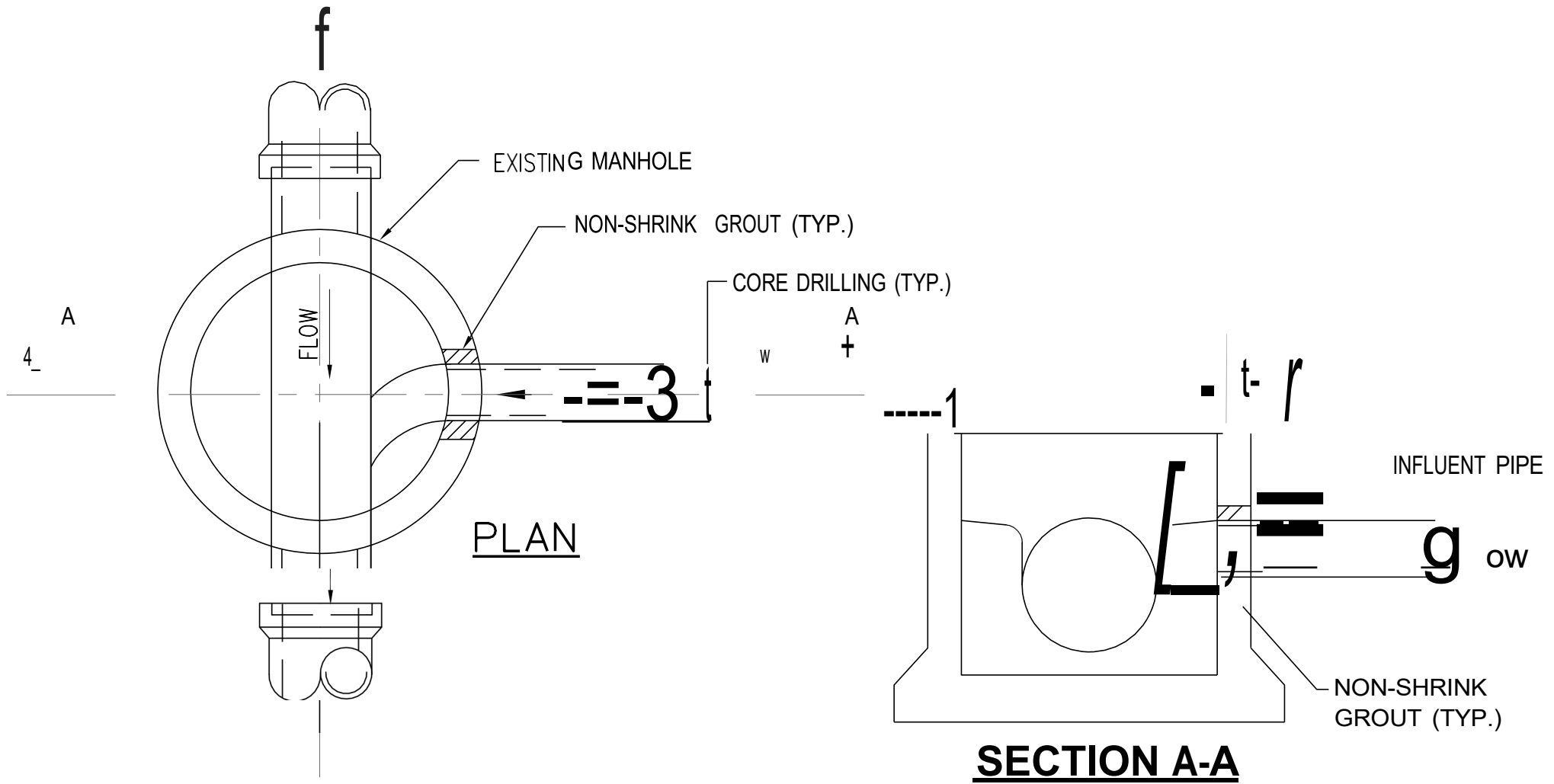

1. THE CONNECTION TO THE EXISTING MANHOLE SHOULD BE MADE WITH A CORING MACHINE.
2. THE ANNULAR SPACE SHOULD BE FILLED WITH NON-SHRINK GROUT.
3. THE BENCH CHANNEL SHOULD BE CAREFULLY JACKHAMMERED TO ACCOMMODATE THE SEWER CONNECTION.
4. EPOXY GROUT EQUIVALENT TO SIKA-DUR HI MOD WITH AGGREGATE OR SIKA-DUR LO MOD SHOULD BE USED TO FORM THE NEW CHANNEL.
5. A PIPE JOINT SHOULD BE PROVIDED WITHIN FOUR (4) FEET OF THE MANHOLE TO ALLOW FOR DIFFERENTIAL SETTLEMENT.
6. THE CONTRACTOR SHALL BE RESPONSIBLE FOR ANY DAMAGES TO MANHOLE INTERCEPTOR, OR ADJACENT PROPERTY DUE TO CONNECTION CONSTRUCTION.
7. NEW CHANNELS ARE TO BE COATED WITH 2 COATS SHERWIN WILLIAMS COROBOND 100 EPOXY PRIMER/SEALER APPLIED AS PER MANUFACTURER'S SPECIFICATIONS.

## MANHOLE CORING DETAIL

MONROE MUNICIPAL UTILITIES AUTHORITY  
 BY: I BRYSON & YATES  
 CONSULTING ENGINEERS, LLC

DATE: 3/24  
 N.T.S.

SS-13

\* IF DIFFERENCE BETWEEN INVERTS IS LESS THAN 2.0' SLOPE  
 CONCRETE CHANNEL UNIFORMLY BETWEEN INFLOW AND OUTFLOW PIPES

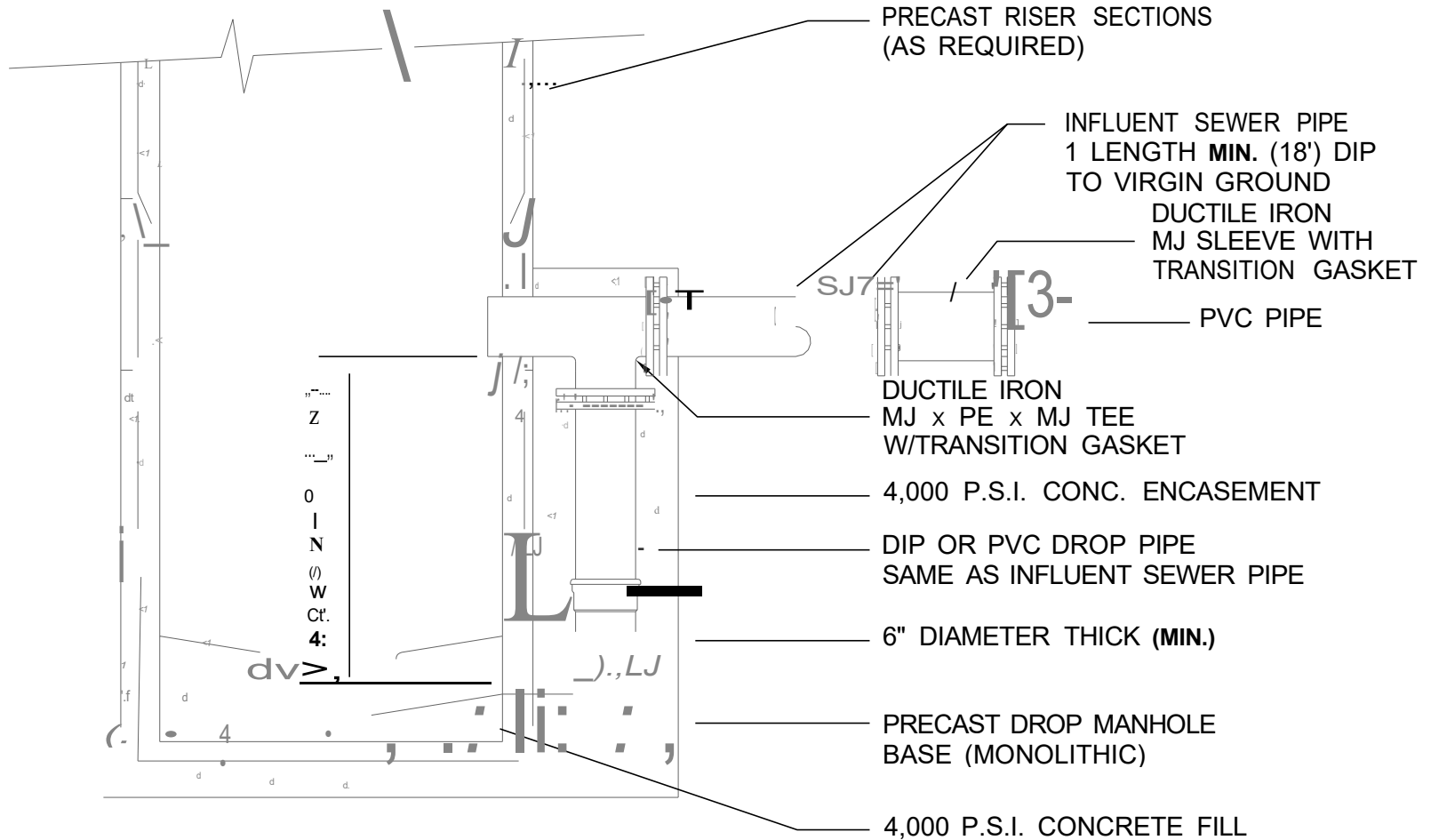

NOTE:  
 DETAILS NOT SHOWN ARE THE SAME  
 FOR STANDARD PRECAST MANHOLE

## **DROP MANHOLE DETAIL**

MONROE MUNICIPAL UTILITIES AUTHORITY  
 BY: BRYSON & YATES  
 CONSULTING ENGINEERS, LLC

DATE: 3/24  
 N.T.S.

SS-14

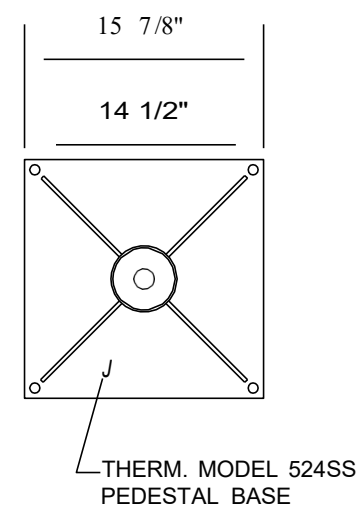
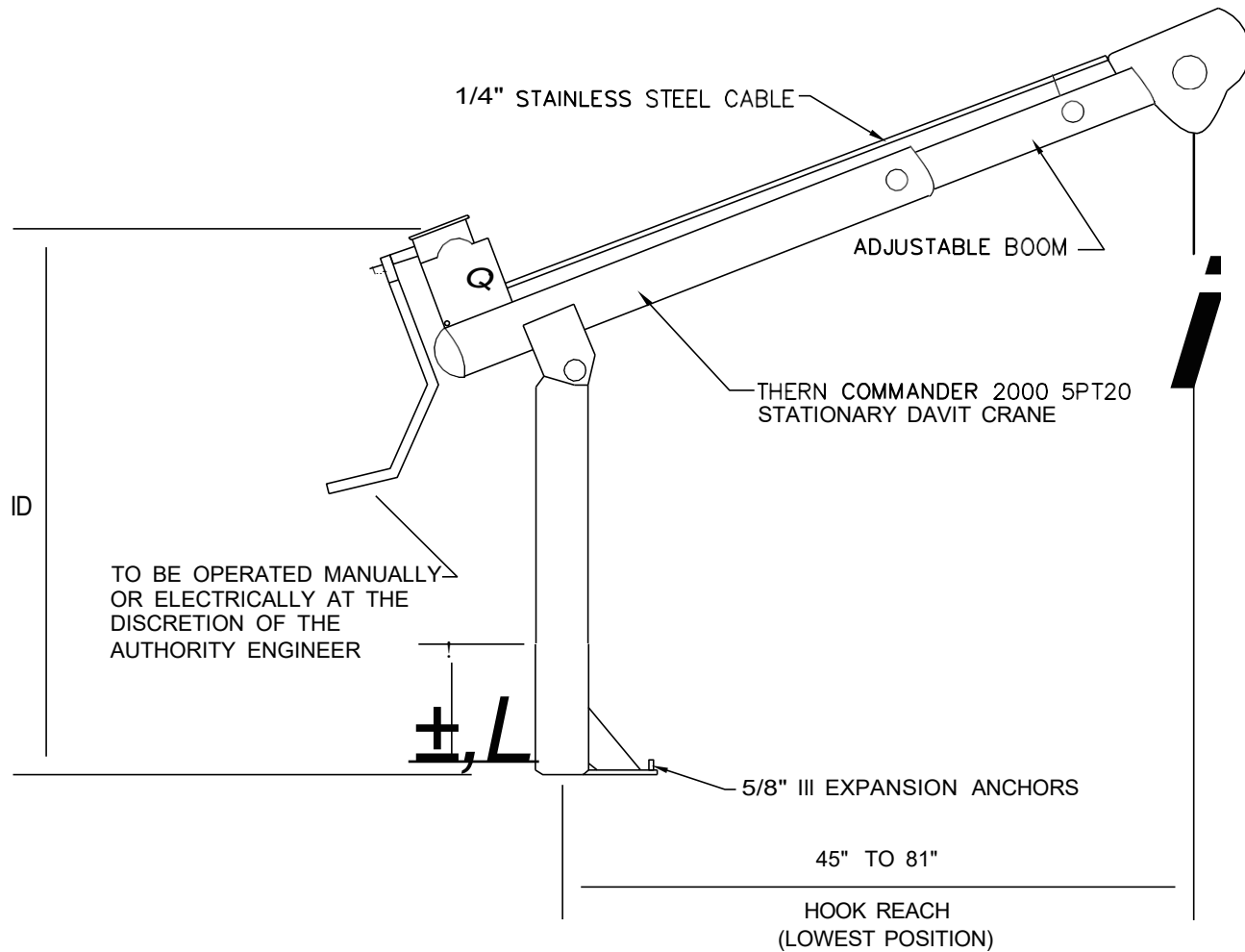

NOTE:  
THE DESIGN ENGINEER SHALL VERIFY LIFTING CAPACITY AND REACH FOR PUMPS AND MUFFIN MONSTER COMMUNUTOR.

## **LIFTING DAVIT DETAIL**

MONROE MUNICIPAL UTILITIES AUTHORITY  
BRYSON & YATES  
CONSULTING ENGINEERS, LLC

DATE: 3/24  
N.T.S.

SS-15

NOTES:

1. THE CONNECTION TO THE MANHOLE SHOULD BE MADE WITH A CORING MACHINE
2. THE ANNULAR SPACE SHOULD BE FILLED WITH NON-SHRINK GROUT.
3. A PIPE JOINT SHOULD BE PROVIDED WITHIN FOUR (4) FEET OF THE MANHOLE TO ALLOW FOR DIFFERENTIAL SETTLEMENT.
4. THE CONTRACTOR SHALL BE RESPONSIBLE FOR ANY DAMAGES TO MANHOLE INTERCEPTOR, OR ADJACENT PROPERTY DUE TO CONNECTION CONSTRUCTION.

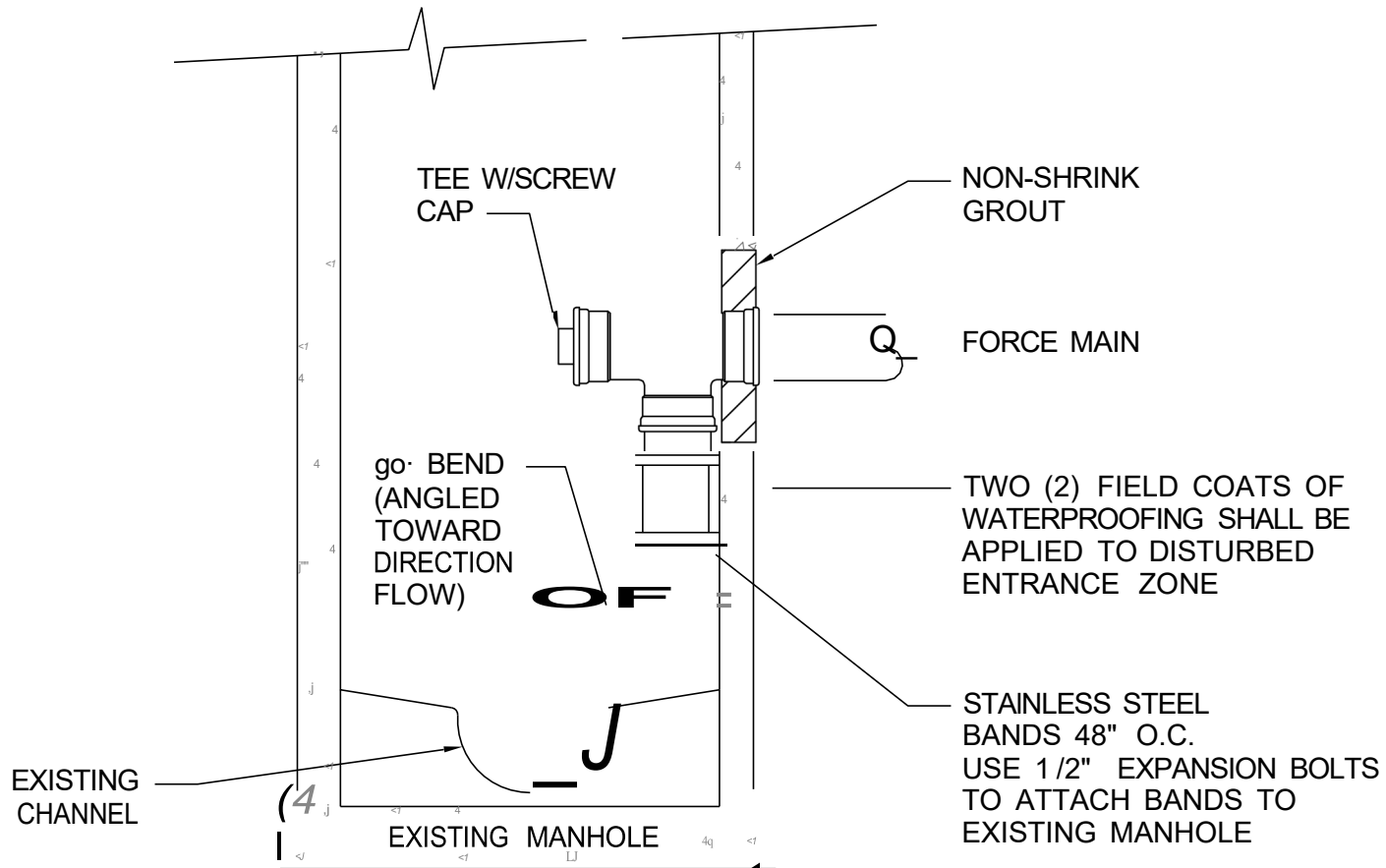

## **FORCE MAIN INSIDE DROP CONNECTION DETAIL**

MONROE MUNICIPAL UTILITIES AUTHORITY  
11:CI BRYSON & YATES  
CONSULTING ENGINEERS, LLC

DATE: 3/24  
N.T.S.

SS-1S

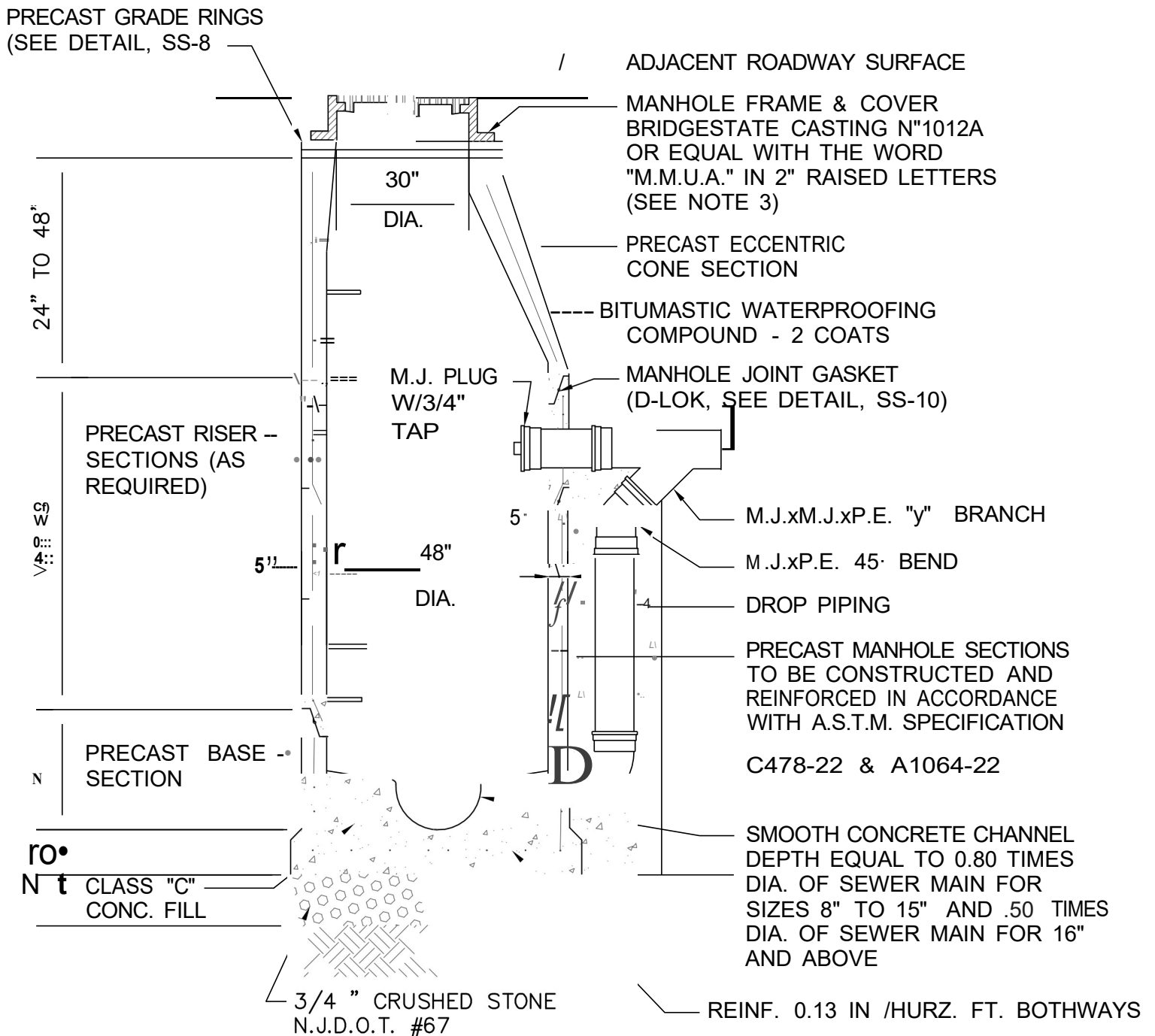

NOTES:

1. ALL D.I.P. FITTINGS EXCEPT VERTICAL DROP PIPING, TO BE FURNISHED WITH MEGA-LUG RESTRAINED JOINTS OR APPROVED EQUAL.
2. NEW CHANNELS ARE TO BE COATED WITH (2) COATS SHERWIN WILLIAMS COROBOND 100 EPOXY PRIMER/SEALER APPLIED AS PER MANUFACTURER'S SPECIFICATION.
3. THE USE OF EXTENSION RINGS FOR GRADE ADJUSTMENT WILL NOT BE PERMITTED.

## FORCE MAIN OUTSIDE DROP CONNECTION DETAIL

MONROE MUNICIPAL UTILITIES AUTHORITY  
rri'J BRYSON & YATES  
CONSULTING ENGINEERS, LLC

DATE: 3/24  
N.T.S.

SS-17

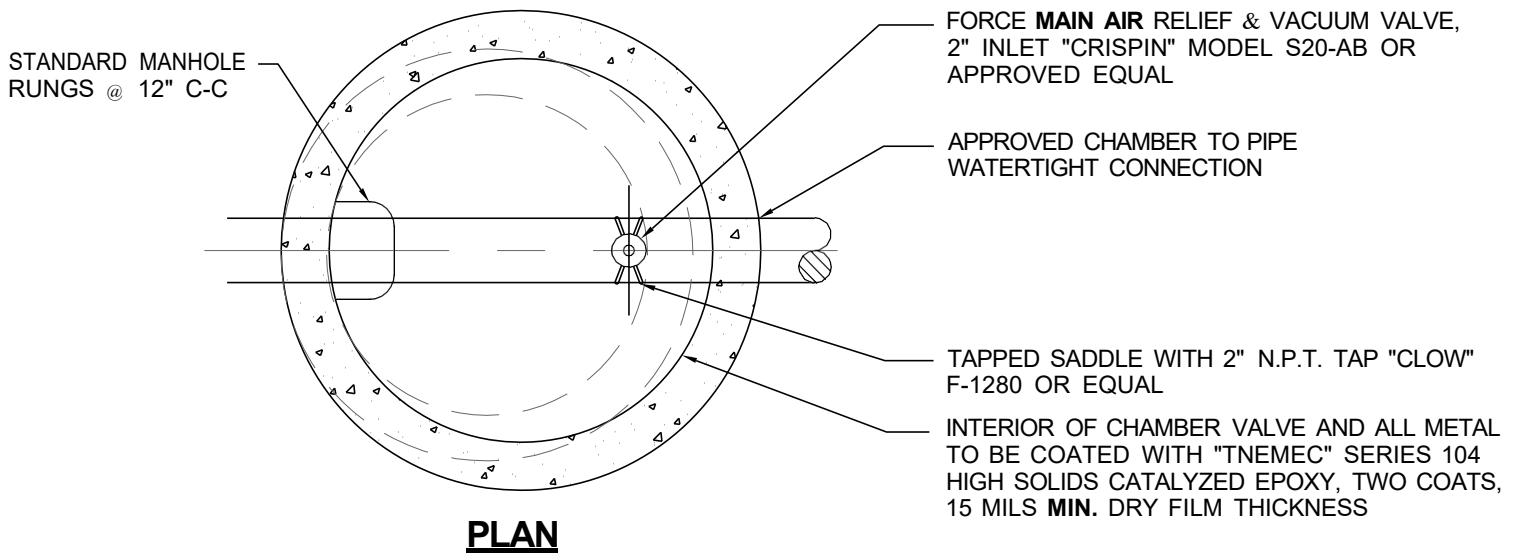

VALVE TO BE SET UNDER MANHOLE OPENING FOR EASY MAINTENANCE/REMOVAL. THE SPACE BETWEEN RUNGS & VALVE SHALL BE MAXIMIZED TO ALLOW ENTRY.

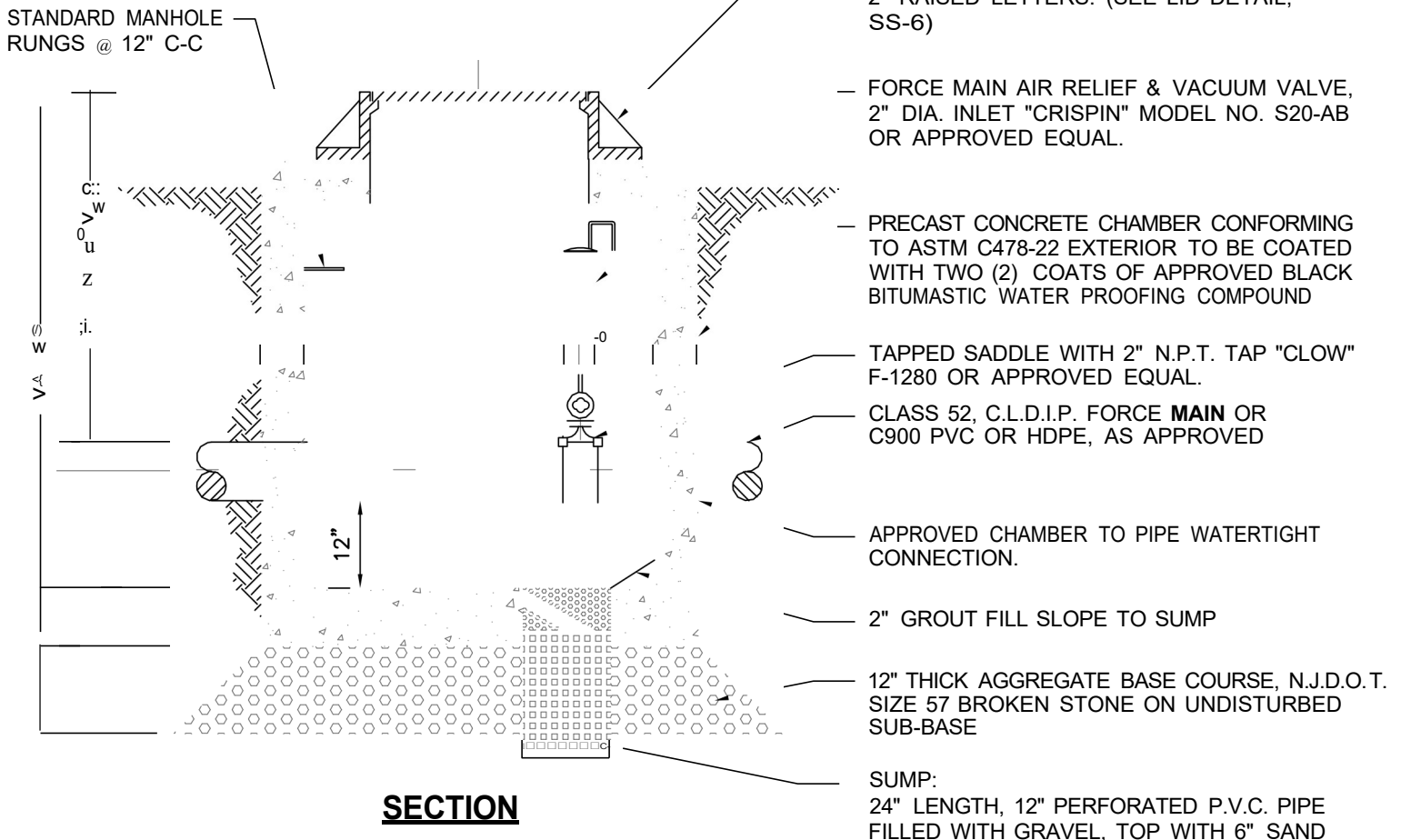

# FORCE MAIN AIR RELEASE AND VACUUM CHAMBER

MONROE MUNICIPAL UTILITIES AUTHORITY  
 rii:1 BRYSON & YAIES  
 CONSULTING ENGINEERS, LLC

DATE: 3/24  
 N.T.S.

SS-1B

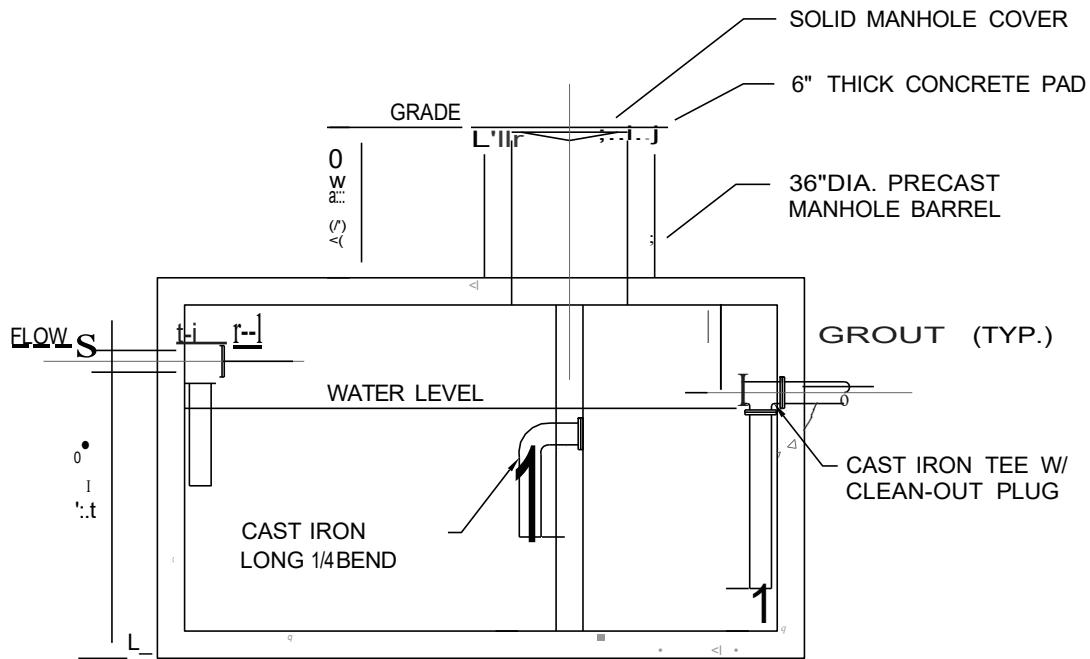

PLAN VIEW

PRECAST GREASE INTERCEPTOR TANK  
CONFORMING TO ASTM C1613-22

NOTE:  
GREASE TRAP IS TO BE SIZED IN ACCORDANCE  
WITH N.J.A.C. CHAPTER 9A SEC 7:9A-8.1

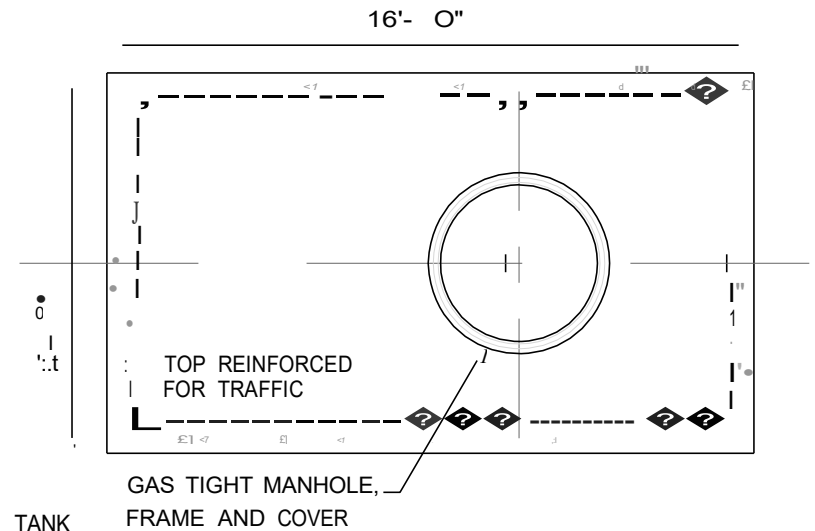

TOP VIEW

## GREASE TRAP DETAIL

MONROE MUNICIPAL UTILITIES AUTHORITY  
1 BRYSON & YATES  
CONSULTING ENGINEERS, LLC

DATE: 3/24  
N.T.S.

SS-19

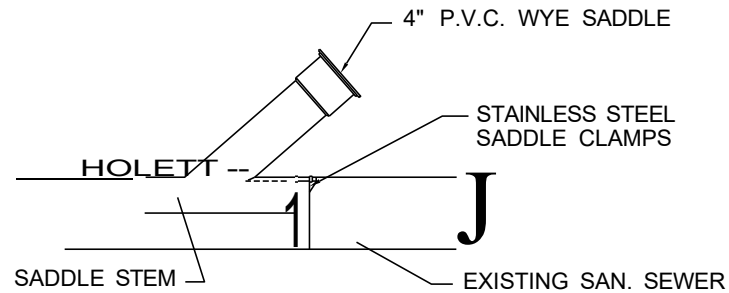

NOTE:  
THE P.V.C. SADDLE CONNECTION SHALL BE MADE AS DESCRIBED BELOW.

**GASKET1**

1. CUT HOLE IN EXISTING SANITARY SEWER 1/4' LARGER THAN THE O.D. OF SADDLE STEM; DOWNSTREAM SIDE TO BE CUT AT 45° TO ALLOW SADDLE STEM FIT.
2. MAKE SURE BOTH SURFACES ARE CLEAN.
3. APPLY GASKET.
4. POSITION SADDLE OVER HOLE.
5. TIGHTEN STAINLESS STEEL SADDLE CLAMPS.

## **SANITARY SEWER SADDLE CONNECTION FOR 4" LATERAL CONNECTION INTO EXISTING SANITARY SEWER**

MONROE MUNICIPAL UTILITIES AUTHORITY  
R. J. BRYSON & YATES  
CONSULTING ENGINEERS, LLC

DATE: 3/24  
N.T.S.

**SS-20**



BROOM FINISH WHILE SURFACE IS STILL PLASTIC, PROVIDE A TEXTURED FINISH BY DRAWING A FIBER BRISTLE BROOM UNIFORMLY OVER THE SURFACE. PROVIDE THE TEXTURING IN ONE DIRECTION ONLY. PROVIDE LIGHT TEXTURING TO BE CONSISTENT WITH ADJOINING SIDEWALK FINISH. METER PIT LID, CURB BOX AND CONCRETE PAD TO BE FLUSH BETWEEN CURB AND SIDEWALK.

TYLER TYPE 6500 SERIES-SCREW TYPE. CURB BOX-93E(36"- 54") COMPLETE WITH LID MARKED "WATER"  
 NOTE: FOR LARGER THAN 1" UP TO 2" SERVICE USE MUELLER TYPE H10350 WITH ENLARGED BASE.

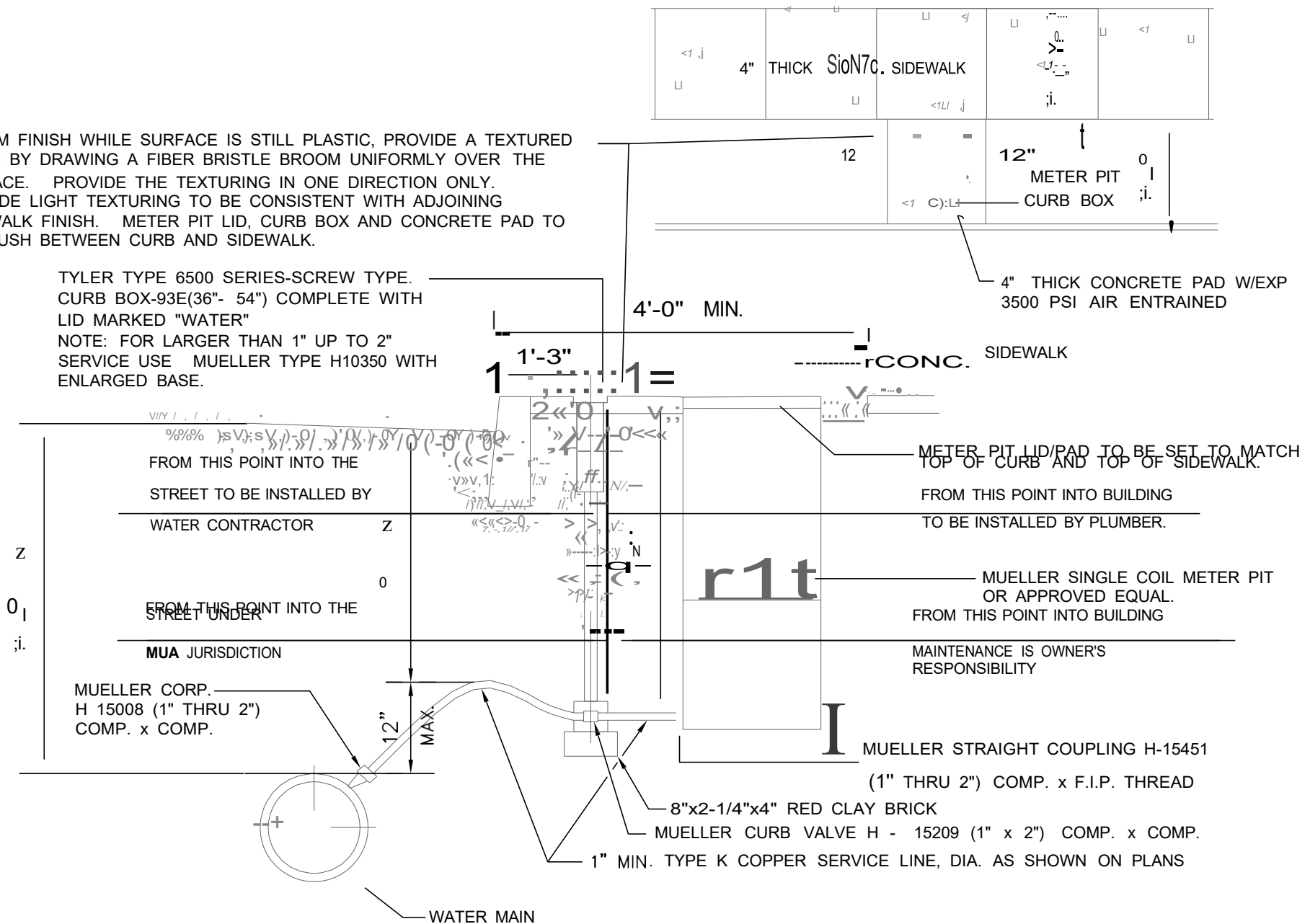

# WATER SERVICE WITH CONCRETE CURB

MONROE MUNICIPAL UTILITIES AUTHORITY  
 BRYSON & YATES  
 CONSULTING ENGINEERS, LLC  
 DATE: 3/24  
 N.T.S.

**NOTE:** CURB BOX TO BE TYLER - 6500 SERIES SCREW TYPE CURB BOX-93E (36"-54") COMPLETE WITH LID MARKED "WATER"  
**NOTE:** FOR LARGER THAN 1 1/4 UP TO 2" SERVICE USE TYLER TYPE HI0350 ENLARGED BASE.

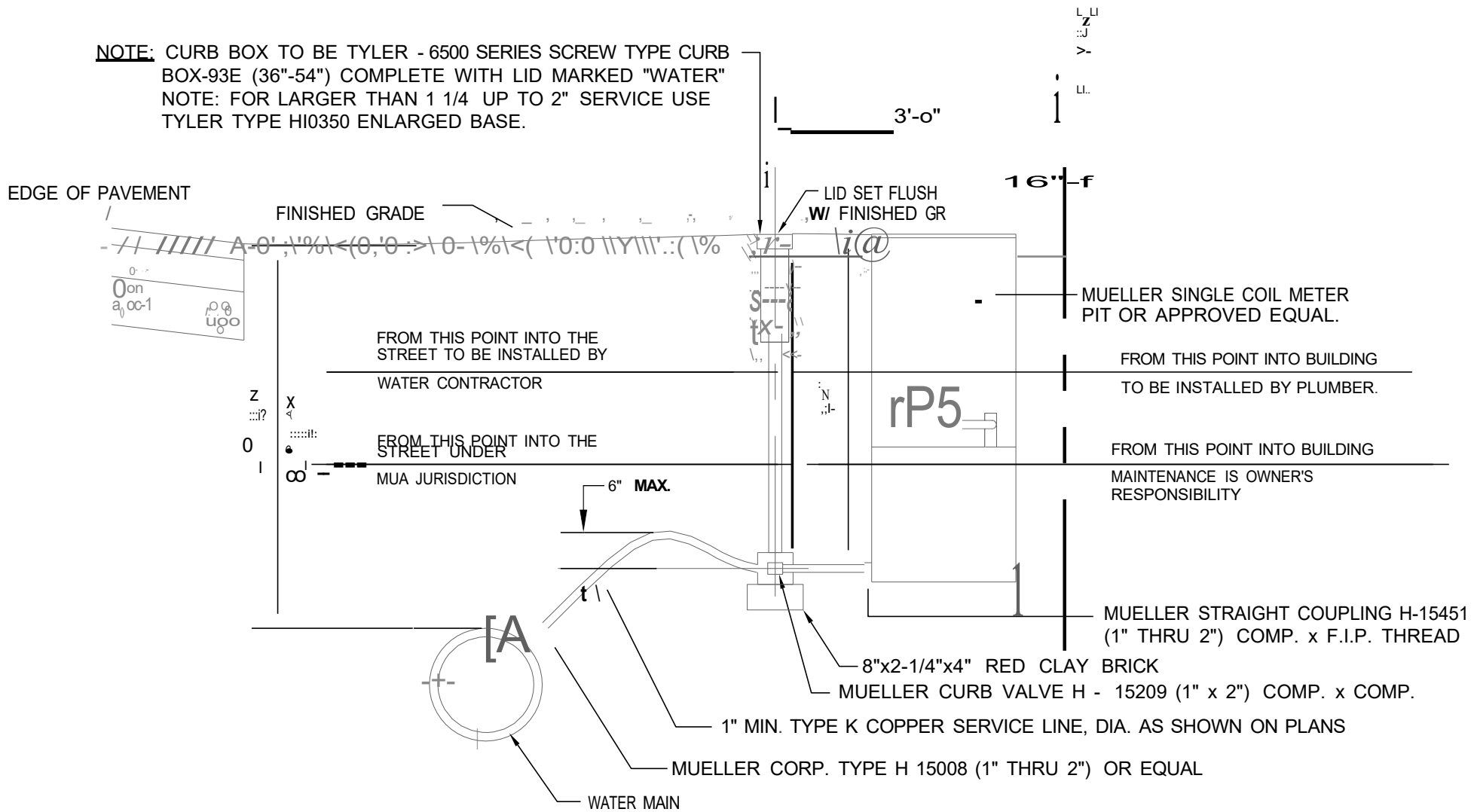

## WATER SERVICE WITHOUT CONCRETE CURB

MONROE MUNICIPAL UTILITIES AUTHORITY  
 BRYSON & YATES  
 CONSULTING ENGINEERS, LLC  
 DATE: 3/24  
 N.T.S.

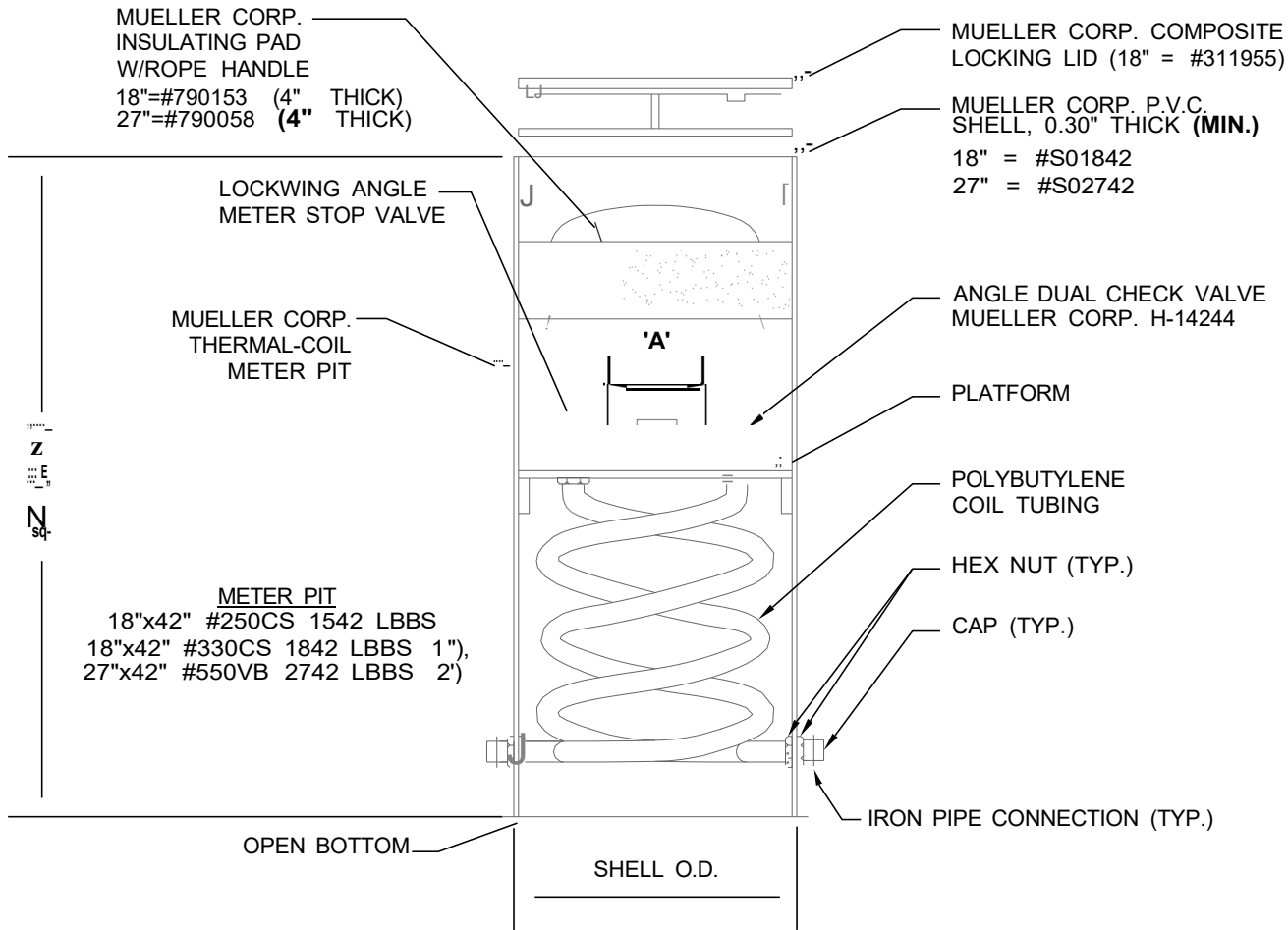

METER SIZE	'A'	METER PIT TYPE
1"	11.125"	THERMAL COIL
2"	17.25"	THERMAL COIL

PAVED OR CONCRETE SURFACE-FRAME # 700098-1

NOTE:  
ADJUSTA-COIL METER PIT MAY BE USED WITH MMUA APPROVAL.

# THERMALCOIL METER PIT

MONROE MUNICIPAL UTILITIES AUTHORITY  
iD BRYSON & YATES  
CONSULTING ENGINEERS, LLC

DATE: 3/24  
N.T.S.

W  
- 3

MUELLER A423 SUPER CENTURION FIRE HYDRANT OR APPROVED EQUAL WITH TWO 2-1/2" HOSE NOZZLES, ONE 4-1/2" PUMPER CONNECTION, 1-1/2" PENTAGONAL OPERATING NUT AND 6" M.J. ELBOW

NOTE:  
BROOM FINISH WHILE SURFACE IS STILL PLASTIC, PROVIDE A TEXTURED FINISH BY DRAWING A FIBER BRISTLE BROOM UNIFORMLY OVER THE SURFACE. PROVIDE THE TEXTURING IN ONE DIRECTION ONLY. PROVIDE LIGHT TEXTURING TO BE CONSISTENT WITH ADJOINING SIDEWALK FINISH.

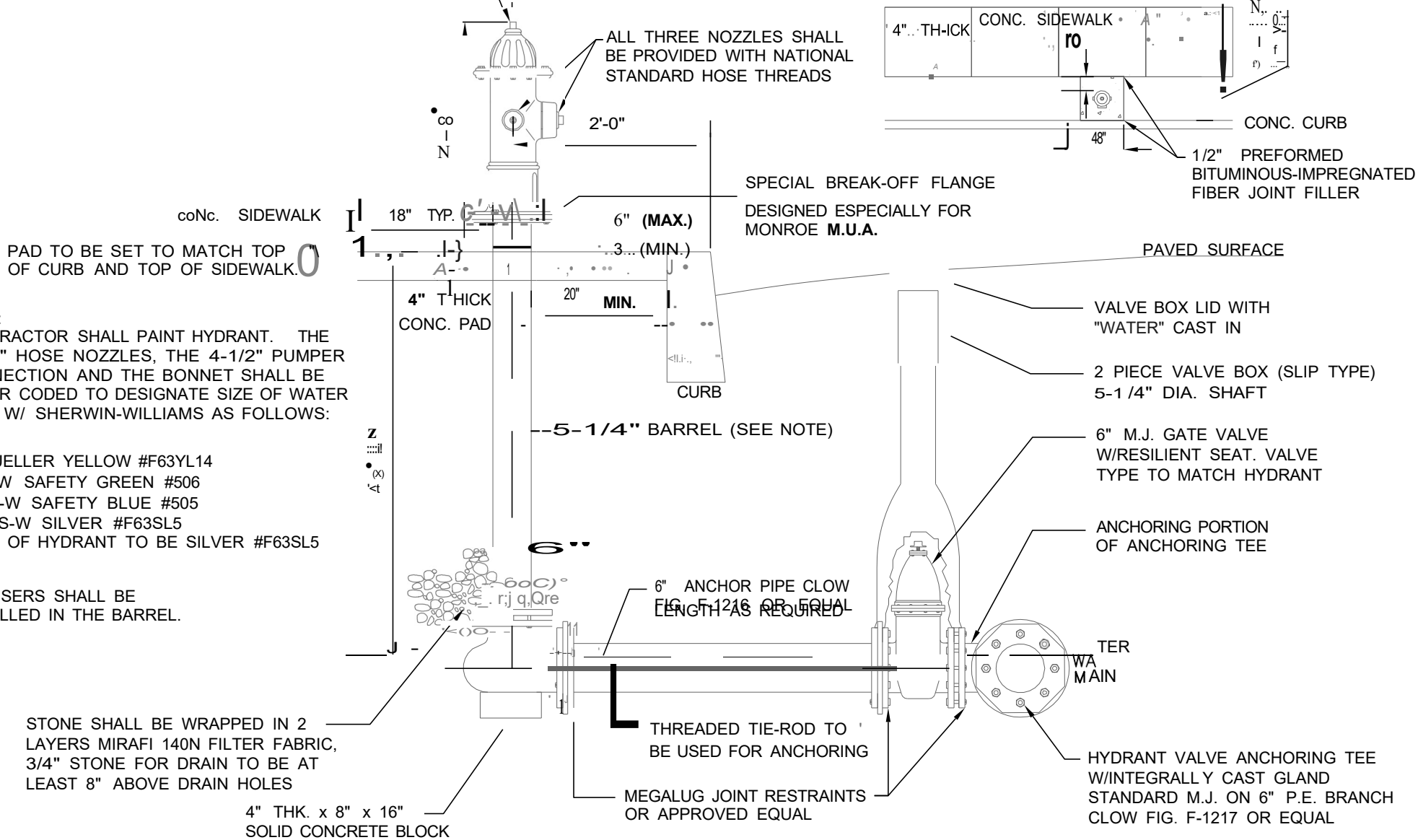

## FIRE HYDRANT WITH CURB DETAIL

MONROE MUNICIPAL UTILITIES AUTHORITY  
li: D BRYSON & YATES  
CONSULTING ENGINEERS, LLC

DATE: 3/24  
N.T.S.

W  
- 4



## WATER MAIN PIPE JOINT RESTRAINT TABLES

### JOINT RESTRAINTS AT BENDS & DEAD-ENDS

DEGREE OF BEND	6" PIPE	8" PIPE	10" PIPE	12" PIPE	16" PIPE
11 1/4°	5'	5'	5'	5'	5'
22 1/2°	5'	5'	5'	5'	10'
45°	5'	10'	10'	10'	15'
90°	15'	20'	20'	25'	30'
<b>DEAD-END</b>	25'	30'	35'	40'	55'

MINIMUM LENGTH OF PIPE TO BE RESTRAINED IN EACH DIRECTION FROM CENTER OF BEND

### JOINT RESTRAINTS AT TEES

MAIN RUN PIPE SIZE	6" BRANCH	8" BRANCH	10" BRANCH	12" BRANCH	16" BRANCH
6"	10'				
8"	10'	20'			
10"	5'	15'	25'		
12"	5'	10'	20'	30'	
16"	5'	5'	15'	25'	40'

### JOINT RESTRAINTS AT REDUCERS

MAIN RUN PIPE SIZE	6" REDUCTION	8" REDUCTION	10" REDUCTION	12" REDUCTION
8"	15'			
10"	25'	15'		
12"	30'	25'	15'	
16"	N/A	N/A	N/A	25'

Fitting Type	Pipe Material	Soil Type	Safety Factor	Trench Type	Depth of Bury	Test Pressure	Nominal Size	Bend Angle	Branch Size	Length Along Run	Reduced Size	Lowside Depth	Restraint Length	Restraint Length 2
Horizontal Bend	Ductile Iron	GW	1.5	3	4 Ft.	150 PSI	12 In.	45°					10 Ft.	

**Site Name:** 45-degree horizontal bend  
**Site Notes:** Minimum restrained length of pipe

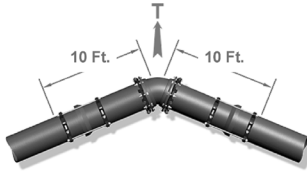

ALL JOINTS WITHIN THE CALCULATED LENGTH MUST BE RESTRAINED  
 IF YOUR DISTANCE BETWEEN FITTINGS IS LESS THAN OR EQUAL TO THE CALCULATED RESTRAINT LENGTH, RESTRAIN ALL JOINTS BETWEEN THOSE FITTINGS.

Fitting Type	Pipe Material	Soil Type	Safety Factor	Trench Type	Depth of Bury	Test Pressure	Nominal Size	Bend Angle	Branch Size	Length Along Run	Reduced Size	Lowside Depth	Restraint Length	Restraint Length 2
Dead End	Ductile Iron	GW	1.5	3	4 Ft.	150 PSI	8 In.						29 Ft.	

**Site Name:** 8-INCH DEAD END  
**Site Notes:**

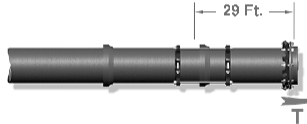

ALL JOINTS WITHIN THE CALCULATED LENGTH MUST BE RESTRAINED  
 IF YOUR DISTANCE BETWEEN FITTINGS IS LESS THAN OR EQUAL TO THE CALCULATED RESTRAINT LENGTH, RESTRAIN ALL JOINTS BETWEEN THOSE FITTINGS.

Fitting Type	Pipe Material	Soil Type	Safety Factor	Trench Type	Depth of Bury	Test Pressure	Nominal Size	Bend Angle	Branch Size	Length Along Run	Reduced Size	Lowside Depth	Restraint Length	Restraint Length 2
Tee	Ductile Iron	GW	1.5	3	4 Ft.	150 PSI	6 In.		6 In.	5 Ft.			10 Ft.	

**Site Name:** 6-inch x 6-inch tee  
**Site Notes:** Minimum restrained length of pipe along branch.  
 Minimum 5-foot length of run on each side of the tee.

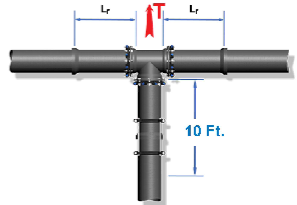

ALL JOINTS WITHIN THE CALCULATED LENGTH MUST BE RESTRAINED  
 IF YOUR DISTANCE BETWEEN FITTINGS IS LESS THAN OR EQUAL TO THE CALCULATED RESTRAINT LENGTH, RESTRAIN ALL JOINTS BETWEEN THOSE FITTINGS.

Fitting Type	Pipe Material	Soil Type	Safety Factor	Trench Type	Depth of Bury	Test Pressure	Nominal Size	Bend Angle	Branch Size	Length Along Run	Reduced Size	Lowside Depth	Restraint Length	Restraint Length 2
Reducer	Ductile Iron	GW	1.5	3	4 Ft.	150 PSI	8 In.				6 In.		12 Ft.	

**Site Name:** 8-inch x 6-inch reducer  
**Site Notes:** Minimum restrained length of pipe.

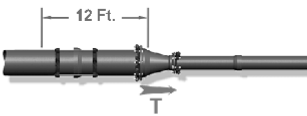

ALL JOINTS WITHIN THE CALCULATED LENGTH MUST BE RESTRAINED  
 IF YOUR DISTANCE BETWEEN FITTINGS IS LESS THAN OR EQUAL TO THE CALCULATED RESTRAINT LENGTH, RESTRAIN ALL JOINTS BETWEEN THOSE FITTINGS.

# TYPICAL JOINT RESTRAINT

MONROE MUNICIPAL UTILITIES AUTHORITY

**BRYSON & YATES**  
**CONSULTING ENGINEERS, LLC**

DATE: 3/24  
 N.T.S.

W-6

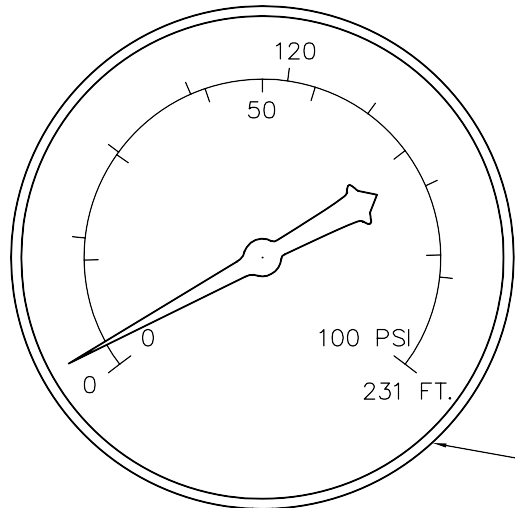

NOTE:  
 ALL FITTINGS ARE TO BE THREADED BRASS. ALL JOINTS ARE TO BE SEALED WITH NON-CEMENTING, NON-TOXIC WATER PROOF SEALER.

6" DIA. LIQUID FILLED DIAPHRAGM PRESSURE GAUGE WITH PSI/FT. HEAD GRADATIONS AND BLEED COCK

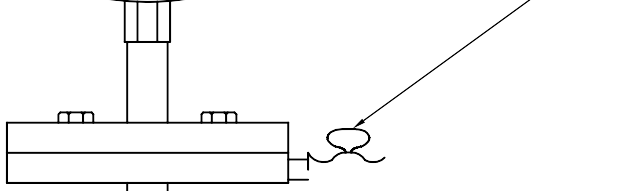

1/2" BALL VALVE (TYP.)

1/2" O.D. BRASS go. ELBOW

1/2" O.D. BRASS NIPPLE (TYP.)

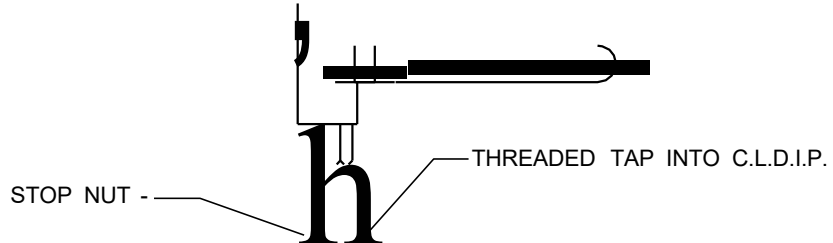
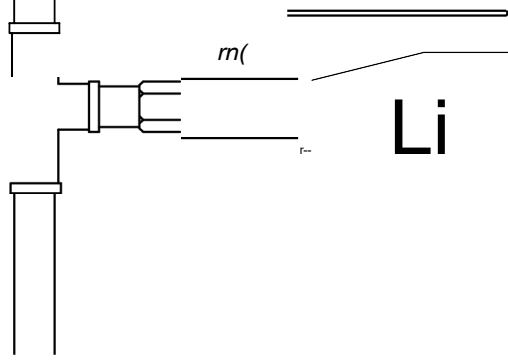

# PRESSURE GAUGE ASSEMBLY DETAIL

MONROE MUNICIPAL UTILITIES AUTHORITY  
 riiJ BRYSON & YATES  
 CONSULTING ENGINEERS, LLC

DATE: 3/24  
 N.T.S. W 7

CAP TO BE COLOR CODED TO DESIGNATE  
 SIZE OF WATER MAIN WITH SHERWIN-WILLIAMS AS FOLLOWS:

- 6" MUELLER YELLOW #F63YL14
- 8" S- W SAFETY GREEN #506
- 10" S-W SAFETY BLUE #505
- >10" S-W SILVER #F63SL5
- BODY OF HYDRANT TO BE SILVER #F63SL5

TRAFFIC BREAK-AWAY COUPLING

SIMILAR TO HYDRANT  
 LOCKING COVER

LOCK TO BE MASTER LOCK  
 KEYED AS SPECIFIED BY  
 AUTHORITY SUPERINTENDENT

GROUND LINE

MAINGUARD 2" POST HYDRANT  
 (SPECIFY DEPTH OF BURY)  
 KUPFERLE FOUNDRY MODEL No. 77

ANY SIZE NOZZLE UP TO 2-1/2" NST

IRON NOZZLE CAP

(SPECIFY OUTLET)

MAINGUARD POST HYDRANT  
 (4' DEEP MINIMUM)

UNDISTURBED EARTH  
 OR THRUST BLOCK

2" BRASS STREET "L"

6 C.U. FT. 3/4"  
 CRUSHED ROCK

# MAINGUARD BLOW-OFF HYDRANT DETAIL

MONROE MUNICIPAL UTILITIES AUTHORITY  
 ffi: J BRYSON & YATES  
 t1l CONSULTING ENGINEERS, LLC  
 DATE: 3/24 W B  
 N.T.S. -

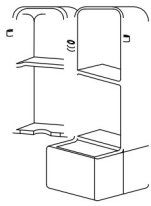

0

**1 3D VIEW**  
Scale: Not To Scale

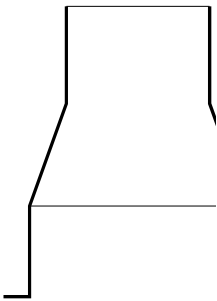
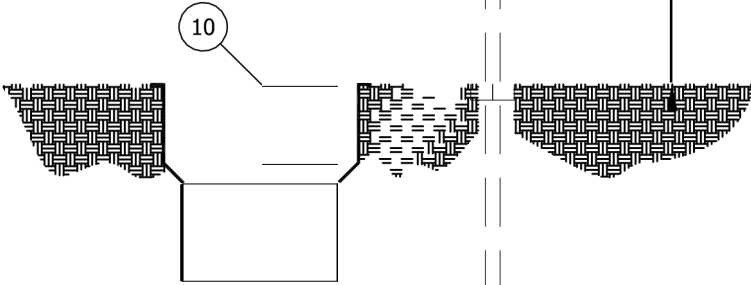

NOTE

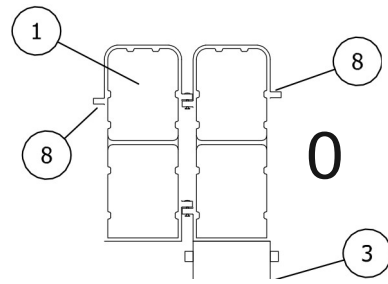
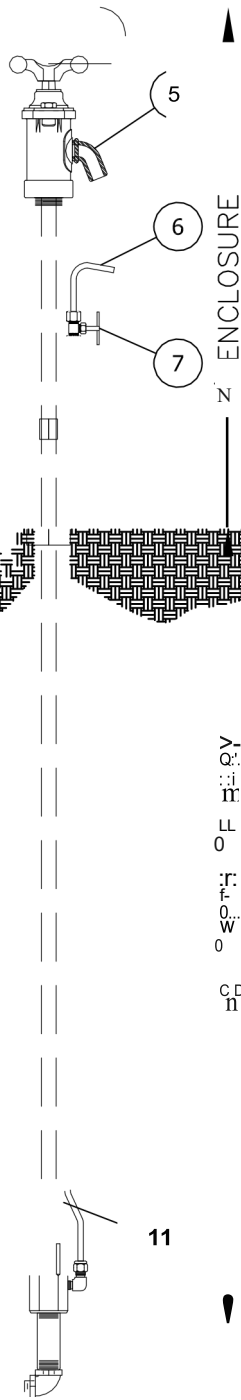

**2 ENCLOSURE OPEN VIEW**  
Scale: Not To Scale

SAMPLING STATION SHALL BE 36" BURY, WITH A 3/4" FIP INLET, AND 1/2" UNTHREADED BLOW OFF AND SAMPLING BIBB.

STATION SHALL BE ENCLOSED IN A LOCKABLE, NON-REMOVABLE ALUMINUM BOX WITH HINGED OPENINGS.

WHEN OPEN, THE STATION SHALL REQUIRE NO KEY FOR OPERATION, AND ALL WATER FLOW SHALL PASS THRU AN ALL STAINLESS STEEL WATERWAY.

ALL WORKING PARTS SHALL BE SERVICABLE FROM ABOVE GROUND WITH NO DIGGING OR REPLACEMENT NEEDED.

A PET COCK WILL BE LOCATED BELOW THE SAMPLING BIBB TO ALLOW PUMPING OF ANY WATER REMAINING INSIDE THE STATION TO INSURE NON-FREEZING.

THE STATION SHALL BE MODEL #88 AS MANUFACTURED BY THE KUPFERLE FOUNDRY, ST. LOUIS MO. 63102 OR APPROVED EQUAL.

ITEM	ITEM / DESCRIPTION	NOTES
1	88 FRONT COVER (COVER A)	
2	88 REAR COVER (COVER B)	
3	88 BASE	2 PIECES
4	3/8" S.S, WATERWAY	
5	BLD OFF 8' SAMPLING BIBB	
6	1/4" COPPER TUBING	
7	PET COCK	
8	LOCKING HOLE	
9	NOT USED	
10	VALVE BOX	BY OTHERS
11	3/4" S,S, NIPPLE	BY OTHERS

NOTES:

- 1.) IN CORROSIVE SOILS THE BURIED PIPE SHOULD BE PREPPED FOR ADDITIONAL RESISTANCE TO CORROSION. KUPFERLE RECOMMENDS SPRAYING ALL UNDERGROUND PIPING AND FITTINGS WITH BITUMINOUS SPRAY TAR, ALLOWING PROPER TIME TO DRY, AND THEN WRAPPING THE PARTS

# SAMPLING STATION DETAIL

MONROE MUNICIPAL UTILITIES AUTHORITY  
111 BRYSON & YATES  
CONSULTING ENGINEERS, LLC

DATE: 3/24 W-g  
N.T.S.

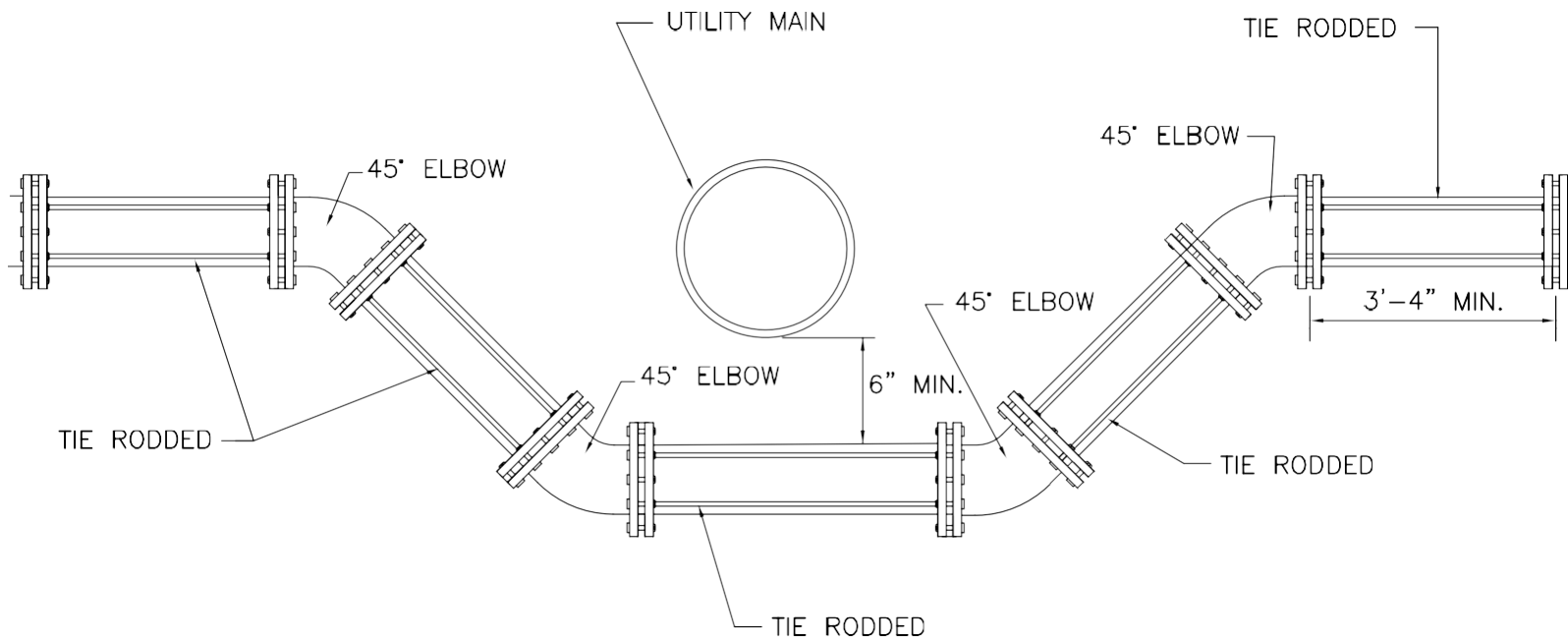

# WATER MAIN OFFSET DETAIL

MONROE MUNICIPAL UTILITIES AUTHORITY

**By** BRYSON & YATES  
CONSULTING ENGINEERS, LLC

DATE: 3/24  
N.T.S.

W-10

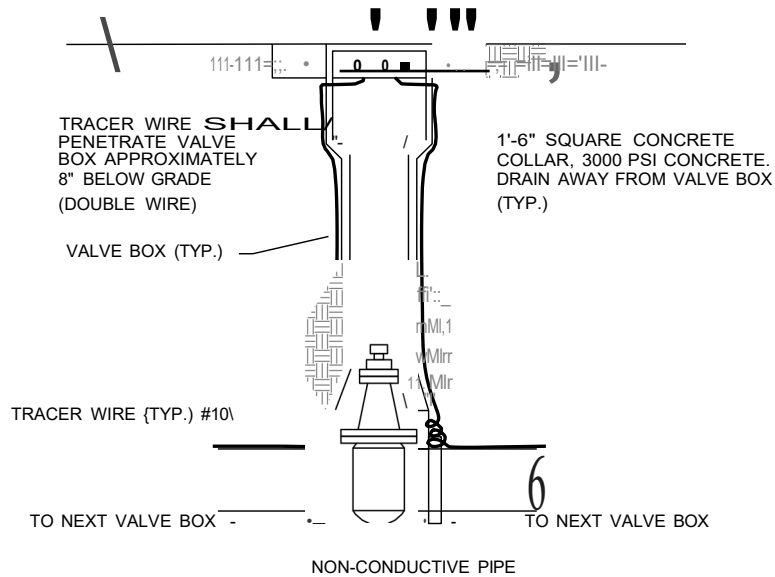

**TYPICAL TRACER WIRE VALVE BOX INSTALLATION**

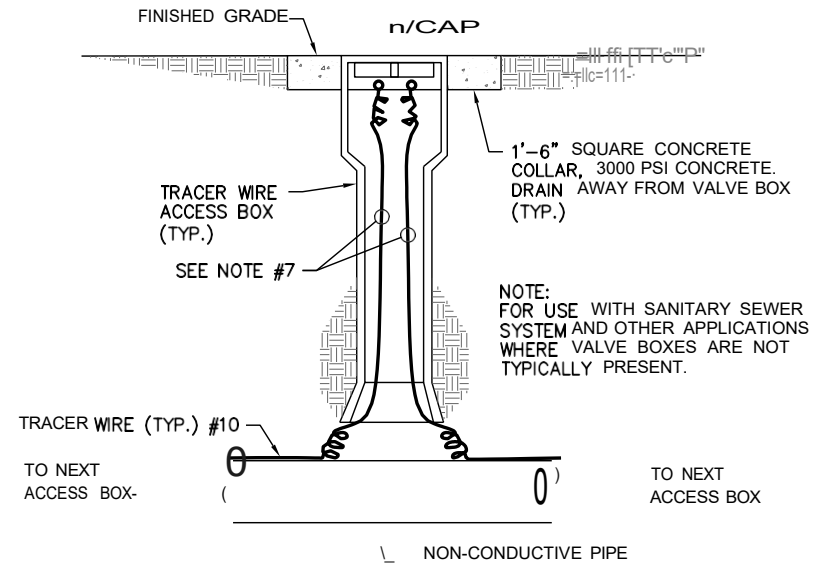

**TYPICAL TRACER WIRE VALVE BOX INSTALLATION  
NON VALVE LOCATIONS**

**NOTES:**

1. TRACER WIRE SHALL BE TIED INTO EVERY VALVE, BLOW-OFF, ARV, AND OTHER DEVICES OR CHANGES IN DIRECTION. PROVIDE ONE TRACER WIRE TEST STATION AT MINIMUM INTERVALS OF 400 FEET.
2. TRACER LEADS SHALL BE INSTALLED IN APPROVED CURB BOXES OR TRACER WIRE ACCESS BOXES. ACCESS BOX STYLE (LIGHT DUTY, DRIVEWAY, OR ROADWAY) SHALL BE DETERMINED BY BOX LOCATION.
3. CURB BOXES SHALL BE INSTALLED FLUSH WITH GROUND AND LOCATED OVER PIPE LINE TO WHICH TRACER LEAD IS ATTACHED.
4. TRACER LEADS SHALL HAVE ADEQUATE SLACK THROUGHOUT THE INSTALLATION TO REDUCE BREAKAGE FROM PULLING.
5. 12" OF SLACK SHALL BE LEFT IN BOX AND WIRES SHALL BE PROPERLY CONNECT TO THE LID TOP PER MANUFACTURERS SPECIFICATIONS. ALL TRACER WIRES SHALL BE OF #10 TW SOLID COPPER WIRE.
6. EARTH AROUND VALVE BOXES SHALL BE THOROUGHLY COMPACTED AT THE TIME OF INSTALLATION. SUBCONTRACTOR SHALL MAKE ADJUSTMENTS FOR FINAL GRADING, SODDING, PAVING AND RESTORATION AT THE COMPLETION OF EACH PROJECT. SUBCONTRACTOR SHALL PROTECT THE LEADS, BOXES AND ALL TRACER WIRES THROUGHOUT THE PROJECT. SUBCONTRACTOR SHALL BE RESPONSIBLE FOR ALL WATER AND WASTERWATER UTILITY LOCATIONS THROUGHOUT THE PROJECT AND UNTIL APPROVED AND ACCEPTED BY THE AUTHORITY.
7. PROVIDE ONE TRACER LEAD IN EACH DIRECTION UNLESS OTHERWISE NOTED.
8. CONTRACTOR SHALL CONFIRM THE REQUIREMENT FOR CONCRETE COLLARS WITH THE AUTHORITY PRIOR TO CONSTRUCTION.

# TRACER WIRE INSTALLATION

MONROE MUNICIPAL UTILITIES AUTHORITY  
 riS:J BRYSON & YATES  
 CONSULTING ENGINEERS, LLC

DATE: 3/24  
 N.T.S.

1B

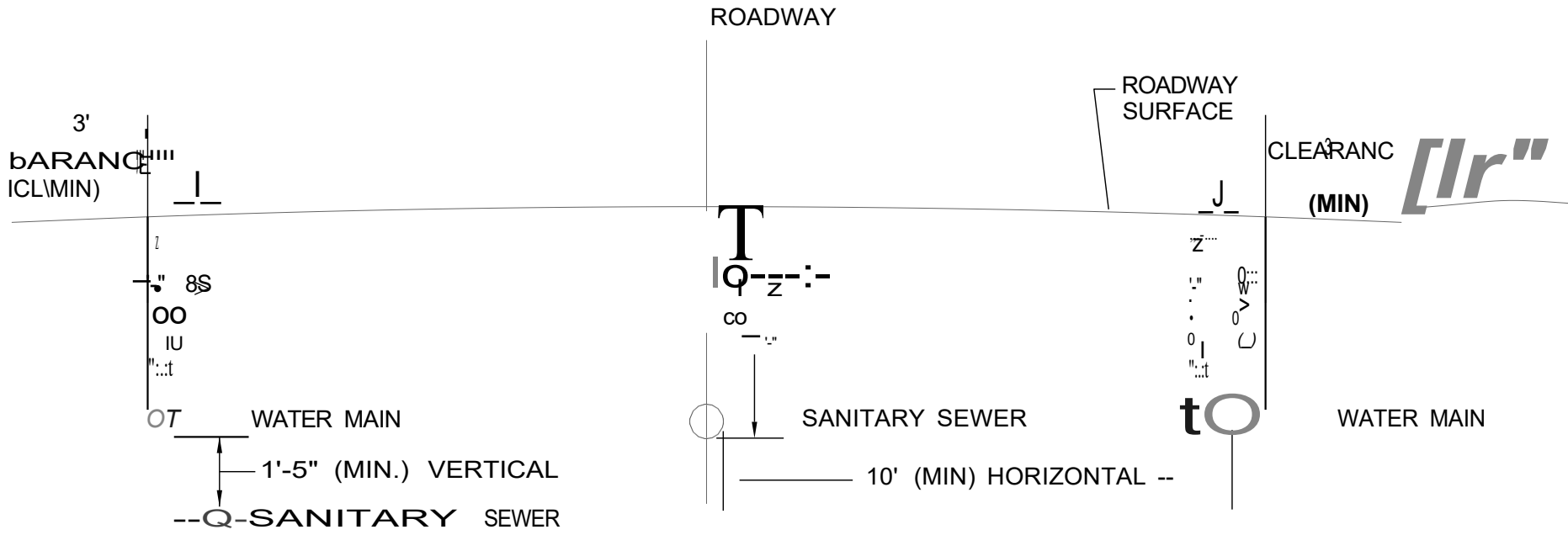

**REDUCED CLEARANCE**

**NORMAL INSTALLATION**

**WATER & SANITARY SEWER MAIN INSTALLATION**

MONROE MUNICIPAL UTILITIES AUTHORITY

TY BRYSON & YATES

TJ CONSULTING ENGINEERS, LLC

DATE: 3/24

MT-

N.T.S.

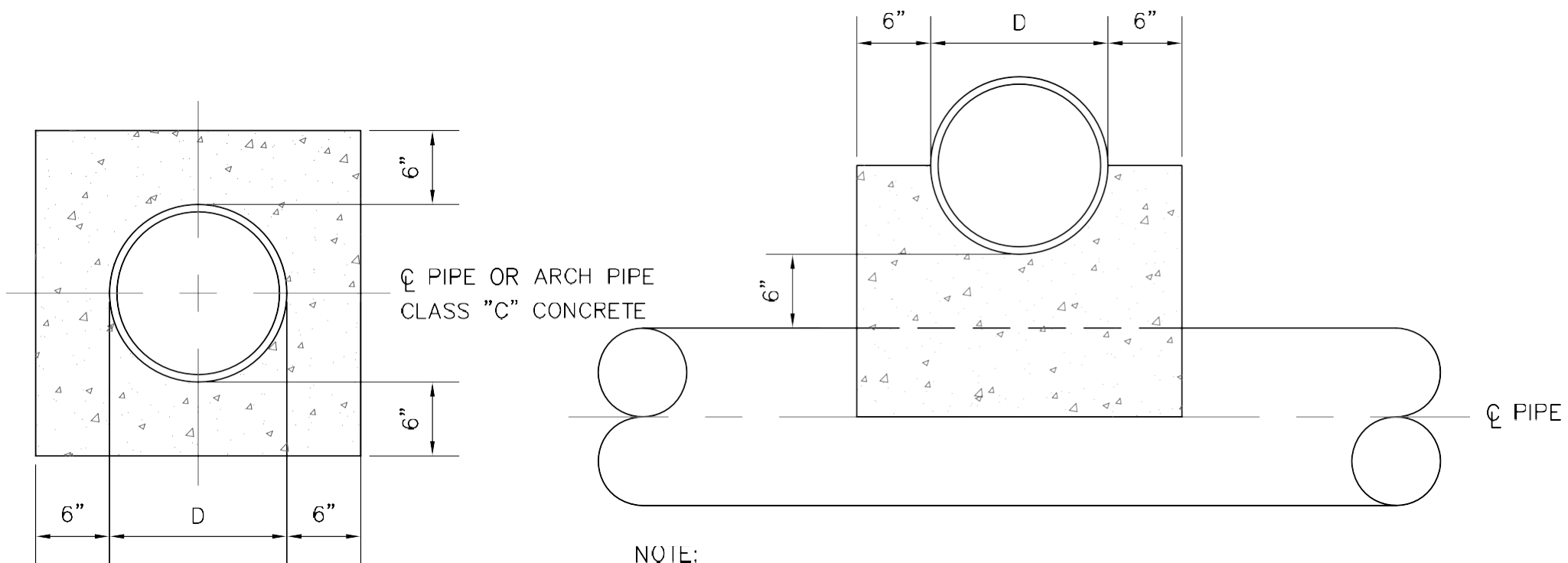

$\varnothing$  PIPE OR ARCH PIPE  
 CLASS "C" CONCRETE

$\varnothing$  PIPE

NOTE:  
 CONSTRIIP BOND BREAKER (WB) OR EQUAL SHALL BE APPLIED  
 TO THE PIPE IN ACCORDANCE WITH THE MANUFACTURES  
 INSTRUCTIONS PRIOR TO POURING CONCRETE.

## CONCRETE ENCASEMENT & SADDLE DETAIL

MONROE MUNICIPAL UTILITIES AUTHORITY

By BRYSON & YATES  
 CONSULTING ENGINEERS, LLC

DATE: 3/24  
 N.T.S.

MT-2

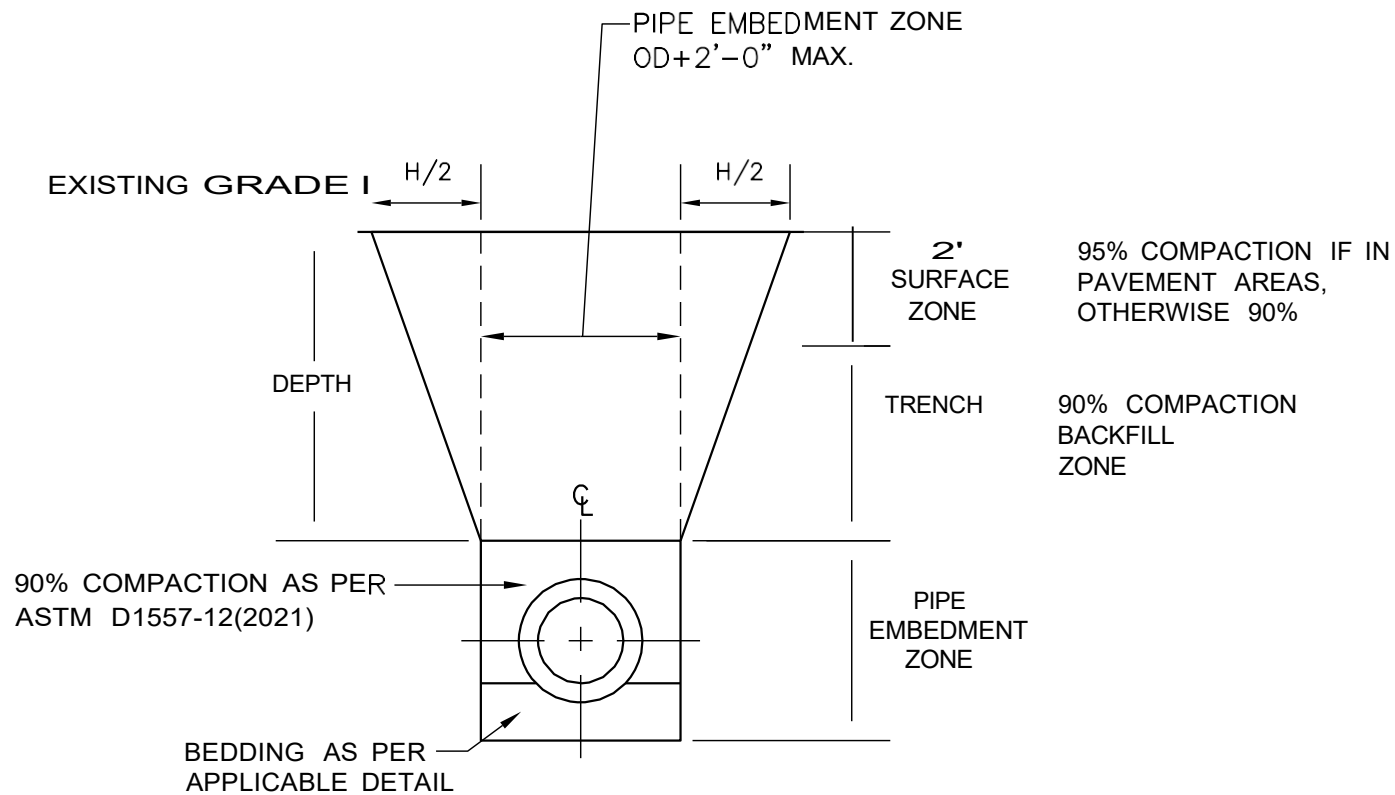

**GENERAL NOTES:**

1. SUITABLE BACKFILL MATERIAL SHALL BE SELECT MATERIAL 1-2 (N.J.D.O.T.) WHEN ON SITE SUITABLE MATERIAL IS NOT AVAILABLE.
2. COMPACTED BACKFILL SHALL BE AS A MINIMUM 90% OF MAXIMUM DRY DENSITY OF SOIL AS DETERMINED BY ASTM D1557-12(2021).
3. COMPACTION OF TOP 2 FEET OF (SURFACE ZONE) UNDER AREAS TO BE PAVED SHALL ACHIEVE AS A MINIMUM 95% OF MAXIMUM DRY DENSITY AS DETERMINED BY ASTM D1557-12(2021).

**TRENCH COMPACTION DETAIL**

MONROE MUNICIPAL UTILITIES AUTHORITY  
 [iii:] BRYSON & YATES  
 CONSULTING ENGINEERS, LLC

DATE: 3/24 MT 3  
 N.T.S. -

NOTE:  
 TRENCH SIDES MAY BE  
 SLOPED AND/OR TRENCH  
 WIDTH MAY BE INCREASED  
 FROM A POINT 1 FT. ABOVE  
 PIPE IN ACCORDANCE WITH  
 SPECIFICATIONS.

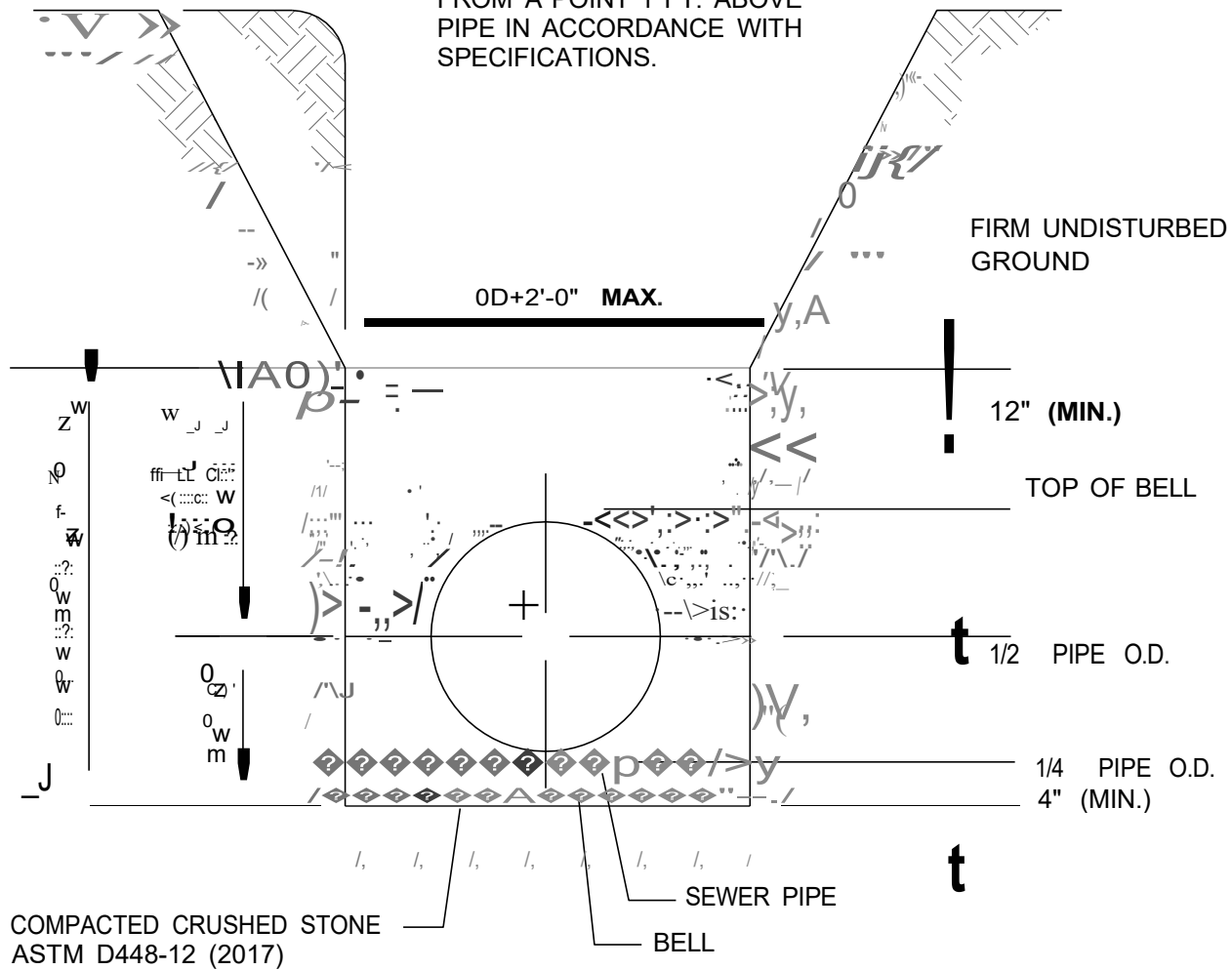

## **CRUSHED STONE CLASS 'B' MODIFIED BEDDING**

MONROE MUNICIPAL UTILITIES AUTHORITY

BRYSON & YALES  
 CONSULTING ENGINEERS, LLC

DATE: 3/24  
 N.T.S.

MT- 4

NOTE:  
 TRENCH SIDES MAY BE  
 SLOPED AND/OR TRENCH  
 WIDTH MAY BE INCREASED  
 FROM A POINT 1 FT. ABOVE  
 PIPE IN ACCORDANCE WITH  
 SPECIFICATIONS.

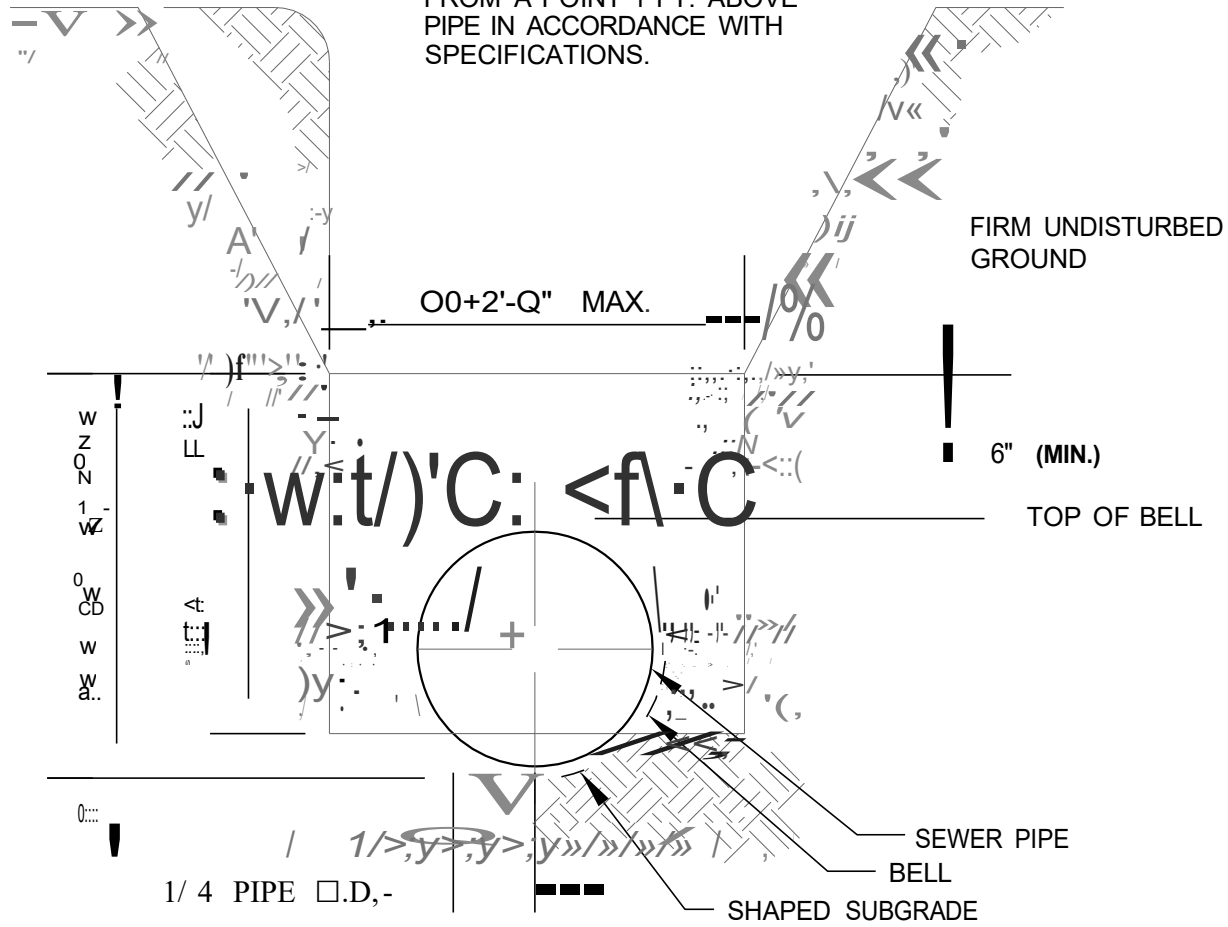

## CLASS 'C' SHAPED BEDDING DETAIL

MONROE MUNICIPAL UTILITIES AUTHORITY

riiJ BRYSON & YATES  
 CONSULTING ENGINEERS, LLC

DATE: 3/24  
 N.T.S.

MT S

-

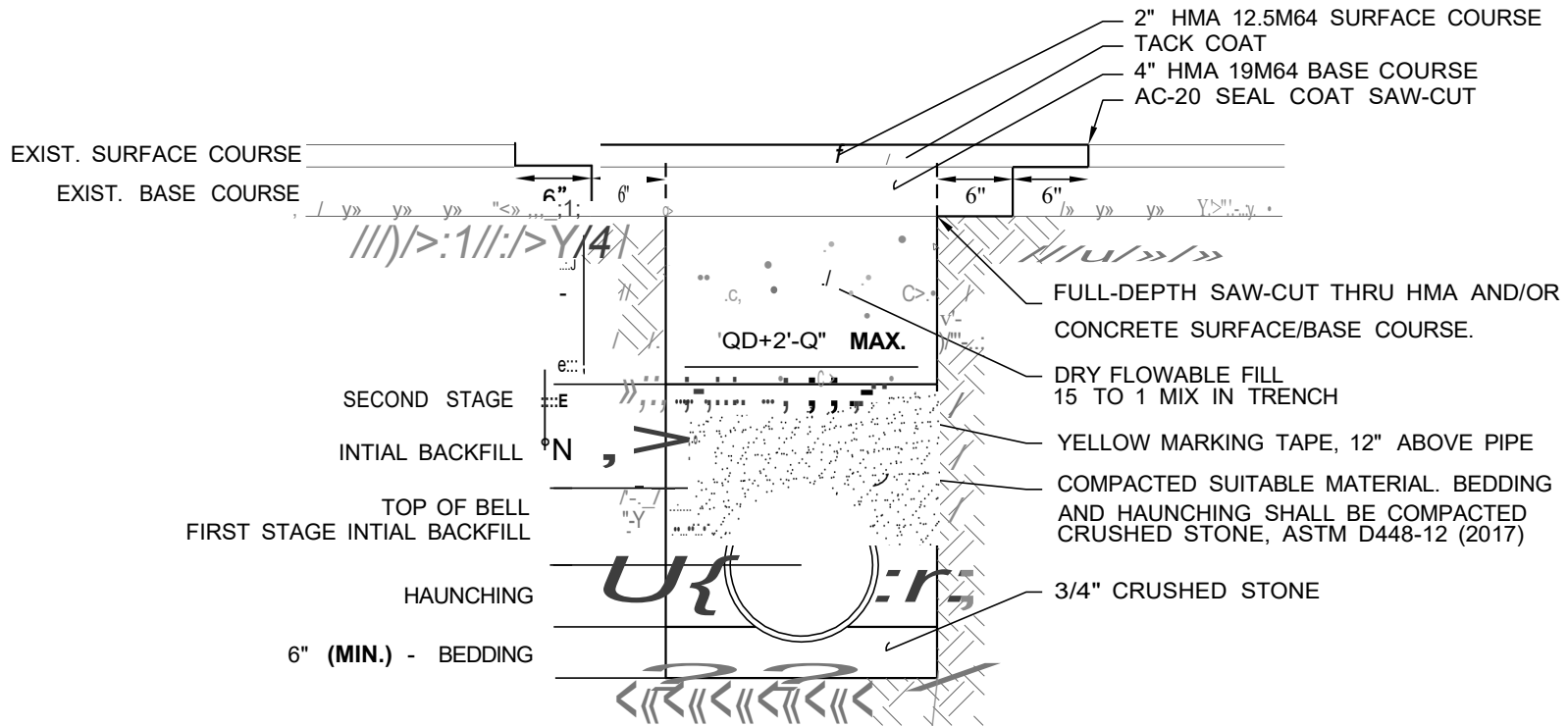

## FLOWABLEFILL TRENCH DETAIL

MONROE MUNICIPAL UTILITIES AUTHORITY  
 BRYSON & YATES  
 CONSULTING ENGINEERS, LLC  
 DATE: 3/24 MT-S  
 N.T.S.

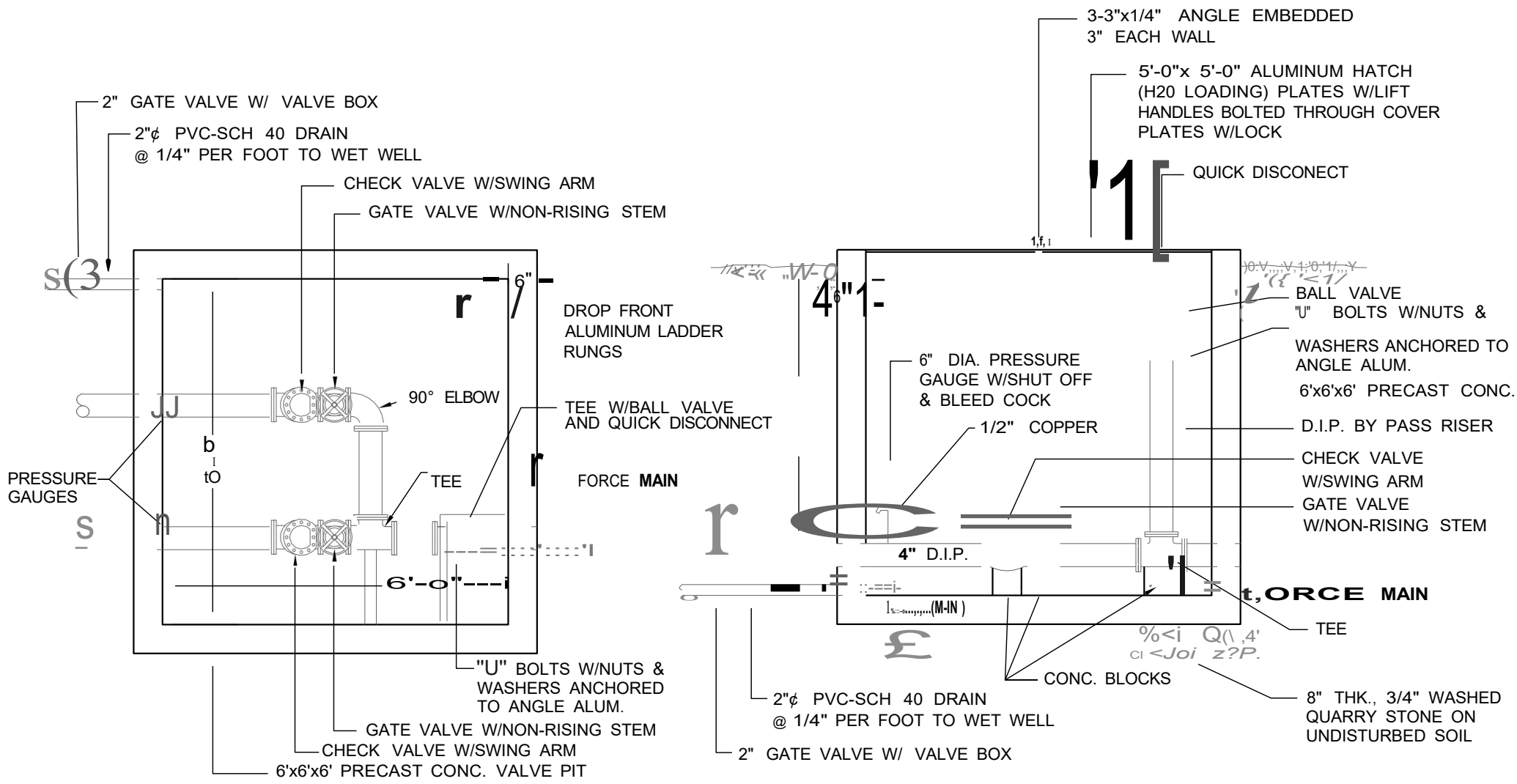

**PLAN VIEW**

**SECTION VIEW**

**PUMP STATION BY-PASS VAULT DETAILS**

MONROE MUNICIPAL UTILITIES AUTHORITY  
 ffi: J BRYSON & YATES  
 I.: .I.I CONSULTING ENGINEERS, LLC  
 DATE: 3/24 PS 1  
 N.T.S.

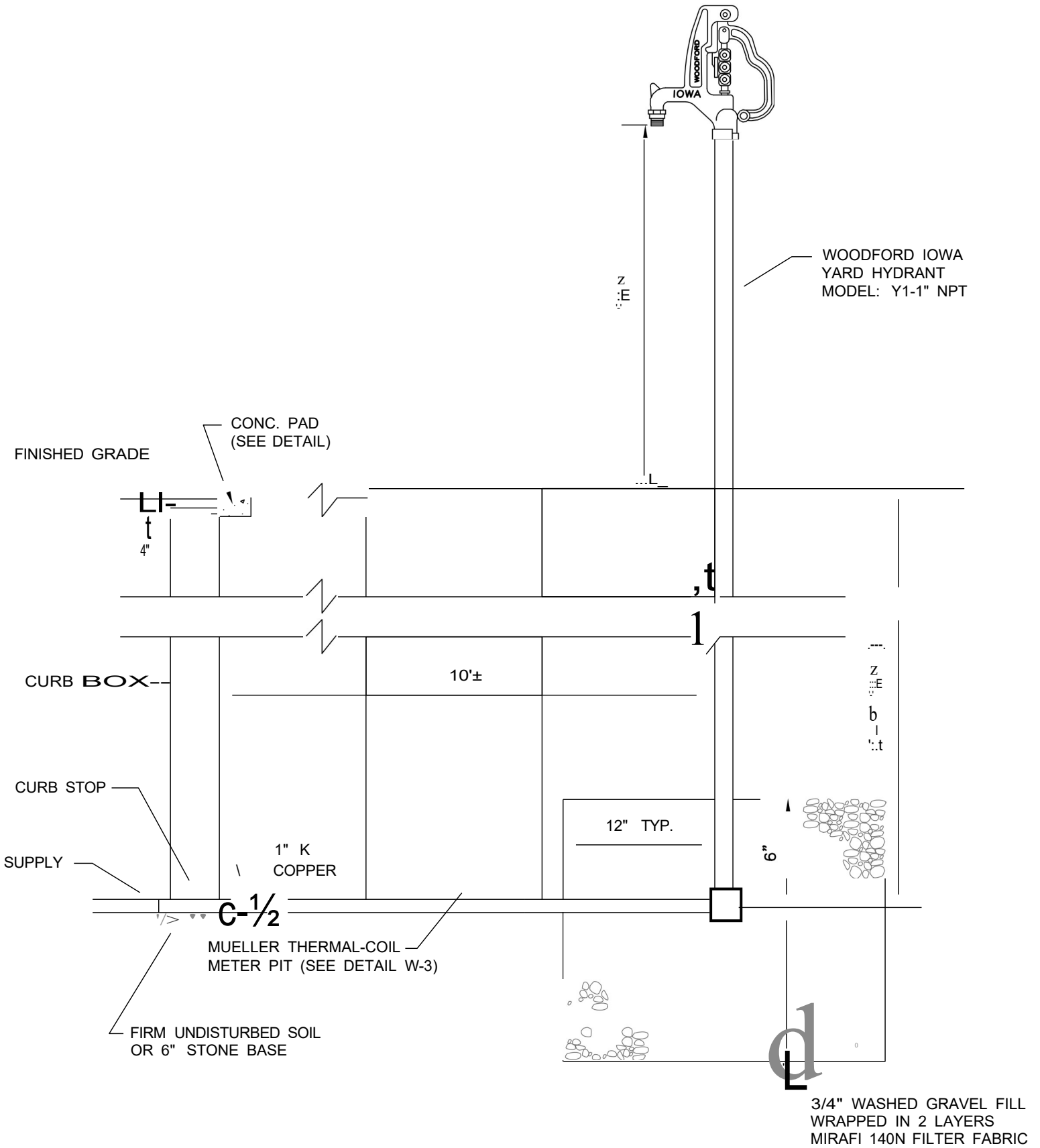

# YARD HYDRANT DETAIL

MONROE MUNICIPAL UTILITIES AUTHORITY  
 11:LI BRYSON & YATES  
 CONSULTING ENGINEERS, LLC  
 DATE: 3/24 PS  
 N.T.S. - 2

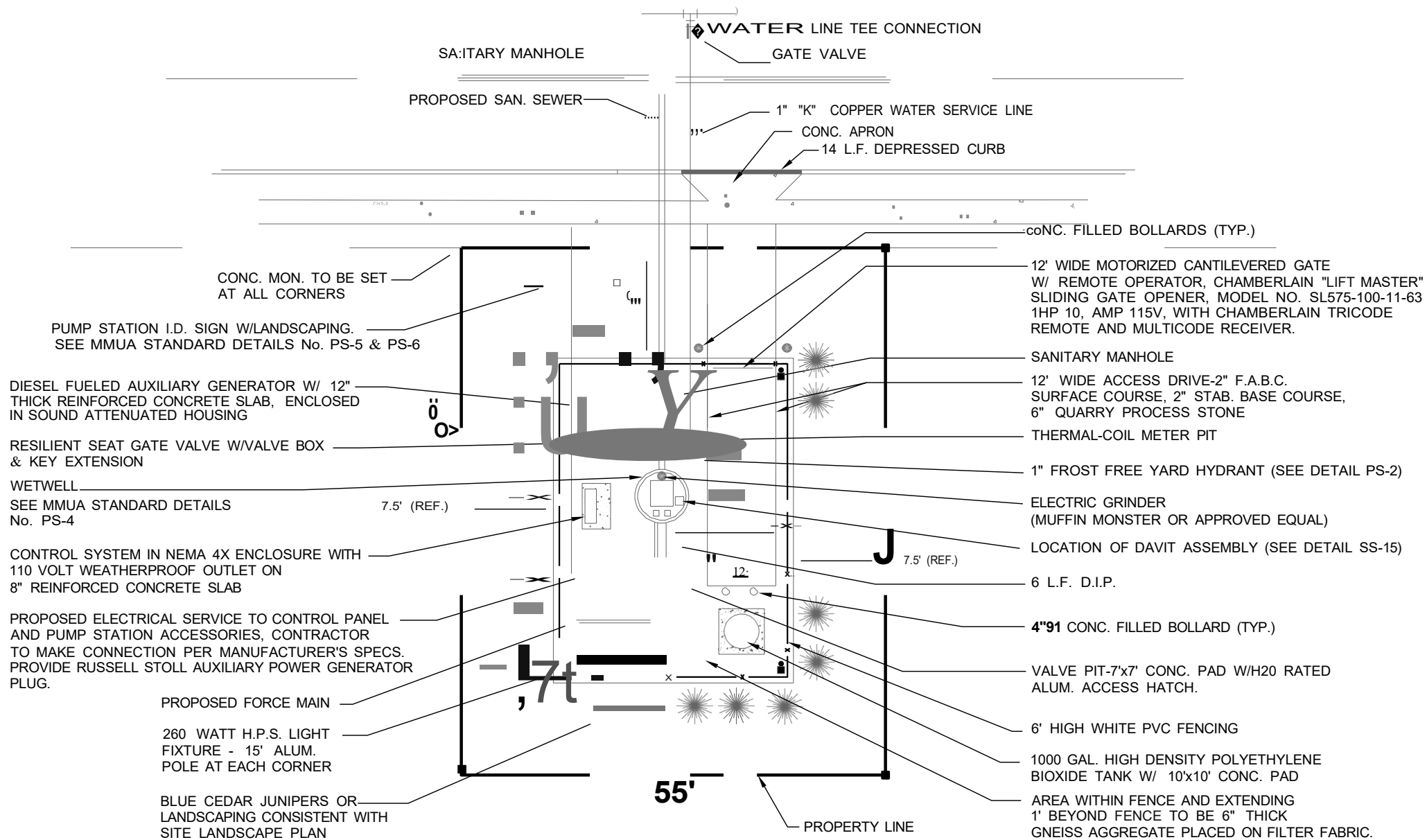

# PUMP STATION SITE PLAN

MONROE MUNICIPAL UTILITIES AUTHORITY  
 115 J BRYSON & YATES  
 CONSULTING ENGINEERS, LLC

DATE: 3/24

PS-3

N.T.S.

4'x 6' ACCESS HATCH "BILCO TYPE JD-3ALH20" ALUMINUM TYPE "J" CHANNEL FRAME, EQUIPED WITH "FALL PROTECTION GRATING SYSTEM" OR APPROVED EQUAL

6" GALVANIZED SCH. 80 VENT PIPE W/BIRD SCREEN AND WAGER COMPANY 2050 ODOR CONTROL SEWER VALVE WITH 6" FLANGE CONNECTION OR APPROVED EQUAL.

GROUND LEVEL

RECESSED JUNCTION BOX W/ 1-1/2" CONDUIT (TYP.)

2'-0" THICK REINFORCED PRECAST CONC. TOP SLAB CONFORMING ASTM SPECIFICATION C-478-906

ACCESS LADDER W/ 1"ϕ RUNGS, 12" ON CENTER-TO-CENTER, SECURED W/ STAINLESS STEEL HARDWARE EVERY 4'

2' x 2' x 3'-6" CONCRETE FOOTING FOR BUMPER POSTS

6"ϕ D.I.P. CL 52 PUMP DISCHARGE

3/8"ϕ - 316 STAINLESS STEEL BAR SCREEN LIFTING CABLE

DRESSER COUPLING MODEL No. 40

\*\* MUFFIN MONSTER MODEL 30005 WITH STAINLESS STEEL WALL MOUNT FRAME AND GUIDE RAIL SYSTEM.

2-1/2"ϕ SCH 40 PVC DRAIN

FROM VALVE CHAMBER (EXTEND 3" BELOW **MINIMUM** LIQUID LEVEL)

Z-LOK CONNECTION (TYP.)

12" DIA. C.L.D.I.P. SAN. SEWER INFLUENT PIPE

4" PVC (SDR-26) STILL WELL FOR MDI TRANSDUCER

(2) 2" GUIDE BAR SCH. 40 PIPE

Z-LOK CONNECTION (TYP.)

RUBBER GASKET AND CEMENT GROUT AT EACH JOINT IN CONFORMANCE WITH ASTM C443-21

(6) 24"x1" SLOTS OPPOSITE SIDES (TYP.)

1'-0"

4" (**MIN.**) PROJECTION OF INFLUENT PIPE

TWO SEPARATE COATS OF APPROVED BITUMASTIC WATERPROOFING COMPOUND APPLIED TO ENTIRE EXTERIOR OF STRUCTURE IN ACCORDANCE WITH THE MANUFACTURER'S INSTRUCTIONS

(2) "FLYGT" MODEL NO. NP-3127 HT3 HT 10 HP SUBMERSIBLE PUMP OR APPROVED EQUAL W/ 215mm IMPELLER & VFD

STAINLESS STEEL STILL WELL SUPPORT W/5"DIA. RINGS (TYP.)

12" (TYP.)

AUTOMATIC DISCHARGE CONNECTION SUPPLIED BY PUMP MANUFACTURER AND PERMANENTLY MOUNTED PER MANUFACTURER'S SPECIFICATIONS HEAVY-DUTY ADJUSTABLE 3/4" ANCHOR BOLTS

6" **MIN.** PER MANUFACTURER'S RECOMMENDATION

CONC. GROUT FILLET, SLOPE 1:1, CLASS 'C' CONCRETE

14'-0" x 14'-0" x 18" THICK REINF CONC. BOTTOM SLAB; NO. 4 REBAR @ 6" O.C. B/W, T/B; 3" CLEAR

FOR PUMP DISCHARGE CONNECTION "FLYGT" CORP. KIT No. 14-58-95-25 (PART #14488200) OR APPROVED EQUAL

12'-0" 1.D. PRECAST REINF. CONC. WET WELL IN ACCORDANCE WITH SPECIFICATION C478-18 W/INTERIOR DURO PLATE 100 PLASTIC LINER AS MFD. BY ATLANTIC CONC. OR APPROVED EQUAL TO BE FACTORY INSTALLED

12" THICK **MIN.** COARSE AGGREGATE BASE N.J.D.O.T. SIZE 57 ON UNDISTURBED SUB-BASE

NOTE: PUMP STATION TO BE EQUIPPED WITH "ITT FLYGT GRIP EYE SYSTEM" OR APPROVED EQUAL AND "ITT FLYGT MIX FLUSH SYSTEM" OR APPROVED EQUAL.

\*NOTE: **MINIMUM** INTERIOR DIAMETER OF THE WET WELL IS EIGHT (8) FEET.

\*\*NOTE: THE DESIGN ENGINEER SHALL CONFIRM THE SPECIFIC MODEL NUMBER BASED ON PEAK INFLUENT FLOW RATE.

# STANDARD WETWELL DETAIL

MONROE MUNICIPAL UTILITIES AUTHORITY  
 ILLI BRYSON & YATES  
 CONSULTING ENGINEERS, LLC

DATE: 3/24  
 N.T.S.

PS-4

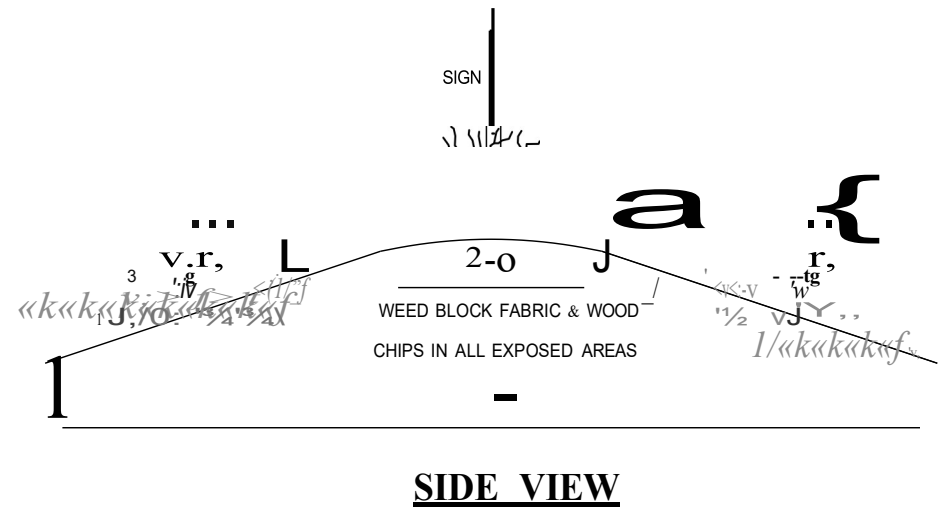
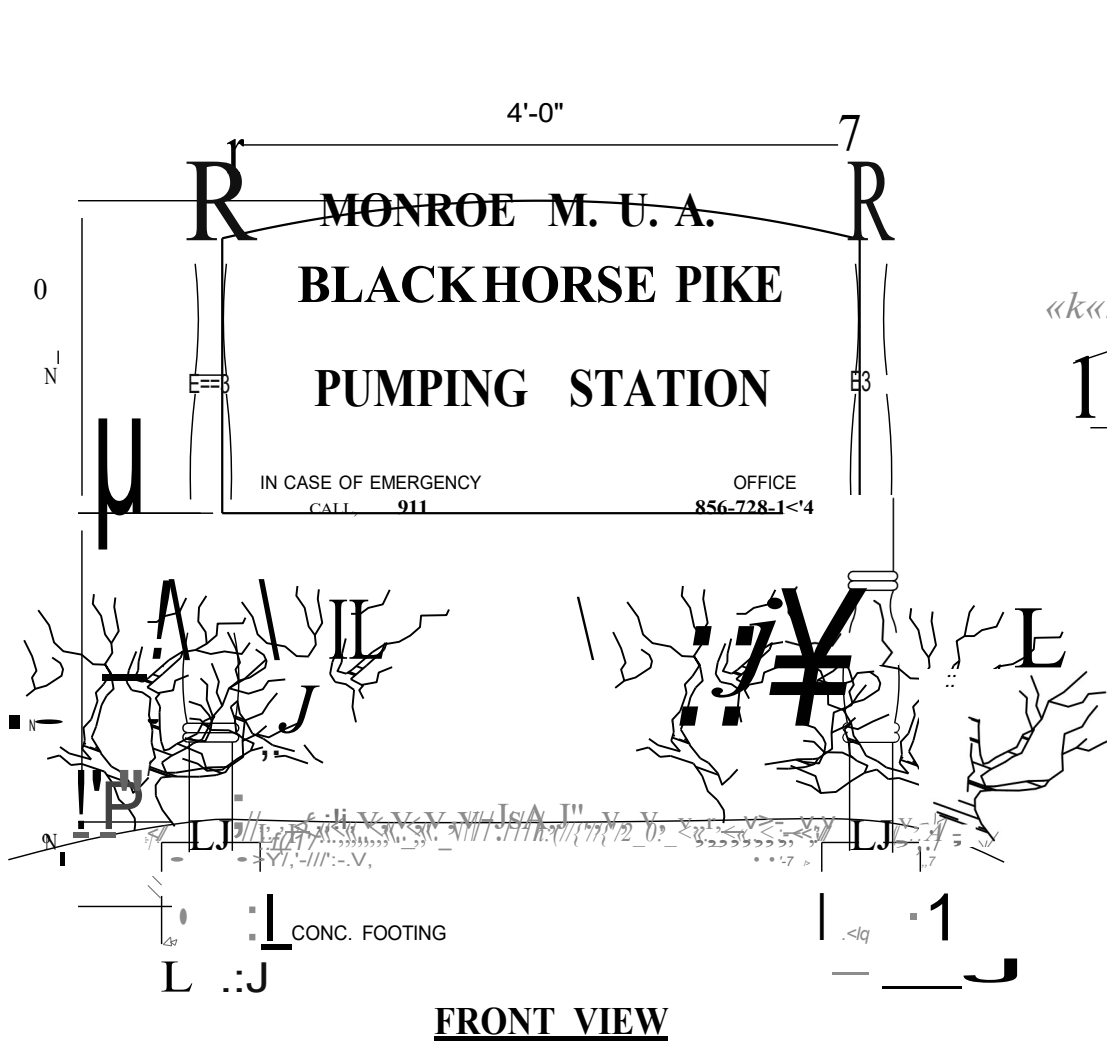

NOTE:  
SIGN IS TO BE SAND BLASTED WOOD.  
SIGN DESIGNS ARE TO BE  
SUBMITTED TO AUTHORITY ENGINEER  
FOR REVIEW AND APPROVAL PRIOR  
TO CONSTRUCTION

## SIGN DETAIL

MONROE MUNICIPAL UTILITIES AUTHORITY  
BRYSON & YATES  
CONSULTING ENGINEERS, LLC

DATE: 3/24  
N.T.S.

PS S  
-

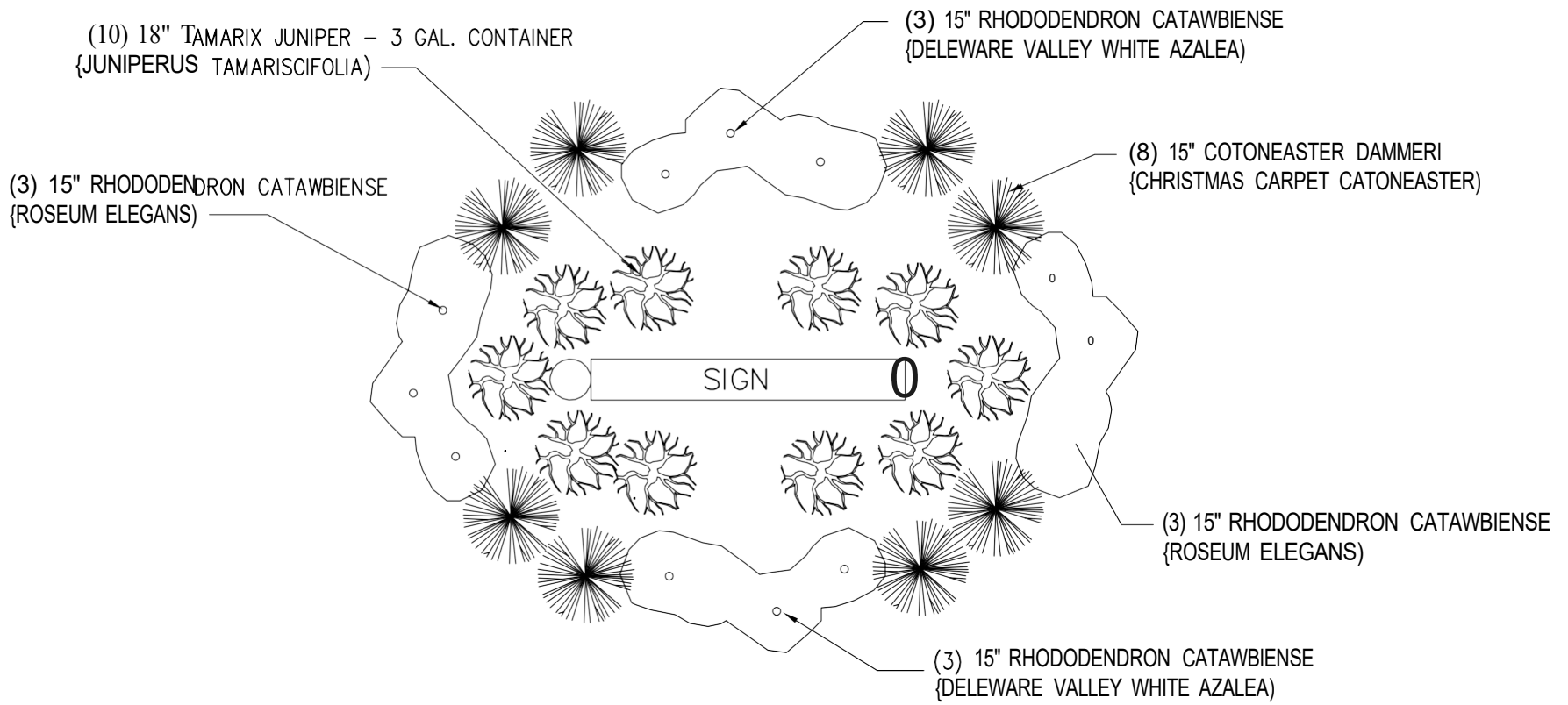

# SIGN - PLAN DETAIL

MONROE MUNICIPAL UTILITIES AUTHORITY  
 ro: J BRYSON & YATES  
 CONSULTING ENGINEERS, LLC

DATE: 3/24  
 N.T.S.

PS S  
 -

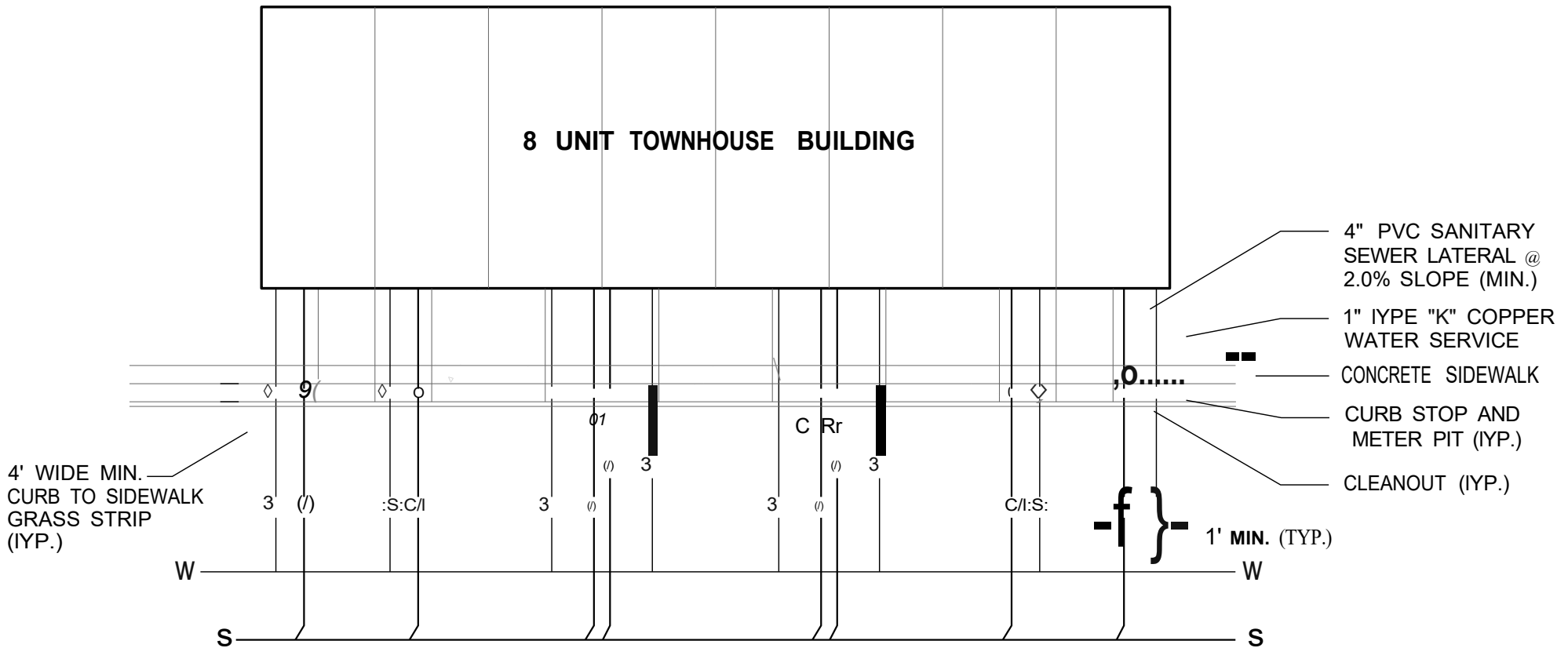

**NOTES:**

1. WATER SERVICES AND SANITARY SEWER LATERALS SHALL NOT BE CONSTRUCTED UNDER DRIVEWAYS OR DRIVEWAY APRONS.
2. WATER SERVICE CURB BOXES AND METER PITS SHALL BE LOCATED IN THE GRASS AREA BETWEEN THE CURB AND SIDEWALK.
3. THE SANITARY SEWER CLEANOUTS SHALL ALSO BE LOCATED IN THE GRASS AREA BETWEEN THE CURB AND SIDEWALK.

## TOWNHOUSE UTILITY PLAN

MONROE MUNICIPAL UTILITIES AUTHORITY  
 BRYSON & YATES  
 CONSULTING ENGINEERS, LLC

DATE: 3/24  
 N.T.S.

MO 1

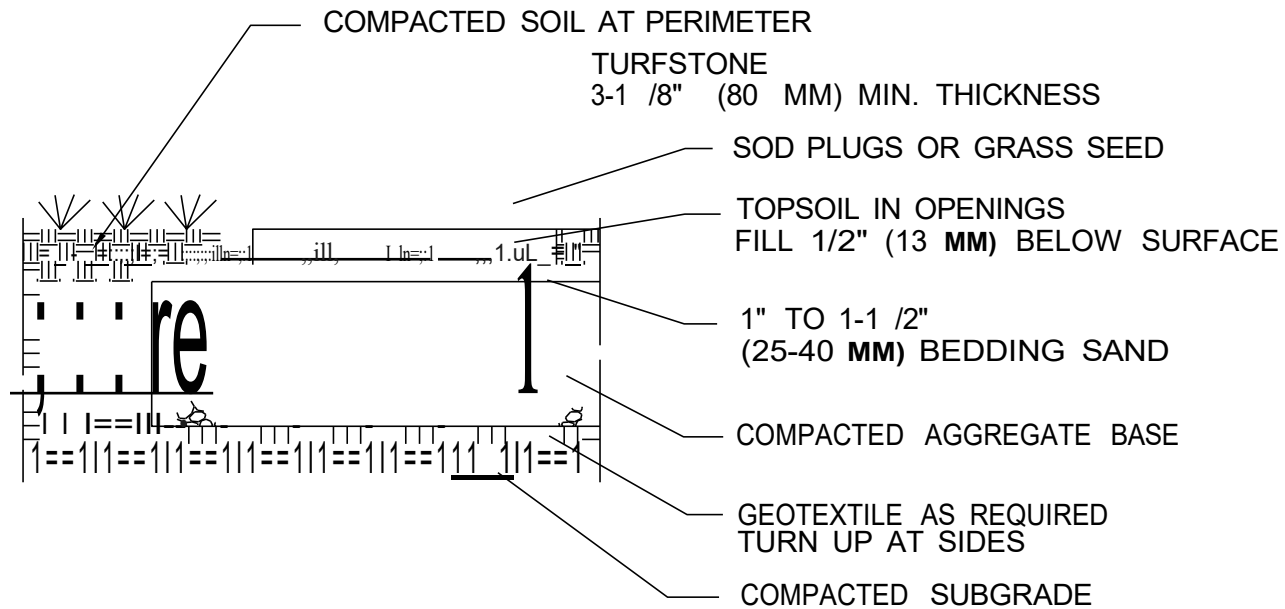

NOTES:

1. BASE THICKNESS VARIES WITH TRAFFIC, CLIMATE, AND SUBGRADE.
2. MINIMUM BASE THICKNESS: 6" (150 MM) RESIDENTIAL DRIVEWAYS  
8" FIRELANES & PARKING LOTS

## GRASS PAVER BLOCK DETAIL

MONROE MUNICIPAL UTILITIES AUTHORITY  
 11u BRYSON & YATES  
 CONSULTING ENGINEERS, LLC  
 DATE: 3/24  
 N.T.S.

MO- 2

## TYPICAL 8 UNIT BUILDING

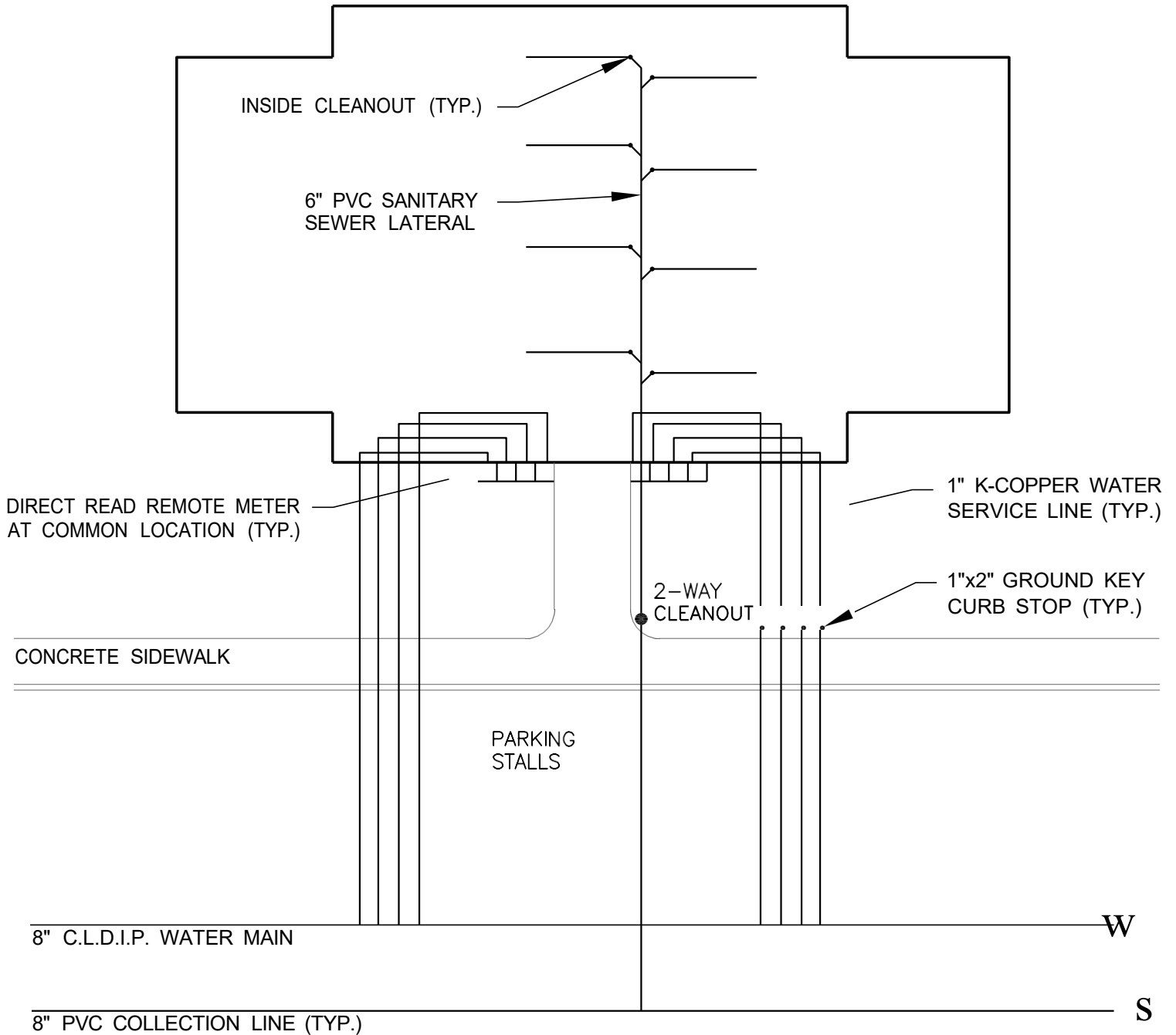

**NOTES:**

1. SEPERATE SHUTOFFS AND METERS SHALL BE PROVIDED FOR EACH CONDOMINIUM UNIT.
2. THE AUTHORITY ENGINEER SHALL BE NOTIFIED IF THE TYPICAL SEWER AND WATER CONNECTIONS AS SHOWN ARE NOT ADHERED TO.

# TYPICAL CONDOMINIUM UTILITY PLAN

MONROE MUNICIPAL UTILITIES AUTHORITY

BRYSON & YATES  
CONSULTING ENGINEERS, LLC

DATE: 3/24

N.T.S.

**MO-3**

## MO-4 GENERAL SANITARY SEWER AND WATER MAIN NOTES

1. THE CONTRACTOR SHALL OBTAIN ALL APPLICABLE PERMITS AT NO COST TO THE AUTHORITY INCLUDING BUT NOT LIMITED TO A ROAD OPENING PERMIT FROM THE TOWNSHIP/BOROUGH AND COUNTY, AND STATE.
2. COVER ALL WATER MAINS SHALL BE 4'-0" MINIMUM.
3. THE CONTRACTOR SHALL NOTIFY THE APPROPRIATE UTILITY COMPANY IN ADVANCE OF CONSTRUCTION FOR TEMPORARY SUPPORT OF UTILITY POLES.
4. THE CONTRACTOR SHALL COMPLY WITH ALL STANDARDS SET FORTH IN THE MMUA RULES AND REGULATIONS AND THE "INSPECTION AND TESTING PROCEDURES MANUAL" INCLUDED IN THE SPECIFICATIONS.
5. LOCATION AND/OR DEPTHS OF EXISTING UTILITIES MUST BE VERIFIED IN THE FIELD BY THE CONTRACTOR PRIOR TO START OF CONSTRUCTION.
6. ALL TRENCHES WILL BE BACKFILLED BY COMPACTION IN **SIX (6) INCH** LAYERS IN STRICT ACCORDANCE WITH THE TRENCH DETAILS AND THE SPECIFICATIONS.
7. NO MATERIAL SHALL BE PLACED OR DISTURBED BEYOND THE PROPERTY LINES OR RIGHT-OF-WAY LINES WITHOUT WRITTEN PERMISSION OF THE PROPERTY OWNER DIRECTLY INVOLVED.
8. INSPECTION OF, OR FAILURE TO, INSPECT ANY MATERIALS OR WORKMANSHIP BY THE ENGINEER FOR THE MMUA SHALL IN NO WAY RELIEVES THE CONTRACTOR OF THE RESPONSIBILITY TO PERFORM THE WORK IN ACCORDANCE WITH THE APPROVED PLANS, SPECIFICATIONS AND APPLICABLE LAWS.
9. WHENEVER THE TRENCH BOTTOM DOES NOT AFFORD SUFFICIENT BEARING STRENGTH TO SUSTAIN THE WEIGHT OF THE PIPE AND SUPERIMPOSED LOADS, THE TRENCH BOTTOM SHALL BE OVER EXCAVATED AND STABILIZED WITH **SIX (6) INCH MINIMUM** THICK LAYERS OF CRUSHED STONE, AS DIRECTED BY THE ENGINEER.
10. THE CONTRACTOR SHALL BE RESPONSIBLE FOR RESTORING, PAVING, AND TOP SOILING, FERTILIZING AND SEEDING OF ALL AREAS DISTURBED BY HIS ACTIVITIES. ROAD PAVEMENT REPLACEMENT AND ALL RESTORATION IN ROADS SHALL MEET THE REQUIREMENTS OF THE ENGINEER.

11. ALL TESTING OF NEW WATER MAINS AND OTHER APPURTENANCES SHALL BE COMPLETED AND EXECUTED DISINFECTION CERTIFICATE AS INCLUDED IN THE "INSPECTION AND TESTING PROCEDURES MANUAL," INCLUDED IN THE M.M.U.A. RULES AND REGULATIONS.
12. THE CONTRACTOR SHALL COORDINATE THE LOCATION OF EACH WATER SERVICE LINE WITH THE PROPERTY OWNER DIRECTLY INVOLVED.
13. ALL GENERAL CONSTRUCTION, MATERIALS, TESTING, AND METHODS OF INSTALLATION SHALL BE SUBJECT TO THE APPROVAL OF THE MMUA ENGINEER.
14. ALL GRASS AREAS DISTURBED WITHIN STATE RIGHT-OF-WAY SHALL BE RESTORED UTILIZING THE RESTORATION SPECIFICATIONS MADE PART OF THE N.J.D.O.T. PERMIT.
15. ALL SANITARY SEWER MAIN UP TO A MAXIMUM DEPTH OF TEN FEET (10') SHALL BE POLYVINYL CHLORIDE PIPE (P.V.C.) MEETING ASTM D3034-21 SDR 35 SPECIFICATION WITH 8" X 4" TEE WYES AT ALL LATERAL INTERCONNECTIONS. PIPE OVER TEN FEET (10') DEEP UP TO TWENTY FEET (20') DEEP SHALL BE PVC SDR 26. LOCATIONS AND SLOPES OF THE MAINS AND ALL APPURTENANCES SHALL BE CONSTRUCTED IN ACCORDANCE WITH THE APPROVED PLANS.
16. ALL SANITARY SEWER LATERALS SHALL BE POLYVINYL CHLORIDE PIPE (P.V.C.) MEETING ASTM D3034-21 SDR 26 SPECIFICATIONS. LOCATIONS AND SLOPES OF THE LATERALS AND ALL APPURTENANCES SHALL BE CONSTRUCTED IN ACCORDANCE WITH THE APPROVED PLANS.
17. ALL FOUR (4) INCH AND LARGER WATER PIPE SHALL BE CLASS 52 CEMENT LINED DUCTILE IRON PIPE (C.L.D.I.P.) WITH PUSH-ON JOINTS. WATER PIPE SMALLER THAN THREE (3) INCHES SHALL BE TYPE "K" SOFT TEMPER COPPER TUBING WITH COMPRESSION FITTINGS. ALL WATER PIPE SHALL HAVE **FORTY-EIGHT (48) INCH MINIMUM OF COVER**.
18. WATER PIPE SHALL BE DISINFECTED BY THE CONTRACTOR, BY CONTACT WITH A CHLORIDE SOLUTION NO LESS THAN FIFTY (50) PPM FOR NOT LESS THAN TWENTY-FOUR (24) HOURS, AND CERTIFIED IN WRITING BY THE CONTRACTOR OF ITS COMPLETION.
19. WATER MAINS AND SANITARY SEWER MAINS SHALL BE SEPARATED BY AT LEAST **TEN (10) FEET** HORIZONTALLY WHEREVER POSSIBLE. OTHERWISE, THE SANITARY SEWER AND WATER SHALL BE IN SEPARATE TRENCHES WITH THE SANITARY SEWER **18 INCHES MINIMUM** BELOW THE WATER MAIN. THE SANITARY SEWER SHALL BE 18 INCHES BELOW THE WATER MAIN AND/OR STORM PIPE AT ALL CROSSINGS. WHERE THE SANITARY SEWER

CROSSES OVER OR WITHIN 18 INCHES UNDER A WATER MAIN AND/OR STORM PIPE, THE SANITARY SEWER SHALL BE DUCTILE IRON PIPE WITH SLIP-ON JOINTS FOR AT LEAST TEN (10) FEET ON EACH SIDE OF THE CROSSING.

20. ALL WATER MAIN AND SANITARY SEWER CONSTRUCTION, MATERIALS, AND TESTING SHALL BE SUBJECT TO THE APPROVAL OF THE MONROE MUNICIPAL UTILITIES AUTHORITY, THE GLOUCESTER COUNTY UTILITIES AUTHORITY, AND THE NEW JERSEY DEPARTMENT OF ENVIRONMENTAL PROTECTION.
21. SANITARY SEWER LATERALS SHALL CONFORM TO STANDARD INSTALLATION REQUIREMENTS AND MAY NOT BE CONNECTED DIRECTLY INTO MANHOLES.
22. THE CONTRACTOR SHALL SUPPLY THE MMUA WITH COMPLETE AS-BUILTS OF ALL UTILITY INSTALLATIONS AND APPURTENANCES BEFORE THE MMUA WITNESSES THE TESTING OF THE SYSTEMS.
23. ALL PVC FORCE MAINS SHALL BE INSTALLED WITH TRACING WIRE.
24. SANITARY SEWER MANHOLES SET IN LOCATIONS SUBJECT TO SHEET FLOWS OF WATER (I.E. GUTTER LINE OF ROAD) SHALL HAVE WATERTIGHT FRAME AND LID; BRIDGESTATE PATTERN #1541.
25. SANITARY SEWER MANHOLES SET IN LOCATIONS OTHER THAN PAVED ROADWAYS (I.E. GRASSY EASEMENTS) SHALL HAVE LOCKING LIDS; BRIDGESTATE PATTERN #1460A.
26. ALL SERVICE SADDLES FOR USE ON P.V.C. WATER MAIN SHALL BE ALL STAINLESS STEEL 370 SERIES AS PRODUCED BY SMITH-BLAIR.
27. ANY REFERENCE TO ASTM AND/OR AWWA STANDARDS SHALL BE INTERPRETED AS THE CURRENT VERSIONS OF SUCH STANDARDS.

*INSPECTION AND TESTING PROCEDURES MANUAL*  
*FOR*  
*MONROE MUNICIPAL UTILITIES AUTHORITY*  
*(SUPPLEMENTING THE ADOPTED RULES AND REGULATIONS)*

APPENDIX "A"

March 2005  
Revised March 2024

Prepared by:

BRYSON & YATES, CONSULTING ENGINEERS, LLC  
307 Greentree Road  
Sewell, New Jersey 08080-9217  
(856) 589 - 1400

## SECTION I - TESTING PROCEDURE FOR PUBLIC WATER SUPPLY SYSTEMS

### **1.1 Objective**

This procedure establishes the methods which are to be used for the testing of the public water supply systems.

### **1.2 Purpose**

The purpose of this procedure is to establish a uniform method and practice in testing public water supply systems for exfiltration, chlorine residual, (sterilization), and bacteria.

**1.2.1.** All testing shall be performed in the presence of the Authority's Engineer.

**1.2.2.** Except as specified herein or as directed by the Superintendent, hydrostatic testing of water mains shall be performed in advance of disinfection and bacteria testing in accordance with AWWA C600-17 or AWWA C605-21 as appropriate.

**1.2.3.** Except as specified herein or directed by the Superintendent, disinfecting water mains shall be performed in accordance with AWWA C651-14.

**1.2.4.** The contractor must submit four (4) complete copies of as-builts of all utilities and appurtenances to the Authority prior to the Authority accepting any test results.

**1.2.5.** All pressure gauges shall have a minimum pressure range of zero (0) to 1.75 times the required pressure. Gauges with pressure ranges exceeding 2.75 times the required pressure will not be accepted.

**1.2.6.** All pressure gauges shall be calibrated within one calendar year prior to the date of the test. All calibrations must be traceable to the National Institute of Standards and Technology. The contractor must be able to prove this certification prior to any testing being conducted.

### **1.3 Exfiltration Test Procedure**

**1.3.1.** After the pipe has been laid or installed, it shall be subjected to a pressure and leakage test. For pressure piping trench, this shall be conducted prior to the complete backfilling of the trench, unless otherwise permitted by the Engineer, and for pressure piping in structures, this shall be conducted prior to the completion of any construction which would make it impossible or difficult to gain access to the pipe if found defective. The Contractor shall test sections of the pipes between valves, where practicable or where ordered by the Engineer.

**1.3.2.** The Contractor shall make the necessary arrangements with the Authority for the procurement of water for the pressure and leakage tests, and for subsequent sterilization, and shall furnish the necessary labor, pumps, valves, pressure gauges, water meters and

all other equipment required for this purpose. Each section of pipe shall be subjected to hydrostatic pressure **150 psi and maintained for a period of one (1) hour.**

Before applying the specified test pressure, all air shall be expelled from the pipe, through hydrants, blow-offs, or any taps that may be necessary for the release of air from the highest points. Taps required for the release of air and blow-offs required for filling the line shall be furnished and installed by the Contractor. The cost of such taps shall be included in the unit prices bid for the water main.

- 1.3.3. The monitoring pressure gauge shall have a pressure range of 0 to 300 PSI minimum. Pressure gauge range shall not exceed 2.75 times the pressure necessary for the required test.
- 1.3.4. In the event that the pressure drops the source must be determined and repaired. After the repair is complete the section of pipe can be re-tested.
- 1.3.5. It is recommended that pressure testing be completed prior to sterilization and bacteria testing.

1.4 **Sterilization**

- 1.4.1. Each completed unit of the water main in distribution system shall be thoroughly sterilized with chlorine before it is placed in operation. The amount of chlorine applied shall be such as to provide a dosage of at least 50 ppm. The contact period shall be at least 24 hours, at the end of which the chlorine residual shall be at least 10 ppm. The line should then be flushed with clean water until **the chlorine residual is not greater than 0.2 ppm.**
- 1.4.2. The chlorine required shall be in the form of high test calcium hypochlorine (HTH) in tablet form. The number of tablets required per length of pipe shall be determined from the following table:

<u>Length of Section</u>	<u>6"</u>	<u>8"</u>	<u>10"</u>	<u>12"</u>
13'	2	3	4	4
18'	3	3	4	4
20'	3	4	5	6

The required number of tablets should fastened to the top of each length of pipe as it is laid using hot tar or "Permatex No. 2" gasket cement as the adhesive. Care should be taken to see that the adhesive only covers the side of each tablet so that as much surface as possible is exposed to the water when it is introduced into the main.

- 1.4.3. Other methods of sterilization may be used, however, prior approval of the engineer in writing must be obtained prior to the test being performed. The Contractor will be required to complete the attached form and submit same to the Authority.

## 1.5 Bacteria Testing

- 1.5.1. Each completed unit of water main over twenty feet (20') in length shall be thoroughly sterilized with chlorine before it's place into operation. The amount applied shall be at least 50 ppm. The contact period shall be at least 16 hours but shall not exceed 48 hours.
- 1.5.2. All valves connected to the Authority's water distribution system shall be operated only by MMUA personnel.
- 1.5.3. The Contractor must receive Authority approval for the method of sterilization planned for use.
- 1.5.4. The maximum length of water main to be sampled is 1200 feet.
- 1.5.5. The valves isolating the main from the existing system should be locked out and tagged out to prevent unintentional release of the elevated chlorine residual water used for disinfection.
- 1.5.6. After flushing has been completed and the chlorine residual is not greater than 0.2 ppm, a bacteriological sample shall be taken in accordance with AWWA guidelines.
- 1.5.7. De-chlorination shall be used when deemed necessary by the Authority.
- 1.5.8. The mouth of the valve, hydrant, blow-off etc., shall be sterilized using a propane torch or equivalent and the water then allowed to flow for a period of not less than 5 minutes.
- 1.5.9. The standard sample shall be collected in sterile bottles care being taken not to contaminate the neck of the bottle or stop per during collection.
- 1.5.10. This sample will then be delivered to a certified laboratory designated by the engineer by the engineer's representative for analysis or sample collected by the certified lab.
- 1.5.11. Copies of the analysis shall be sent to the engineer directly from the laboratories.
- 1.5.12. Bacterial Colony Count shall be zero. In the event that the laboratory analysis shows bacteria present the line shall be re-chlorinated, flushed, sterilized and a new sample taken until such time as the AWWA and NJDEP standards are met.

## 1.6 Sampling Requirements

- 1.6.1. Three (3) samples shall be taken fifteen (15) minutes apart.
- 1.6.2. The lab must indicate the exact location of where the sample was taken. (i.e. street address, nearest cross street, Authority valve number if applicable,)
- 1.6.3. Fire hydrants and hoses are not recommended for the collection of samples but may be permitted with the approval of the Authority Superintendent.

- 1.6.4.** The sampling pipe must be dedicated, clean, disinfected, and flushed prior to sampling.
- 1.6.5.** Samples shall be tested for bacteriological quality and shall show the absence of total coliform, fecal, and E.coli.
- 1.6.6.** Samples should also be tested for acceptable aesthetic quality (chlorine residual, pH, alkalinity, specific conductance, turbidity.).
- 1.6.7.** If the initial sample fails to produce satisfactory bacteriological results, the main may be re-flushed and shall be re-sampled.
- 1.6.8.** If the check samples fail to produce acceptable results, the main shall be re-chlorinated until satisfactory results are obtained.
- 1.6.9.** If a pipeline is not promptly returned to service, the situation should be evaluated by the Authority to determine if the water quality may have been impacted and if additional testing is warranted.

TO:

MONROE MUNICIPAL UTILITIES AUTHORITY  
372 SOUTH MAIN STREET  
WILLIAMSTOWN, NEW JERSEY 08094

DATE: \_\_\_\_\_

ATTN: SUPERINTENDENT

RE: \_\_\_\_\_  
Project  
\_\_\_\_\_  
Section  
\_\_\_\_\_  
As-Built Water

This is to inform you that the water mains referred to above and for which we have requested an inspection for pressure compliance have been disinfected in accordance with the project specifications.

Very truly yours,

Signature: \_\_\_\_\_

Company: \_\_\_\_\_

cc: Monroe Municipal Utilities Authority Executive Director  
File

## SECTION II TESTING OF SANITARY SEWERS

### 2.1 Objective

This procedure establishes the method(s) to be used for the testing of sanitary sewers.

### 2.2 Purpose

The purpose of this procedure is to establish a uniform method and practice in testing sanitary sewers for infiltration, exfiltration, and alignment.

- 2.2.1. All testing shall be performed in the presence of the Authority's Engineer.
- 2.2.2. The contractor must submit complete as-builts of all utilities and appurtenances to the Authority's Engineer prior to the Authority testing any line. Complete as-built information for all gravity sewer mains shall include pipe invert elevations signed and sealed by a New Jersey Licensed Land Surveyor certifying the actual as-built invert elevation constructed.
- 2.2.3. All pressure gauges shall have a minimum pressure range of zero (0) to 1.75 times the required pressure. Gauges with pressure ranges exceeding 2.75 times the required pressure will not be accepted.
- 2.2.4. All pressure gauges shall be calibrated within one (1) calendar year before the date of the test. All calibrations must be traceable to the National Institute of Standards and Technology. The contractor must be able to prove this certification before any testing being conducted.
- 2.2.5. Other methods of testing gravity and sanitary sewer force mains may be used, however, prior approval of the engineer, in writing, must be obtained before the test being performed.

### 2.3 Infiltration Test Procedure (Gravity Sewer)

When testing sanitary sewer lines for infiltration, the following method shall be used:

- 2.3.1. Examine the sanitary sewer system for infiltration at the downstream end of the system after construction has been completed and before any sanitary building connection.
- 2.3.2. In the event that there is infiltration and water is flowing at the downstream end of the system, then the source must be determined.
- 2.3.3. To isolate the source, it is necessary to go upstream one manhole at a time, to find where the flow is originating. This is done by plugging the first upstream manhole and observing to see if the flow stops. This procedure is repeated one manhole at a time

until the infiltration has been isolated.

## **2.4 EXFILTRATION TEST PROCEDURES (GRAVITY SEWER)**

When testing sanitary sewer lines for exfiltration, the following method shall be used:

- 2.4.1.** The low-pressure air test is the most desirable method of testing and should be used when possible. The low-pressure air test is very fast, and isolation of leaks is very precise.
- 2.4.2.** Before the start of the infiltration test, all construction work for the system under test shall be completed. This includes backfilling and completion of all manholes.
  - a.** Low Pressure Air Test (5 psig) to be conducted between two consecutive manholes, as directed by the Engineer.
  - b.** The test section of the sewer line is plugged at each end. One of the plugs used at the manhole must be tapped and equipped for the air inlet connection for filling the line from the air compressor.
  - c.** All service laterals, stubs and fittings into the sewer test section should be properly capped or plugged, and carefully braced against the internal pressure to prevent air leakage by slippage and blowouts.
  - d.** Connect air hose to tapped plug selected for the air inlet. Then connect the other end of the air hose to the portable air control equipment, which consists of valves and pressure gauges used to control:
    - 1.** The air entry rate to the sewer test section, and
    - 2.** To monitor the air pressure in the pipe line.
- 2.4.3.** More specifically, the air control equipment includes a shut-off valve, pressure regulating valve, pressure reduction valve and monitoring pressure gauge having a pressure range from 0 to 10 psi. The gauge should have a minimum division of 0.10 psi and an accuracy of .04 " psi. See Figure No. 1 for typical control equipment apparatus.
- 2.4.4.** Connect another air hose between the air compressor (or other source of compressed air) and the air control equipment. This completes the test equipment set up. Test operations may commence.
- 2.4.5.** Supply air to the test section, slowly, filling the pipe line until a constant pressure of 5 psig is maintained. The air pressure must be regulated to prevent the pressure inside the pipe from exceeding 7.0 psig.
- 2.4.6.** When constant pressure of 5 psig is reached, throttle the air supply to maintain the internal pressure for at least 5 minutes for 8" pvc main. During this period, it is advisable

to check all capped and plugged fittings with soap solution to detect any leakage at these connections. (See table 1 for times and pipe sizes)

If leakage is detected at any cap or plug, release the pressure in the line and tighten all leaky caps and plugs. Then start the test operation again by supplying air. When it is necessary to bleed off the air to tighten or repair a faulty plug, a new test time interval must be allowed after the pipe line has been refilled.

**TIME REQUIREMENTS FOR AIR TESTING**

PIPE SIZE (In Inches)	TIME Minutes – Seconds
4	2 – 32
6	3 – 50
8	5 – 06
10	6 – 22
12	7 – 39
14	8 – 56
15	9 – 35
16	10 – 12
18	11 – 34
20	12 – 45
21	13 - 30

**TABLE 1**

**2.4.7. Procedures for Making Air Pressure Correction for Ground Water**

- e. An air pressure correction is required when the prevailing ground water is above the sewer line being tested. Under this condition, the air test pressure must be increased .433 psi for each foot the ground water level is above the invert of the pipe.
- f. Determination of Ground Water Elevation
- g. Where ground water is known to exist or is anticipated in the area before the air testing would be conducted, the following procedure is suggested at the time the sewer main and manholes are constructed.
- h. Determine air pressure correction, which must be added to the 3.0 psig normal starting pressure of test, by dividing the vertical height in feet by 2.31. The result gives the air pressure correction in pounds per square inch to be added.

- i. Example: If the vertical height of water from the sewer invert to the top of the water column measures 11.55 feet, the additional air pressure required would be:

$$\frac{(11.55)}{2.31} = 5 \text{ psig}$$

Therefore, the starting pressure of the test would 3.0 plus 5 or 8.0 psig, and the one half pound drop becomes 7.5 psig. There is no change in the allowable drop (0.5 psig) or in the time requirements established for the basic air test.

**2.5 Alignment** shall be done on all gravity sanitary sewer lines.

- 2.5.1. Alignment consists of visually examining inside of pipe between two (2) consecutive manholes with the aid of a light and mirror.
- 2.5.2. A light is shown from one manhole towards the other manhole.
- 2.5.3. A mirror is held at the invert of pipe and adjusted so the light and barrel of pipe can be seen.
- 2.5.4. The barrel of the pipe shall have no vertical deflection and at least 75% of the barrel shall be visible in the horizontal direction.
- 2.5.5. In the event that alignment shows the pipe not laid true and to grade it shall be repaired and be aligned as necessary until the alignment complies with these requirements.

**2.6. P.V.C. SEWER PIPE DEFLECTION TEST**

This procedure establishes the method to be used when testing P.V.C. sanitary sewer pipe for maximum allowable pipe deflection (reduction in vertical inside diameter). The maximum allowable pipe deflection (reduction in vertical inside diameter) shall be 7.5%.

**2.6.1. Circumstances Warranting Deflection Test**

- 2.6.1.1. Deflection testing will be employed if one or more of the following conditions are known to exist.
- a. Improper construction practices are evident.
  - b. Questionable embedment materials.
  - c. Severe trench construction conditions were encountered.
  - d. Other inspection or testing methods have indicated unacceptable installation condition.

2.6.1.2. The Engineer reserves the right to require that deflection testing be performed at his direction.

**2.6.2. Testing Methods**

When testing P.V.C. sanitary sewer pipe for deflection, the following method shall be used: on the complete installation by mean of the following, before the acceptance of construction.

- a. "GO - NO - GO" Mandrel properly sized
- b. Calibrated television

**2.6.3. Sizing "GO - NO - GO" Mandrel**

2.6.3.1. When establishing the desired dimension for "GO-NO-GO" Mandrels used to test installed P.V.C sewer lines, the desired deflection limit is simply (7-1/2%) subtracted from the base inside diameter to establish the maximum outside diameter of the test mandrel. Base inside diameter for deflection measurements of ASTM D3034-21 SDR 35 PVC sewer pipe are as follows:

**BASE INSIDE DIAMETERS FOR DEFLECTION MEASUREMENTS**  
**OF ASTM D3034 SDR 35 PVC SEWER PIPE**

Size	SDR	Avg. O.D.	1.06 X Min.	Avg. I.D.	Tol. Pkg.	Base I.D.
6"	35	6.275	0.1908	5.915	0.151	5.764
8"	35	8.400	0.2544	7.920	0.226	7.694
10"	35	10.500	0.3180	9.900	0.301	9.599
12"	35	12.500	03816	11.780	0.376	11.404
15"	35	15.300	0.4632	14.426	0.476	13.950

**TABLE 2**

NOTE: Base I.D. is a pipe I.D. derived by subtracting a statistical tolerance package from the pipe's average I.D. The tolerance package is defined as the square root of the sum of squared standard manufacturing tolerances.

Avg. I.D. = Avg. O.D. - 2(1.06) t

Tolerance Package =  $\sqrt{A^2 + B^2 + B^2 + C^2}$

Where: A = O.D. Tolerance (ASTM D-3034)

B = Excess Wall Thickness Tolerance = 0.06 t  
 C = Out-of-Roundness Tolerance = 0.015 (Avg. O.D.)  
 t = Minimum Wall Thickness (ASTM D-3034)

**2.6.3.2.** Calculations necessary to determine the maximum diameter for a "GO-NO-GO" test mandrel to be used in the deflection testing of 8" PVC sewer pipe (ASTM D-3034 DR 35) with the design deflection limit of 7-1/2% shall be done as follows:

$$\text{Mandrel O.D.} = \frac{[100 - Y]}{100} \times \text{Base I.D.}$$

Where: Y = Deflection Limit, %

$$\text{Mandrel O.D.} = \frac{[100 - 7.5]}{100} \times 7.665$$

$$\text{Mandrel O.D.} = 7.09 \text{ inches}$$

Table 3 below shows the mandrel size for the various pipe sizes, based on calculations derived from the above formula.

**BASE INSIDE DIAMETERS AND 7-1/2% DEFLECTION MANDREL DIMENSIONS**

Nominal Deflection Size (in.)	Average I.D. (in.)	Base I.D. (in.)	7 ½% Mandrel O.D. (in.)
6	5.893	5.764	5.31
8	7.891	7.694	7.09
10	9.864	9.599	8.84
12	11.737	11.404	10.51
15	14.374	13.950	12.86

**TABLE 3**

**2.7 TELEVISION INSPECTION**

**2.7.1.** Television inspection shall be employed as the method of final inspection of the interior of the sewers.

**2.7.2.** The system to be furnished by the Contractor shall include all required television equipment, related equipment, electrical power to operate the equipment, trained personnel, and all floats, cables reels, footage, counting devices, lights and other materials necessary to perform the inspection.

- 2.7.3.** The equipment used shall produce a clear, sharp image on the monitor screen. Any equipment not producing a satisfactory result on the monitor screen shall be replaced with another unit. The personnel operating the equipment shall be thoroughly familiar with the operation of the equipment and in interpreting the visual results obtained.
- 2.7.4.** Any irregularities in the pipe such as cracks, misalignment (horizontal or vertical) or poor joints, shall be corrected by the Contractor at his expense before acceptance of the project or for final payment.

## **2.8**    **EXFILTRATION (FORCE MAIN & PRESSURE LINES)**

- 2.8.1.** All force mains and pressure lines shall be tested at 50 psig or 2 times the operating pressure whichever is greater or as required by the specifications.
- 2.8.2.** Each section of pipe shall be slowly filled with water. Before applying the specified test pressure, all air shall be expelled from the pipe through blow-offs or taps that may be required for the release of air at the highest points.
- 2.8.3.** When the test pressure has been reached, the amount of make-up water to maintain the test pressure in one hour shall be measured.
- 2.8.4.** No pipe installed will be accepted with any leakage.
- 2.8.5.** Where sections of pipeline fail to meet this requirement, they shall be required, again maintained under pressure in one hour and retested as necessary until these requirements are complied with.

End of Appendix A

*SAMPLE FORMS*  
*FOR*  
*MONROE MUNICIPAL UTILITIES AUTHORITY*  
*(SUPPLEMENTING THE ADOPTED RULES AND REGULATIONS)*

APPENDIX "B"

March 2005

Revised 05/2024

THIS APPLICATION MUST BE COMPLETED IN ITS ENTIRETY INCLUDING ALL REQUIRED FEES.

FORM A APPROVAL WILL REMAIN VALID FOR A PERIOD OF TWO YEARS FROM THE DATE OF APPROVAL. IF NO FORM B APPLICATION HAS BEEN SUBMITTED WITHIN THE TWO YEAR PERIOD, THE FORM A APPROVAL WILL EXPIRE AND ANY FUNDS REMAINING IN THE ESCROW ACCOUNT WILL BE RETURNED TO THE APPLICANT.

# FORM A

Monroe Municipal Utilities Authority  
372 South Main Street, Williamstown, NJ 08094  
Telephone No.: 856-629-1444  
Fax No.: 856-875-9469  
Email: [info@monroemuanj.com](mailto:info@monroemuanj.com)  
Website: [www.monroemuanj.com](http://www.monroemuanj.com)

Please Circle:

COMMERCIAL

INDUSTRIAL

MAJOR SUBDIVISION

## FORM A: APPLICATION FOR REPORT ON FEASIBILITY OF PUBLIC SEWER AND/OR WATER, RECOMMENDATIONS AND CONDITIONS

*PURPOSE: To determine the economic and technical feasibility of extending public sewer and/or water service to the municipal system. The approval of this application is the first step in obtaining MMUA Endorsement. The applicant should be aware that application approval does not guarantee availability of water and/or sewer.*

**APPLICATION FEE:** \$100.00 – Sewer; \$100.00 – Water; (Check must be made payable to Monroe MUA)

**ESCROW AGREEMENT:** The attached **MMUA ESCROW AGREEMENT** must be completed and returned with this application. Review will not be initiated until document is signed and returned by applicant to the Monroe Municipal Utilities Authority.

**REVIEW FEE:** \$2,500.00 minimum fee to be deposited into escrow fund for professional/administrative evaluation. Applicant is responsible for review fees that exceed the amount originally escrowed at the time of the submittal of this application. (Re: Escrow Agreement, Section 4)

### **APPLICANT:**

Name: \_\_\_\_\_

Address: \_\_\_\_\_

Telephone: \_\_\_\_\_ Fax: \_\_\_\_\_

Email: \_\_\_\_\_

**PROJECT TO BE SERVICED:**

Name: \_\_\_\_\_

Location: \_\_\_\_\_

Area of Entire Tract: \_\_\_\_\_

No. of Lots: \_\_\_\_\_ Tax Map Plate: \_\_\_\_\_ Block: \_\_\_\_\_ Lot: \_\_\_\_\_

Type: **(Check)** Single Family Homes: \_\_\_\_\_ Townhouses: \_\_\_\_\_

Apartments: \_\_\_\_\_ Condominiums: \_\_\_\_\_

No. of Units: \_\_\_\_\_ (regarding above if applicable)

Industrial: \_\_\_\_\_ (Square Footage): \_\_\_\_\_

Commercial: \_\_\_\_\_ (Square Footage): \_\_\_\_\_

Professional: \_\_\_\_\_ (Square Footage): \_\_\_\_\_

Other: \_\_\_\_\_ (Describe): \_\_\_\_\_

**PROJECT PLANS:**

Construction Start Date: \_\_\_\_\_ Duration of Project: \_\_\_\_\_

**PROFESSIONAL ENGINEER DESIGNING WATER/SEWER SYSTEM:**

Name: \_\_\_\_\_

Signature & Seal

Address: \_\_\_\_\_

Telephone: \_\_\_\_\_ Fax: \_\_\_\_\_

Email: \_\_\_\_\_

**DESCRIPTION OF PROPOSED SYSTEMS:**

Water: (Approximate distance to nearest source) \_\_\_\_\_

Sewer: (Approximate distance to nearest source) \_\_\_\_\_

**SUPPORTING DATA REQUIRED:**

- ✓ Two copies of general location plan showing streams, streets, blocks, lots and tax map numbers.
- ✓ Proposed system outlines and route of construction.
- ✓ Estimated volume of flow \_\_\_\_\_
- ✓ For Commercial and Industrial applicants, see Section 7 of the Rules & Regulations for additional supporting data.

**FINAL APPROVAL WILL NOT BE GRANTED UNLESS ALL REQUIREMENTS HAVE BEEN RECEIVED.**

\_\_\_\_\_  
PRINT NAME

\_\_\_\_\_  
SIGNATURE OF APPLICANT

\_\_\_\_\_  
DATE

**FOR OFFICE USE ONLY:**

**ACTION:** 1. Escrow Agreement between applicant and Authority signed: \_\_\_\_\_



**MONROE MUNICIPAL UTILITIES AUTHORITY  
ESCROW AGREEMENT**

**THIS AGREEMENT**, made this \_\_\_\_\_ day of \_\_\_\_\_, 202\_\_\_, by and between MONROE MUNICIPAL UTILITIES AUTHORITY, with principal offices located at 372 South Main Street, Williamstown, Township of Monroe, County of Gloucester and State of New Jersey (the “MMUA”), and \_\_\_\_\_, with principal offices located at \_\_\_\_\_ (the “Applicant”) (the MMUA and Applicant referred to collectively as, the “Parties”).

**WITNESSETH**

**WHEREAS**, the Applicant seeks approval from the MMUA for the land development project known as: \_\_\_\_\_ (the “Project”), located at \_\_\_\_\_, identified on the Township of Monroe Tax Map as Block(s) \_\_\_\_\_, Lot(s) \_\_\_\_\_ (the “Property”); and

**WHEREAS**, the Municipal and County Utilities Authorities Law (“MCUAL”), N.J.S.A. 40:14B-20 et seq., permits the MMUA to adopt rules and regulations for the management and regulation of its business and affairs; and

**WHEREAS**, the MCUAL further empowers the MMUA to require persons to deposit money for professional services, inspection fees, and to satisfy any performance or maintenance

guarantee requirements applicable to a project and/or development; N.J.S.A. 40:14B-20.1; and

**WHEREAS**, the MMUA has adopted rules and regulations as permitted by the MCUAL known as the “MMUA Rates, Rules, and Regulations Applicable to Sewerage and Water Service in the Township of Monroe, County of Gloucester, State of New Jersey” (“MMUA Rules & Regulations”); and

**WHEREAS**, Section 6 of the MMUA Rules and Regulations requires the Applicant to establish an escrow account and enter into an escrow agreement with the MMUA whereby work required performed by the MMUA’s professionals on the Project will be paid for by the Applicant from the escrow account; and

**WHEREAS**, the Parties agree it is appropriate to reduce this understanding to writing.

**NOW, THEREFORE**, for and in consideration of the mutual promises and covenants herein contained, the Parties agree as follows:

**Section 1. PURPOSE.**

**1.1.** The MMUA authorizes its professional and administrative staff to review, inspect, report and study all plans, documents, statements, improvements, and provisions made by the APPLICANT. The MMUA directs its professional staff and administrative staff to make all oral and/or written reports/communications to the MMUA of its conclusions and findings derived from the review, study, investigation and like or similar duties performed as elsewhere authorized, including professional time allocated to such application at the MMUA's regular and special meetings. The APPLICANT agrees to pay all professional and administrative fees incurred by the MMUA for the performance of the duties outlined above.

**Section 2. ESCROW ESTABLISHED**

**2.1.** In the event the escrow fund to be established is for an amount which is \$5,000 or less, the APPLICANT and MMUA, in accordance with the provisions of this Agreement and Sections 6 and of the MMUA's Rules and Regulations, hereby agree to create and establish the escrow with the designated Financial Officer of the MMUA.

**2.2.** In the event the escrow fund to be established is for an amount which exceeds \$5,000, the APPLICANT AND MMUA, in accordance with the provisions of this Agreement, Sections 6 of the MMUA Rules and Regulations and N.J.S.A. 40:14B-20.1, hereby agree to create and establish the escrow as follows:

- (a) the MMUA shall deposit the escrow fund in a banking Institution or savings and loan association in the State of New Jersey insured by an agency of the Federal Government, or in any other fund or depository approved for such deposits by the State of New Jersey, in an account bearing interest at a minimum at the rate currently paid the institution or depository on time or savings deposits;
- (b) the MMUA shall notify the APPLICANT in writing of the name and address of the institution or depository in which the deposit is made and the amount of the deposit; and
- (c) the MMUA shall not be required to refund an amount of interest paid on a deposit which does not exceed \$100.00 for the year. If the amount of interest exceeds \$100.00, that entire amount shall belong to the person and shall be refunded to him, her or it by the MMUA annually or at the time the deposit is repaid or applied to the purposes for which it was deposited, as the case may be; except that the MMUA may retain for administrative expenses a sum equivalent to no more than 33 1/3% of that entire amount, which shall be in lieu of all other administrative and custodial expenses.

### **Section 3. ESCROW FUNDED**

**3.1.** Applicant by execution of this Agreement, shall pay to the MMUA, to be deposited as described in Section 2, such sum as are required by the MMUA Rules & Regulations and each and for every Agreement entered into by the Parties.

### **Section 4. INCREASE IN ESCROW FUND**

**4.1.** If during the existence of this Escrow Agreement the funds held by the escrow holder shall be insufficient to cover any voucher or bill submitted by the professional staff and reviewed and approved by the MMUA, then the APPLICANT shall, within fourteen (14) days from the date of receipt of written notice by the MMUA, deposit additional sum, as per request of the escrow holder to cover the amount of the deficit. The written notice referred to in this paragraph shall be sent to APPLICANT unless otherwise shown, receipt shall be presumed upon mailing.

**4.2.** During such time that the APPLICANT'S escrow account is lacking funds sufficient to cover any voucher or bill submitted by the MMUA's professional or administrative staff and/or is otherwise delinquent, the MMUA:

- (a) shall direct its professional and administrative staff to perform no further review, work, inspections, or activity of any kind related to the Project;
- (b) shall not accept any new applications submitted by the Applicant related to the Project; and

- (c) shall not issue any permits and/or approvals related to the Project to which the APPLICANT may otherwise be entitled.

**4.3.** The MMUA's professional and administrative staff may resume work related to the Project and the MMUA may begin accepting applications related to the Project and issuing any permits or approvals to which the APPLICANT may be entitled at such time the APPLICANT'S escrow account is replenished and returned to good standing.

## **Section 5. BOARD OF REVIEW**

**5.1.** The designated Financial Officer of the MMUA shall review the vouchers submitted by the professionals to determine whether the services have been performed in the manner and to the degree required by this Agreement. Upon making a determination that said services have been performed properly, said official shall process said vouchers in the same manner and under the same terms as are normally employed for vouchers submitted for work performed on behalf of the MMUA. At the conclusion of this processing, the amounts specified in said vouchers shall be deducted by the escrow holder from the escrow established pursuant to this Agreement and MMUA's Rules and Regulations.

## **Section 6. CONTEST OF REASONABLENESS**

**6.1.** APPLICANT agrees that the reasonableness of any fee or charge may be challenged by an appropriate legal action brought within forty-five (45) days from the date that the APPLICANT'S escrow deposit balance is returned or forty-five (45) days from the date the developer receives notice that additional payments are requested to pay charges and fees not covered by the escrow deposits.

**6.2.** APPLICANT understands and agrees that the aforesaid procedure shall be the sole and exclusive method of challenging the reasonableness of charges and fees and hereby waives any longer statute of limitations.

## **Section 7. COLLECTION**

**7.1.** Should the Applicant fail to pay any sum required to be paid hereunder when due, Section 4.2 herein shall apply, and the MMUA may otherwise pursue any and all available remedies to which it may be entitled by law or equity.

## **Section 8. INTEREST ALLOCATIONS**

**8.1.** Any and all interest which would result from or arise out of the deposits being made and held in escrow by the APPLICANT shall revert to the use and enjoyment of the escrow holder as compensation for the services rendered in connection with this Escrow Agreement, unless otherwise specified in Section 2 pertaining to the escrow funds exceeding \$5,000.00.

## **Section 9. GUARANTEE**

**9.1.** In the event that the APPLICANT fails to comply with all of the terms and conditions of this Agreement, the MMUA is authorized to pursue all of the remedies against the guarantors to this Agreement as if the guarantors were, in fact, the APPLICANT.

**9.2.** The guarantors agree to be bound by all of the terms and conditions of the Agreement. The guarantors further agree to provide to the MMUA, at its discretion, sufficient financial information to assure the MMUA that the guarantors can satisfy the financial obligations of the APPLICANT should they be in default. The guarantors shall be the financial obligations of the APPLICANT should they be in default. The guarantors shall be the principals, partners or corporate officers, as well as the spouses of the APPLICANT, or such other parties as the MMUA deems appropriate.

## **Section 10. TRANSFER OF FUNDS**

**10.1.** For the duration of the Project, the APPLICANT shall not transfer ownership of the Project or Property to a third-party nor shall the APPLICANT assign its interest and obligations established by this Agreement to a third-party without the express, written approval of the MMUA.

**10.2.** In the event the MMUA approves of the APPLICANT'S transfer of ownership of the Project or Property to a third-party, the APPLICANT and third-party shall execute an assignment agreement assigning this Agreement and the interests and obligations therein from the APPLICANT to the third-party. The MMUA shall be named as a direct beneficiary, party, and signatory to the aforementioned assignment agreement.

**10.3.** In the event ownership of the Project or Property is transferred and/or this Agreement is assigned in accordance with the foregoing sections, the Escrow Account associated with the Project established pursuant to this Agreement shall remain in effect and kept in good standing by the APPLICANT. The same escrow account will stay in effect for the entire duration of the Project. The MMUA shall reimburse the third-party owner and not the APPLICANT with the balance in the escrow account at the conclusion of the Project.

**[ SIGNATURES ON FOLLOWING PAGE ]**

ATTEST:

MONROE MUNICIPAL UTILITES AUTHORITY

\_\_\_\_\_

\_\_\_\_\_

CHAIRMAN

ATTEST:

\_\_\_\_\_  
*(applicant name)*

\_\_\_\_\_

*(signature)* \_\_\_\_\_

*(name)* \_\_\_\_\_

*(title)* \_\_\_\_\_

Revised 05/2024

THIS APPLICATION MUST BE COMPLETED IN ITS ENTIRETY INCLUDING ALL REQUIRED FEES.

FORM B APPROVAL WILL REMAIN VALID FOR A PERIOD OF TWO YEARS FROM THE DATE OF APPROVAL UNLESS A TREATMENT WORKS APPROVAL PERMIT (TWA PERMIT) IS ISSUED BY THE NJDEP. IF A TWA PERMIT IS ISSUED, THE FORM B APPROVAL WILL REMAIN VALID FOR AS LONG AS THE TWA PERMIT REMAINS IN EFFECT. THE FORM B APPROVAL SHALL EXPIRE CONCURRENTLY WITH THE EXPIRATION OF THE TWA PERMIT.

# FORM B

Monroe Municipal Utilities Authority  
372 South Main Street, Williamstown, NJ 08094  
Telephone No.: 856-629-1444  
Fax No.: 856-875-9469  
Email: [info@monroemuanj.com](mailto:info@monroemuanj.com)  
Website: [www.monroemuanj.com](http://www.monroemuanj.com)

Please Circle:

COMMERCIAL

INDUSTRIAL

MAJOR SUBDIVISION

## FORM B: APPLICATION FOR PRELIMINARY REVIEW OF PLANS FOR PUBLIC SEWER AND/OR WATER

*PURPOSE: This application and supporting data specifying the engineering details of the proposed project will be analyzed for compliance with the Authority Engineer's standards including provisions for orderly growth. The final condition of approval will be memorialized in the DEVELOPER AGREEMENT between the applicant and Authority regarding the terms and conditions for providing sewer and/or water services.*

The applicant should be aware that application approval does not guarantee availability of water and/or sewer.

**FILING FEE:** \$200.00 – Sewer; \$200.00 – Water; (Check must be made payable to Monroe MUA)

**REVIEW FEE:** A review fee of \$5,000.00 is due at the time of the submittal of this application. The Authority reserves the right to make exceptions to the above requirement when it appears the imposition thereof will be patently inequitable. The Applicant agrees to be responsible for all MMUA review costs, in association, including costs that exceed the original escrow deposit. (Re: Escrow Agreement, Section 4)

### **APPLICANT:**

Name: \_\_\_\_\_

Address: \_\_\_\_\_

Telephone: \_\_\_\_\_ Fax: \_\_\_\_\_

Email: \_\_\_\_\_

**PROJECT TO BE SERVICED:**

Name: \_\_\_\_\_

Location: \_\_\_\_\_

No. of Lots: \_\_\_\_\_ Tax Map Plate: \_\_\_\_\_ Block: \_\_\_\_\_ Lot: \_\_\_\_\_

Type: **(Check)** Single Family Homes: \_\_\_\_\_ Townhouses: \_\_\_\_\_

Apartments: \_\_\_\_\_ Condominiums: \_\_\_\_\_

No. of Units: \_\_\_\_\_ (regarding above if applicable)

Industrial: \_\_\_\_\_ (Square Footage): \_\_\_\_\_

Commercial: \_\_\_\_\_ (Square Footage): \_\_\_\_\_

Professional: \_\_\_\_\_ (Square Footage): \_\_\_\_\_

Other: \_\_\_\_\_ (Describe): \_\_\_\_\_

**DEVELOPMENT PLANS:**

Construction Start Date: \_\_\_\_\_ Duration of Project: \_\_\_\_\_

**PROFESSIONAL ENGINEER DESIGNING WATER/SEWER SYSTEM:**

Name: \_\_\_\_\_

Signature & Seal

Address: \_\_\_\_\_

Telephone: \_\_\_\_\_ Fax: \_\_\_\_\_

Email: \_\_\_\_\_

**SUPPORTING DATA REQUIRED:**

Department of Environmental Protection application for sewer and water permits which shall include:

- ✓ Two copies of NJDEP Applications and one in PDF Format **(Not originals)**
- ✓ Two copies of Site Plans/Subdivision Plans and one in PDF Format **(Complete sets)**
- ✓ Two copies of Narrative Engineer’s Reports and one in PDF Format **(Sanitary Sewer & Water)**

- ✓ Two copies of the Construction Specifications and one in PDF Format (**Sanitary Sewer & Water**)
- ✓ Commercial and Industrial Applicants see Section 7 of the Rules & Regulations for additional supporting data.

**FINAL APPROVAL WILL NOT BE GRANTED UNLESS ALL REQUIREMENTS HAVE BEEN RECEIVED.**

---

PRINT NAME

---

SIGNATURE OF APPLICANT

---

DATE

**FOR OFFICE USE ONLY:**

**ACTION:**

1. Prior to Board Approval MMUA Developer Agreement must be executed by MMUA and applicant.
2. Final stamped plans must be received by Authority.
3. Resolutions shall be approved.

Revised 05/2024

THIS APPLICATION MUST BE COMPLETED IN ITS ENTIRETY INCLUDING ALL REQUIRED FEES.

# FORM C

Monroe Municipal Utilities Authority  
372 South Main Street, Williamstown, NJ 08094  
Telephone No.: 856-629-1444  
Fax No.: 856-875-9469  
Email: [info@monroemuanj.com](mailto:info@monroemuanj.com)  
Website: [www.monroemuanj.com](http://www.monroemuanj.com)

Please Circle:

COMMERCIAL

INDUSTRIAL

MAJOR SUBDIVISION

## FORM C: APPLICATION FOR CONSTRUCTION OF PUBLIC SEWER AND/OR WATER SYSTEM

*PURPOSE: To control the extent and schedule of planned sewer and/or water facility installations and to establish a schedule for Authority inspection of completed installations.*

The applicant should be aware that application approval does not guarantee availability of water and/or sewer.

**FILING FEE:** \$200.00 – Sewer; \$200.00 – Water; (Check must be made payable to Monroe MUA)

**REVIEW FEE:** A review fee of \$5,000.00 is due at the time of the submittal of this application. The Authority reserves the right to make exceptions to the above requirement when it appears the imposition thereof will be patently inequitable. The Applicant agrees to be responsible for all MMUA review costs, in association with this application, including costs that exceed the original escrow deposit. (Re: Escrow Agreement, Section 4)

### PART I

#### **APPLICANT:**

Name: \_\_\_\_\_

Address: \_\_\_\_\_

Telephone: \_\_\_\_\_ Fax: \_\_\_\_\_

Email: \_\_\_\_\_

#### **PROJECT TO BE SERVICED:**

Name: \_\_\_\_\_

Location: \_\_\_\_\_

Section: \_\_\_\_\_ No. of Lots: \_\_\_\_\_

Date of Form B Approval: \_\_\_\_\_

**PROFESSIONAL ENGINEER DESIGNING WATER/SEWER SYSTEM:**

Name: \_\_\_\_\_

Signature & Seal

Address: \_\_\_\_\_

Telephone: \_\_\_\_\_ Fax: \_\_\_\_\_

Email: \_\_\_\_\_

**SUPPORTING DATA REQUIRED:**

- ✓ Applicant Engineer's Itemized Report on total sewer and/or water construction costs including fire hydrants \$ \_\_\_\_\_
- ✓ If required, two (2) complete sets of fire protection plans/including approval of said documents in writing from the Monroe Township Fire Subcode Official.
- ✓ Two (2) sets of NJDEP approved plans. Project Professional Engineer shall sign, seal and certify a letter attesting that the plans submitted are identical to the Form B approved plans. However, should there be revisions to the plans, the Engineer will submit a letter explaining in detail each revision with the basis and justification for each revision.
- ✓ Two (2) complete sets of stamped final construction plans approved by the Township of Monroe.
- ✓ One copy of the Township Resolution approving the project.
- ✓ Typed list coordinating individual tax lot and block with street addresses.
- ✓ Two copies each of easement plans and descriptions. A separate legal description and plan of easement shall be prepared for each lot affected by water and/or sanitary sewer facilities to be constructed on private property.

**PART II**

When the Authority Engineer has verified the total estimated sewer and water construction costs and the Authority Board has reviewed the plans, the applicant will be notified to submit the following:

- ✓ REVIEW AND INSPECTION FEE: (Payable to MMUA: to be escrowed). 5% of verified construction costs: Fee to cover engineering fees, legal fees, inspection fees and related expenses.

- ✓ Performance Bond, cash or certified check: 120% of total sewer and water construction costs. (See attached samples)

**FINAL APPROVAL WILL NOT BE GRANTED UNLESS ALL REQUIREMENTS HAVE BEEN RECEIVED.**

---

PRINT NAME

---

SIGNATURE OF APPLICANT

---

DATE

**REQUEST FOR WATER AND/OR SEWER PERMITS**  
(SUBMIT 48 HOURS PRIOR TO OBTAINING PERMITS)

MONROE MUNICIPAL UTILITIES AUTHORITY  
372 South Main Street, Williamstown, NJ 08094  
Telephone No.: 856-226-3628  
Fax No.: 856-875-9469  
Email: [info@monroemuanj.com](mailto:info@monroemuanj.com)  
Website: [www.monroemuanj.com](http://www.monroemuanj.com)

Dear Ms. Gaudio,

Enclosed you will find \_\_\_\_\_ checks made payable to \_\_\_\_\_ totaling \$ \_\_\_\_\_, which represents payment in full of the sewerage and/or water connection fees for the following units for which sewer and/or water permits are hereby requested at this time. (A copy of applicable permit fees is attached for the applicant's reference.)

NAME OF DEVELOPMENT: \_\_\_\_\_

SECTION: \_\_\_\_\_

<u>BLOCK NO.</u>	<u>LOT NO.</u>	<u>STREET ADDRESS</u>	<u>BLOCK NO.</u>	<u>LOT NO.</u>	<u>STREET ADDRESS</u>
_____	_____	_____	_____	_____	_____
_____	_____	_____	_____	_____	_____
_____	_____	_____	_____	_____	_____
_____	_____	_____	_____	_____	_____

I understand that any sewer and/or water permits issued for any residential unit pursuant to the foregoing request shall be valid for a period of one (1) year from the date of issuance and that any sewer and/or water permit issued for an industrial/commercial unit shall be valid for a period of one (1) year from the date of issuance.

I understand that the Developer and all agents, successors, and assigns of Developer, must demonstrate proof that the required deed with deed restriction has been recorded and complied with prior to the issuance of the water and sewer permit(s) from the MMUA for each individual address.

Name of Applicant: \_\_\_\_\_

Address: \_\_\_\_\_

Phone: \_\_\_\_\_ Date: \_\_\_\_\_

**ACTION BY MONROE MUNICIPAL UTILITIES AUTHORITY**

Date of Issuance: \_\_\_\_\_ Expiration Date: \_\_\_\_\_

Disapproved: Date: \_\_\_\_\_ Reasons: \_\_\_\_\_

Date: \_\_\_\_\_ Approved: \_\_\_\_\_

Wendy Mahoney, Executive Director

Block(s) \_\_\_\_\_ Lot(s) \_\_\_\_\_

### PERFORMANCE SURETY BOND

We, \_\_\_\_\_, having offices at \_\_\_\_\_, \_\_\_\_\_, as principal, and \_\_\_\_\_, having offices at \_\_\_\_\_, \_\_\_\_\_, a corporation duly licensed to transact a surety business in the State of New Jersey, as surety, are indebted to the Monroe Municipal Utilities Authority in the County of Gloucester, State of New Jersey, obligee ("Authority"), in the sum of \$ \_\_\_\_\_, for \_\_\_\_\_ (name of project and reference if water and/or sanitary sewer or pump station) which payment we bind ourselves and our respective heirs, legal representatives, successors, and assigns, jointly and severally.

On \_\_\_\_\_ (date), principal was granted approval by the Authority for \_\_\_\_\_, (include reference to specific project, and/or phase or section of development). The estimate by the Authority Engineer of the cost of this work and the resolution of approval are attached hereto and made a part hereof.

The principal hereby furnishes a performance surety bond in the amount of \$ \_\_\_\_\_ (not to exceed 120 percent of the cost of the improvements, as certified by the Authority Engineer), written by \_\_\_\_\_, a surety licensed in the State of New Jersey, guarantying full and faithful completion of improvements approved by the Authority in accordance with the applicable Rules and Regulations of same, in lieu of completing the required improvements prior to the granting of final approval. This bond shall remain in full force and effect until such time as all improvements covered by the bond have been approved or accepted by resolution of the Authority, except that in those instances where some of the improvements are approved or accepted by resolution of the Authority upon certification by the Authority Engineer, partial release from the bond shall be granted in accordance with N.J.S.A. 40:55D-53. The amount of the bond remaining shall be sufficient to secure provision of the improvements not yet approved; provided, however, that the Authority may require that 25 percent of the amount of the bond be retained to ensure completion of all improvements.

This bond shall remain in full force and effect until released by resolution of the Authority.

This bond is issued subject to the following conditions:

1. This bond shall not be subject to cancellation either by the principal or by the surety for any reason until such time as all improvements subject to the bond have been accepted by the Authority, in accordance with the applicable provisions of the Municipal Land Use Law.

2. This bond shall be deemed to be continuous in form and shall remain in full force and effect until the improvements are accepted by the Authority and the bond is released, or until default is declared, or until the bond is replaced by another bond meeting applicable legal requirements. Upon approval or acceptance of all improvements by the Authority, or upon replacement of this bond by another bond, liability under this bond shall cease. Upon approval or acceptance of some, but not all, of the required improvements by the Authority, partial release from the bond shall be granted in accordance with N.J.S.A. 40:55D-53; provided, however, that

the portion of the bond amount sufficient to secure completion of the improvements shall continue in effect and the Authority may retain 25 percent of the bond amount posted in order to ensure such completion.

3. The aggregate liability of the surety shall not exceed the sum set forth above.

4. In the event that the improvements subject to this bond are not completed within the time allowed under the conditions of the approval issued, including such extensions as may be allowed by the Authority, the Authority may, at its option, and upon at least 30 days prior written notice to the principal and to the surety by personal delivery or by certified or registered mail or courier, declare the principal to be in default and, in the event that the surety fails or refuses to complete the work in accordance with the terms and conditions of the original approval, claim payment under this bond for the cost of completion of the work. However, the 30-day notice shall not apply when the need for the work constitutes an emergency affecting the public health, safety, or welfare within the meaning of N.J.S.A. 40A:11-6. In such a case, prior written notice to the principal and surety shall be for a period of time reasonable and necessary under the particular circumstances and specified by the Authority. In the event that any action is brought against the principal under this bond, written notice of such action shall be given to the surety by the Authority by personal delivery or by registered or certified mail or courier at the same time.

5. The surety shall have the right to complete the work in accordance with the terms and conditions of the original approval, either with its own employees or in conjunction with the principal or another contractor; provided, however, that the surety, in its sole discretion, may make a monetary settlement with the Authority as an alternative to completing the work.

6. In the event that the principal and the Authority agree to changes in the scope of work, the obligations of the surety under this bond shall not be affected so long as the cost of the work does not exceed 120 percent of the Authority Engineer's certified estimate, attached hereto and made a part hereof, which 120 percent of the estimate shall be the limit of the surety's obligation under this bond in any case. If the cost of the work exceeds 120 percent of the certified estimate, the principal shall secure a rider from a surety for the additional amount; provided, however, that this provision shall not be construed as requiring a surety to provide additional coverage.

7. This bond shall inure to the benefit of the Authority only and no other party shall acquire any rights hereunder.

8. In the event that this bond shall for any reason cease to be effective prior to the approval or acceptance of all improvements, a cease-and-desist order may be issued by the Authority, in which case all work shall stop until such time as replacement guarantee acceptable to the Authority becomes effective.

Date:

\_\_\_\_\_ Witness/Attest: \_\_\_\_\_, Principal

\_\_\_\_\_ Witness/Attest: \_\_\_\_\_, Surety

Block(s) \_\_\_\_\_ Lot(s) \_\_\_\_\_

**IRREVOCABLE STANDBY LETTER OF CREDIT  
(PERFORMANCE)**

Issued by:

Name of Banking Institution: \_\_\_\_\_

Address: \_\_\_\_\_

City/State/Zip: \_\_\_\_\_

Telephone: \_\_\_\_\_ Fax: \_\_\_\_\_

Issue date: \_\_\_\_\_

Expiration date and time: \_\_\_\_\_

Letter of Credit Number: \_\_\_\_\_

Beneficiary:

Name: **Monroe Municipal Utilities Authority**

Address: **372 South Main Street**

City/State/Zip: **Williamstown, NJ 08094**

Telephone: **(856)629-1444**

Applicant:

Name: \_\_\_\_\_

Address: \_\_\_\_\_

City/State/Zip: \_\_\_\_\_

Telephone: \_\_\_\_\_ Fax: \_\_\_\_\_

Amount: \_\_\_\_\_ Dollars: (\$ \_\_\_\_\_)

(Not to exceed 120 percent of the cost of the improvements, as certified by the Authority Engineer).

We hereby issue our irrevocable standby letter of credit in your favor, which is available by your draft at sight bearing our letter of credit number \_\_\_\_\_ on \_\_\_\_\_ (name of banking institution).

Your draft must be presented at the office indicated above by personal delivery or by registered or certified mail or courier and must be accompanied by (1) the original standby letter of credit and any subsequent original amendments and (2) an original statement purportedly signed by the Authority Engineer stating: "The amount of this drawing under Irrevocable Standby Letter of Credit No., \_\_\_\_\_ issued \_\_\_\_\_ by \_\_\_\_\_ (name of banking institution), represents the amount due us as a result of the failure of \_\_\_\_\_ (name of applicant) to complete, in whole or in part, and in accordance with the Authority Rules and Regulations the required site improvements as detailed in the resolution of approval and in that certain Engineer's Estimate entitled " \_\_\_\_\_ "prepared by \_\_\_\_\_ and dated \_\_\_\_\_. I hereby certify that notice of the incompletions upon which this drawing is based was given to the applicant by registered or certified mail or by courier on \_\_\_\_\_ (date

at least 30 days prior to the date of the Authority Engineer's statement, or when the need for the work constitutes an emergency affecting the public health, safety, or welfare within the meaning of N.J.S.A. 40A:11-6, date of written notice to the principal and surety for a period of time reasonable and necessary under the particular circumstances, and accompanied by statement detailing the nature of the emergency)." This certification shall be accompanied by a resolution of the Authority endorsing the findings of the engineer and stating that the improvements have not been approved or accepted.

This letter of credit shall be deemed to be automatically extended annually for periods of one year unless written notice is given by the banking institution by registered or certified mail or by courier to the applicant and the Authority at least 60 days prior to the then-current expiration date.

In the event of the failure of the applicant to furnish another letter of credit meeting the requirements of N.J.S.A. 40:55D-53.5 and N.J.A.C. 5:36-4.3, or other acceptable security, at least 30 days prior to the expiration date of this letter of credit, the Authority may, to the extent allowed by law, draw upon this letter of credit to pay the cost of any incompletions.

This letter of credit shall expire upon approval or acceptance by resolution of the Authority of all improvements cited in the aforesaid Engineer's Estimate or upon replacement of this letter of credit by other security meeting applicable legal requirements. Upon approval or acceptance of some, but not all, of said improvements, a reduction in the amount of this letter of credit shall be granted in accordance with N.J.S.A. 40:55D-53, provided that the remaining amount shall be sufficient to secure provision of the improvements not yet approved and that the Authority may require that the remaining amount be 25 percent of the original amount.

All correspondence to the banking institution concerning this letter of credit shall be addressed to the office indicated above.

This letter of credit shall inure to the benefit of the beneficiary Authority only and no other party shall acquire any rights hereunder.

This letter of credit is subject to [Uniform Customs and Practice for Documentary Credits (1993 Revision), International Chamber of Commerce Publication No. 500] [International Standby Practices 1998 (ISP98)]. (Note: Either shall be acceptable).

We hereby agree with you that drawings under and in compliance with the terms of this letter of credit shall be duly honored upon presentation to us.

\_\_\_\_\_ Witness/Attest: \_\_\_\_\_  
(Authorized Signature and Title)

Monroe Municipal Utilities Authority  
372 South Main Street, Williamstown, NJ 08094  
Telephone No.: 856-629-1444  
Fax No.: 856-875-9469  
Email: [info@monroemuanj.com](mailto:info@monroemuanj.com)  
Website: [www.monroemuanj.com](http://www.monroemuanj.com)

# FORM C-2

## CHANGE IN USE APPLICATION

THIS APPLICATION MUST BE COMPLETED IN ITS ENTIRETY INCLUDING ALL REQUIRED FEES.

**Please Circle:**                      Sewer Only                      Water Only                      Water & Sewer

**REVIEW FEE:** \$50.00: Sewer    \$50.00: Water (Check made payable to Monroe MUA)

DATE: \_\_\_\_\_

**APPLICANT:**

Name: \_\_\_\_\_ Federal Tax ID (Incl W-9): \_\_\_\_\_

Address: \_\_\_\_\_

Telephone: \_\_\_\_\_ Email: \_\_\_\_\_

**PROJECT:**

Name: \_\_\_\_\_

Location: \_\_\_\_\_

Tax Map:            Plate: \_\_\_\_\_ Block: \_\_\_\_\_ Lot: \_\_\_\_\_

Give description of changes to structures/services: \_\_\_\_\_

\_\_\_\_\_  
\_\_\_\_\_

\_\_\_\_\_  
Applicants signature

\_\_\_\_\_  
Authorized MUA signature

**Water & Sewer Connection Fees:**

**Meter Fees:**

Revised 05/2024

THIS APPLICATION MUST BE COMPLETED IN ITS ENTIRETY INCLUDING ALL REQUIRED FEES.

# FORM D

Monroe Municipal Utilities Authority  
372 South Main Street, Williamstown, NJ 08094  
Telephone No.: 856-629-1444  
Fax No.: 856-875-9469  
Email: [info@monroemuanj.com](mailto:info@monroemuanj.com)  
Website: [www.monroemuanj.com](http://www.monroemuanj.com)

Please Circle:

COMMERCIAL

INDUSTRIAL

MAJOR SUBDIVISION

**FORM D: APPLICATION FOR ANY AND ALL OF THE FOLLOWING:**

- A. Final Approval of System
- B. Title transfer of public sewer and/or water systems
- C. Acceptance of Change of Use; Residential, Commercial, Industrial
- D. When applicable, sign off on Operating Permit
- E. Release Escrow

**APPLICATION FEES:** \$200.00 – Sewer; \$200.00 – Water; (Check must be made payable to Monroe MUA)

**REVIEW FEE:** Please note the applicant is responsible for review fees that exceed the amount previously escrowed. Upon notification from the Authority that their escrow account is deficient, the applicant must immediately forward the balance outstanding. Upon Authority acceptance of the system(s), within sixty (60) days, the balance of the escrow monies will be returned to the applicant.

**PART I**

**APPLICANT:**

Name: \_\_\_\_\_

Address: \_\_\_\_\_

Telephone: \_\_\_\_\_ Fax: \_\_\_\_\_

Email: \_\_\_\_\_

**PROJECT TO BE SERVICED:**

Name: \_\_\_\_\_

Location: \_\_\_\_\_

Section: \_\_\_\_\_

Sewer & Water Permit No.: \_\_\_\_\_ Issued: \_\_\_\_\_

Total No. Lots in Section: \_\_\_\_\_ No. Lots Completed: \_\_\_\_\_

HAVE THE STREETS BEEN ACCEPTED BY THE TOWNSHIP? YES \_\_\_\_\_ NO \_\_\_\_\_  
IF YES, COPY OF THE TOWNSHIP RESOLUTION AND TOWNSHIP MAINTENANCE BOND ATTACHED

HOW LONG HAS THE SYSTEM BEEN COMPLETED? \_\_\_\_\_

DOES THE AS-BUILT PLAN FOLLOW EXACTLY THE PLAN SUBMITTED WITH FORM C REGARDING DETAILS AND AREA COVERED? \_\_\_\_\_ IF NOT, INDICATE SIGNIFICANT CHANGES: \_\_\_\_\_

**SUPPORTING DATA REQUIRED, if applicable:**

- ✓ Written request for final inspection.
- ✓ Maintenance Bond (15% of the Construction Cost) guaranteeing satisfactory performance of the system for a period of two (2) years from date of acceptance. (To be submitted after approval of the Form D application.)
- ✓ Certification by the Authority Engineer as to the following:
  - A. The quality and content of the installed system
  - B. That the as-built plans are as herein described
- ✓ Signed and sealed statement from developer that they have satisfied all contractors, subcontractors, and material supplier's liens.
- ✓ Proof of filing of all easements.
- ✓ Applicant must televise the sanitary systems as a prerequisite for approval.
- ✓ Applicant must provide a completed NJDEP construction certification report to be endorsed by the Authority.
- ✓ Applicant must provide As-Built plans in accordance with Section 6.6.3 of the Authority Rules and Regulations.
- ✓ Applicant must provide to the Authority a listing by address, block and lot number of those residents who have sanitary sewer and water cross their property frontage from extension of sanitary sewer and water by this Development.
- ✓ Applicant must provide to the Authority the size of the Sprinkler Line and the number of Sprinkler Heads in building if applicable.

**SCHEDULE:**

Upon request of the applicant for final inspection and/or release of escrow, the MMUA Engineer will conduct a final inspection if applicable. Upon his recommendation to accept the system, the Authority Board of Directors will consider the acceptance of said system by resolution. The MMUA will notify the applicant of Maintenance Bond acceptance, (Amount due with regard to MMUA Data Base Fee), Performance Bond release.

**FINAL APPROVAL WILL NOT BE GRANTED UNLESS ALL REQUIREMENTS HAVE BEEN RECEIVED.**

\_\_\_\_\_  
PRINT NAME

\_\_\_\_\_  
SIGNATURE OF APPLICANT

\_\_\_\_\_  
DATE

Block(s) \_\_\_\_\_ Lot(s) \_\_\_\_\_

### MAINTENANCE SURETY BOND

We \_\_\_\_\_, having offices at \_\_\_\_\_, \_\_\_\_\_, as principal, and \_\_\_\_\_, having offices at \_\_\_\_\_, \_\_\_\_\_, a corporation duly licensed to transact a surety business in the State of New Jersey, as surety, are indebted to the Monroe Municipal Utilities Authority in the County of Gloucester, State of New Jersey, obligee ("Authority"), in the sum of \$ \_\_\_\_\_, for which payment we bind ourselves and our respective heirs, legal representatives, successors, and assigns, jointly and severally.

On \_\_\_\_\_ (date), principal was granted approval by the Authority for \_\_\_\_\_ (include reference to specific job and resolution of approval).

This bond shall become effective upon approval or acceptance of the improvements by the Authority, as certified by the resolution of the Authority, which is, or shall be, attached hereto and made a part hereof. The improvements subject to this bond are as follows:

---

---

The certification of the cost of such improvements by the Authority Engineer is attached hereto and made a part hereof.

The principal, as a condition of approval or acceptance of improvements, hereby furnishes this maintenance bond in the amount of \$ \_\_\_\_\_ not to exceed 15 percent of the cost of the improvements as certified by the Authority Engineer), written by \_\_\_\_\_, a surety licensed in the State of New Jersey, guarantying full and faithful compliance with all terms and conditions of the approval. The bond shall continue in effect for a period of  2  year(s) from the date of approval or acceptance of the said improvements.

This bond is issued subject to the following conditions:

1. This bond shall not be subject to cancellation either by the principal or by the surety for any reason until the end of the period for which it is required to be maintained.
2. The aggregate liability of the surety under this bond shall not exceed the sum set forth above.
3. In the event that the improvements subject to this bond exhibit any defects in functioning, materials or quality of work, the Authority may, at its option, and upon at least 30 days prior written notice to the principal and to the surety by personal delivery or by certified or registered mail or courier, declare the principal to be in default and, in the event that the surety fails or refuses to perform the necessary corrective work, claim payment under this bond for the cost of any work required for the proper correction of any such defects in the said improvements. However, the 30-day notice shall not apply when the need for the work constitutes an emergency affecting the public health, safety, or welfare within the meaning of N.J.S.A. 40A: 11-6. In such a case, prior written notice to the principal and surety shall be for a

period of time reasonable and necessary under the particular circumstances and specified by the Authority. In the event that any action is brought against the principal under this bond, written notice of such action shall be given to the surety by the Authority by personal delivery or by registered or certified mail or courier at the same time.

4. The surety shall have the right to repair any defects in functioning, materials or quality of work and, to that end, to do such corrective work as may be necessary in accordance with the terms and conditions of original approval, either with its own employees or in conjunction with the principal or another contractor; provided, however, that as an alternative to performing such maintenance or corrective work it may, in its sole discretion, make a monetary settlement with the Authority.

5. This bond shall inure to the benefit of the Authority only and no other party shall acquire any rights hereunder.

Date:

\_\_\_\_\_ Witness/Attest: \_\_\_\_\_, Principal

\_\_\_\_\_ Witness/Attest: \_\_\_\_\_, Surety

Block(s) \_\_\_\_\_ Lot(s) \_\_\_\_\_

**IRREVOCABLE STANDBY LETTER OF CREDIT  
(MAINTENANCE)**

Issued by:

Name of Banking Institution: \_\_\_\_\_

Address: \_\_\_\_\_

City/State/Zip: \_\_\_\_\_

Telephone: \_\_\_\_\_ Fax: \_\_\_\_\_

Issue date: \_\_\_\_\_

Expiration date and time: \_\_\_\_\_

Letter of Credit Number: \_\_\_\_\_

Beneficiary:

Name: **Monroe Municipal Utilities Authority**

Address: **372 South Main Street**

City/State/Zip: **Williamstown, NJ 08094**

Telephone: **(856)629-1444**

Applicant:

Name: \_\_\_\_\_

Address: \_\_\_\_\_

City/State/Zip: \_\_\_\_\_

Telephone: \_\_\_\_\_ Fax: \_\_\_\_\_

Amount: \_\_\_\_\_ Dollars: (\$ \_\_\_\_\_)

(Not to exceed 15 percent of the cost of the improvements, as certified by the Authority Engineer)

We hereby issue our irrevocable standby letter of credit in your favor, which is available by your draft at sight bearing our letter of credit number \_\_\_\_\_ on \_\_\_\_\_ (name of banking institution).

Your draft must be presented at the office indicated above by personal delivery or by registered or certified mail or courier and must be accompanied by (1) the original standby letter of credit and any subsequent original amendments and (2) an original statement purportedly signed by the Authority Engineer stating: "The amount of this drawing under Irrevocable Standby Letter of Credit No. \_\_\_\_\_, issued \_\_\_\_\_ by \_\_\_\_\_ (name of banking institution), represents the amount due us as a result of the failure of \_\_\_\_\_ (name of applicant) to take necessary corrective action to repair defects in functioning, materials or quality of work in the required site improvements in accordance with the Authority Rules and Regulations as detailed in the resolution of approval and in that certain Engineer's Estimate entitled " \_\_\_\_\_ "prepared by \_\_\_\_\_ and dated \_\_\_\_\_.

I hereby certify that notice of the defects upon which this drawing is based was given to the applicant by registered or certified mail or by courier on \_\_\_\_\_ (date at least 30 days prior to the date of the Authority Engineer's statement, or when the need for the work constitutes

an emergency affecting the public health, safety, or welfare within the meaning of N.J.S.A. 40A: 1 1-6, date of written notice to the principal and surety for a period of time reasonable and necessary under the particular circumstances, and accompanied by statement detailing the nature of the emergency)." This certification shall be accompanied by a resolution of the Authority endorsing the engineer's findings.

This Letter of Credit shall continue in effect until \_\_\_\_\_ (2 years).

All correspondence to the banking institution concerning this letter of credit shall be addressed to the office indicated above.

This letter of credit shall inure to the benefit of the beneficiary Authority only and no other party shall acquire any rights hereunder.

This letter of credit is subject to [Uniform Customs and Practice for Documentary Credits (1993 Revision), International Chamber of Commerce Publication No. 500] [International Standby Practices 1998 (ISP98)]. (Note: Either shall be acceptable).

We hereby agree with you that drawings under and in compliance with the terms of this letter of credit shall be duly honored upon presentation to us.

\_\_\_\_\_  
(Authorized Signature and Title)

Witness/Attest: \_\_\_\_\_

APPLICATION MUST BE COMPLETED IN ITS ENTIRETY.

# FORM E-A

Monroe Municipal Utilities Authority  
372 South Main Street, Williamstown, NJ 08094  
Telephone No.: 856-226-3628  
Fax No.: 856-875-9469  
Email: [info@monroemuaj.com](mailto:info@monroemuaj.com)  
Website: [www.monroemuaj.com](http://www.monroemuaj.com)

**FORM E-A: APPLICATION FOR CONSTRUCTION OF PUBLIC SEWER AND/OR WATER SYSTEMS INTO EXISTING MMUA SYSTEM FOR ONE OF THE FOLLOWING:**

**Please Circle:**

**RESIDENTIAL**

**COMMERCIAL**

**INDUSTRIAL**

*PURPOSE: To determine the technical and economic feasibility of existing sewer and/or water to the MMUA system and to verify that the systems will be constructed in compliance with the MMUA Rules and Regulations. **If applicable, Superintendent may direct applicant to submit a Form A Application to the Authority.***

**Connection fees to be paid in accordance with the Authority's current Rules and Regulations.**

The Superintendent or his designee is to be present at the time that the MMUA system is connected into. Arrangements must be made prior to such connection to have the MMUA office make a firm appointment for the MMUA Superintendent or his designee to be present.

**APPLICANT:**

Name: \_\_\_\_\_

Address: \_\_\_\_\_

Telephone: \_\_\_\_\_ Fax: \_\_\_\_\_

Email: \_\_\_\_\_

**OWNER INFORMATION:**

Name: \_\_\_\_\_

Address: \_\_\_\_\_

Telephone: \_\_\_\_\_ Fax: \_\_\_\_\_

Email: \_\_\_\_\_

**SERVICE LOCATION:**

Tax Map: Plate \_\_\_\_\_ Block: \_\_\_\_\_ Lot: \_\_\_\_\_

**REGISTERED PLUMBER:**

Name: \_\_\_\_\_ Phone: \_\_\_\_\_

**ESTIMATED DAILY FLOW:** \_\_\_\_\_ **GPD**

**SUPPORTING DATA REQUIRED:**

Two (2) sets of plans of a registered plumber showing proposed line from the dwelling to the MMUA main. Plans must include elevation.

Proof of Road Opening Permit.

Commercial and Industrial applicants see Section 7 for additional supporting data.

**TECHNICAL REQUIREMENTS:**

SEWER - Under no circumstances shall any new fixture be installed in a building lower than the front curb elevation or street centerline elevation, whichever is higher, unless special precautions are incorporated into the new fixture installation to prevent surcharging of the new fixture from the sanitary sewer main from high flow or blockage.

Lateral from the house to the main shall either be cast iron or PVC pipe. The connection to the main shall be through an approved wye or saddle. An MMUA Representative shall be present at the time of the tapping into the MMUA main.

A vertical inspection riser shall be installed in accordance with the attached Detail Sheet.

WATER - Lateral from house to main shall be 1" 'K' copper with a curb stop and box one foot inside the curb. Valves shall be installed on each side of the Meter Yoke. Yoke may be picked up at the MMUA office and shall be installed by the plumber. MMUA shall install a meter with a remote readout.

Signature of Applicant: \_\_\_\_\_ Date: \_\_\_\_\_

THIS APPLICATION MUST BE COMPLETED IN ITS ENTIRETY.

# FORM E-D

Monroe Municipal Utilities Authority  
372 South Main Street, Williamstown, NJ 08094  
Telephone No.: 856-226-3628  
Fax No.: 856-875-9469  
Email: [info@monroemuanj.com](mailto:info@monroemuanj.com)  
Website: [www.monroemuanj.com](http://www.monroemuanj.com)

**FORM E-D APPLICATION PERTAINING TO THE AVAILABILITY OF WATER AND OR SEWER**

Request for written verification without formal review pertaining to the availability of water and sewer utilities for either a residential, a commercial or industrial unit.

**Residential Unit:**

PURPOSE: To determine if service is available with regard to connecting to the MMUA existing sewer and/or water system.

**Industrial or Commercial Unit:**

PURPOSE: To determine if service is available with regard to connecting to the MMUA existing sewer and/or water system.

Please Circle:

RESIDENTIAL

COMMERCIAL

INDUSTRIAL

Seeking availability of:

WATER

SEWER

BOTH WATER & SEWER

**APPLICANT:**

Name: \_\_\_\_\_

Address: \_\_\_\_\_

City, State, Zip: \_\_\_\_\_

Telephone: \_\_\_\_\_ Fax: \_\_\_\_\_

Email: \_\_\_\_\_

**OWNER INFORMATION:**

Name: \_\_\_\_\_

Address: \_\_\_\_\_

City, State, Zip: \_\_\_\_\_

Telephone: \_\_\_\_\_ Fax: \_\_\_\_\_

Email: \_\_\_\_\_

**PROPERTY LOCATION:**

Address: \_\_\_\_\_

Block No.: \_\_\_\_\_ Lot No.: \_\_\_\_\_

PRINT NAME

APPLICANTS SIGNATURE/DATE

# FORM E-D EXEMPT

Monroe Municipal Utilities Authority  
372 South Main Street  
Williamstown, NJ 08094  
Telephone No.: 856-226-3628  
Fax No.: 856-875-9469  
Email: [info@monroemuanj.com](mailto:info@monroemuanj.com)  
Website: [www.monroemuanj.com](http://www.monroemuanj.com)

## APPROVAL OF EXEMPTION TO CONNECT INTO PUBLIC WATER AND SEWER WHERE SERVICE IS NOT AVAILABLE TO SITE.

Please Circle:

RESIDENTIAL

COMMERCIAL

INDUSTRIAL

Please Circle One:

WATER

SEWER

BOTH WATER & SEWER

DATE: \_\_\_\_\_

### APPLICANT:

Name: \_\_\_\_\_

Address: \_\_\_\_\_

City, State, Zip: \_\_\_\_\_

Telephone: \_\_\_\_\_ Fax: \_\_\_\_\_

Email: \_\_\_\_\_

### PROJECT NAME (if other than applicant(s)):

Name: \_\_\_\_\_

Address: \_\_\_\_\_

Tax Map Block No.: \_\_\_\_\_ Lot No.: \_\_\_\_\_

The Applicant has made a request for water and/or sewer service. The Authority has reviewed the request and has determined that the water and/or sewer service is not available to the site.

1. Therefore, the Authority has no objection to the installation of either an on-site disposal system or potable water system providing that all necessary approvals are granted by the appropriate Township, County and State Agencies.
2. The Applicant agrees that when water and/or sewer facilities become available, the applicant or their successor in title will connect to the public water and/or sewer system.

\_\_\_\_\_  
PRINT NAME

\_\_\_\_\_  
APPLICANTS SIGNATURE/DATE

Monroe Municipal Utilities Authority

\_\_\_\_\_  
AUTHORIZED SIGNATURE